

JVC

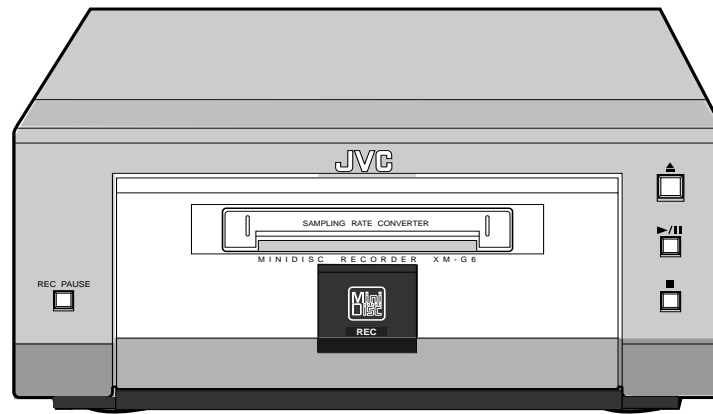

MINIDISC RECORDER ENREGISTREUR MINIDISC

XM-G6



INSTRUCTIONS MANUEL D'INSTRUCTIONS

For Customer Use:

Enter below the Model No. and Serial No. which are located either on the rear, bottom or side of the cabinet. Retain this information for future reference.

Model No. _____



Serial No. _____

LVT0378-001A

[J]

Warnings, Cautions and Others

Mises en garde, précautions et indications diverses

	CAUTION RISK OF ELECTRIC SHOCK DO NOT OPEN	
CAUTION: TO REDUCE THE RISK OF ELECTRIC SHOCK. DO NOT REMOVE COVER (OR BACK) NO USER SERVICEABLE PARTS INSIDE. REFER SERVICING TO QUALIFIED SERVICE PERSONNEL.		

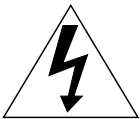

The lightning flash with arrowhead symbol, within an equilateral triangle is intended to alert the user to the presence of uninsulated "dangerous voltage" within the product's enclosure that may be of sufficient magnitude to constitute a risk of electric shock to persons.



The exclamation point within an equilateral triangle is intended to alert the user to the presence of important operating and maintenance (servicing) instructions in the literature accompanying the appliance.

For U.S.A.

This equipment has been tested and found to comply with the limits for a Class B digital device, pursuant to part 15 of the FCC Rules. These limits are designed to provide reasonable protection against harmful interference in a residential installation.

This equipment generates, uses and can radiate radio frequency energy and, if not installed and used in accordance with the instructions, may cause harmful interference to radio communications. However, there is no guarantee that interference will not occur in a particular installation. If this equipment does cause harmful interference to radio or television reception, which can be determined by turning the equipment off and on, the user is encouraged to try to correct the interference by one or more of the following measures:

Reorient or relocate the receiving antenna.

Increase the separation between the equipment and receiver.

Connect the equipment into an outlet on a circuit different from that to which the receiver is connected.

Consult the dealer or an experienced radio/TV technician for help.

WARNING: TO REDUCE THE RISK OF FIRE OR ELECTRIC SHOCK, DO NOT EXPOSE THIS APPLIANCE TO RAIN OR MOISTURE.

CAUTION

To reduce the risk of electrical shocks, fire, etc.:

1. Do not remove screws, covers or cabinet.
2. Do not expose this appliance to rain or moisture.

ATTENTION

Afin d'éviter tout risque d'électrocution, d'incendie, etc.:

1. Ne pas enlever les vis ni les panneaux et ne pas ouvrir le coffret de l'appareil.
2. Ne pas exposer l'appareil à la pluie ni à l'humidité.

For Canada/pour le Canada

CAUTION: TO PREVENT ELECTRIC SHOCK, MATCH WIDE BLADE OF PLUG TO WIDE SLOT, FULLY INSERT.

ATTENTION: POUR EVITER LES CHOCS ELECTRIQUES, INTRODUIRE LA LAME LA PLUS LARGE DE LA FICHE DANS LA BORNE CORRESPONDANTE DE LA PRISE ET POUSSER JUSQU'AU FOND.

For Canada/pour le Canada

THIS DIGITAL APPARATUS DOES NOT EXCEED THE CLASS B LIMITS FOR RADIO NOISE EMISSIONS FROM DIGITAL APPARATUS AS SET OUT IN THE INTERFERENCE-CAUSING EQUIPMENT STANDARD ENTITLED "DIGITAL APPARATUS," ICES-003 OF THE DEPARTMENT OF COMMUNICATIONS.

CET APPAREIL NUMERIQUE RESPECTE LES LIMITES DE BRUITS RADIOELECTRIQUES APPLICABLES AUX APPAREILS NUMIRIQUES DE CLASSE B PRESCRITES DANS LA NORME SUR LE MATERIEL BROUILLEUR: "APPAREILS NUMERIQUES", NMB-003 EDICTEE PAR LE MINISTRE DES COMMUNICATIONS.

IMPORTANT FOR LASER PRODUCTS/ IMPORTANT POUR LES PRODUITS LASER

① CLASSIFICATION LABEL, PLACED ON REAR ENCLOSURE

① ETIQUETTE DE CLASSIFICATION, PLACÉE A L'ARRIÈRE DU COFFRET

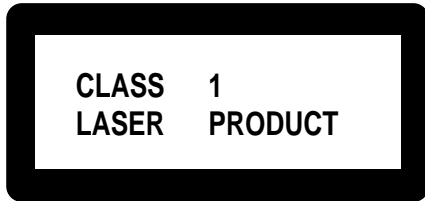

② WARNING LABEL, PLACED INSIDE THE UNIT

② ETIQUETTE D'AVERTISSEMENT PLACÉE À L'INTERIEUR DE L'APPAREIL



1. CLASS 1 LASER PRODUCT
2. **DANGER:** Invisible laser radiation when open and interlock failed or defeated. Avoid direct exposure to beam.
3. **CAUTION:** Do not open the top cover. There are no user serviceable parts inside the Unit; leave all servicing to qualified service personnel.

1. PRODUIT LASER CLASSE 1
2. **ATTENTION:** Radiation laser invisible quand l'appareil est ouvert ou que le verrouillage est en panne ou désactivé. Eviter une exposition directe au rayon.
3. **ATTENTION:** Ne pas ouvrir le couvercle du dessus. Il n'y a aucune pièce utilisable à l'intérieur. Laisser à un personnel qualifié le soin de réparer votre appareil.

Caution: Proper Ventilation

To avoid risk of electric shock and fire, and to prevent damage, locate the apparatus as follows:

1 Front:

No obstructions and open spacing.

2 Sides/ Top/ Back:

No obstructions should be placed in the areas shown by the dimensions below.

3 Bottom:

Place on the level surface. Maintain an adequate air path for ventilation by placing on a stand with a height of 10 cm (3 15/16 in.) or more.

Attention: Aération correcte

Pour prévenir tout risque de décharge électrique ou d'incendie et éviter toute détérioration, installez l'appareil de la manière suivante:

1 Avant:

Bien dégagé de tout objet.

2 Côtés/dessus/dessous:

Assurez-vous que rien ne bloque les espaces indiqués sur le schéma ci-dessous.

3 Dessous:

Posez l'appareil sur une surface plane et horizontale. Veillez à ce que sa ventilation correcte puisse se faire en le plaçant sur un support d'au moins dix centimètres (3 15/16 po.) de hauteur.

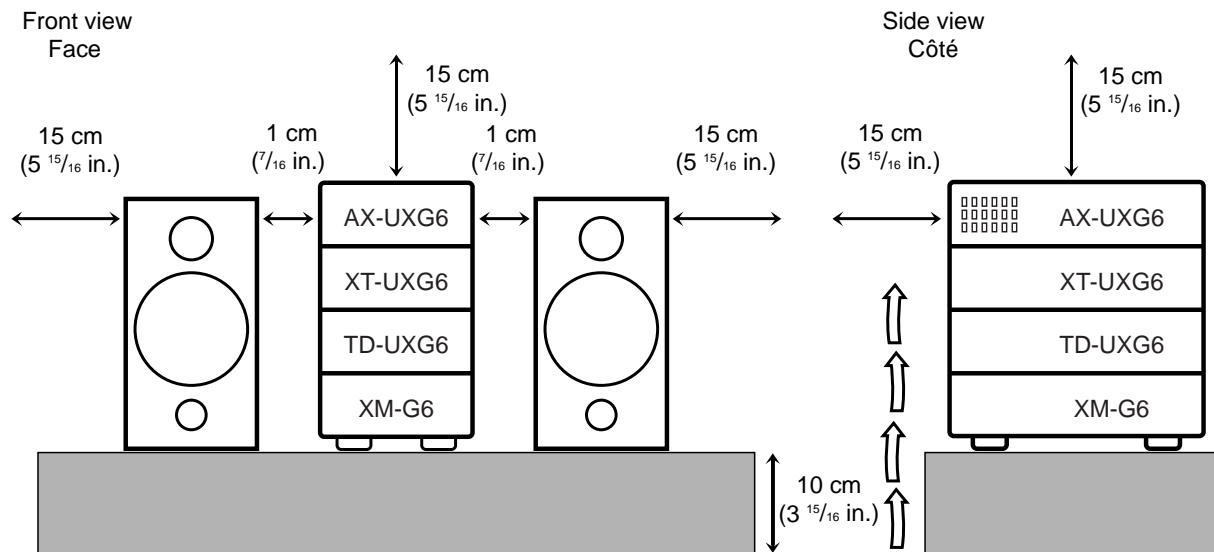

HOW TO LOCATE YOUR JVC SERVICE CENTER

TOLL FREE : 1-800-537-5722

<http://www.jvcservice.com>

Dear customer:

In order to receive the most satisfaction from your purchase, read the instruction booklet before operating the unit. In the event that repair is necessary, or for the address nearest your location, please refer to the factory service center list below or within the Continental United States, Call 1-800-537-5722 for your authorized servicer. Remember to retain your Bill of Sale for Warranty Service.

—JVC

JVC SERVICE & ENGINEERING COMPANY OF AMERICA DIVISION OF JVC AMERICAS CORP.

FACTORY SERVICE CENTER LOCATIONS

10 New Maple Avenue
Pine Brook, NJ 07058-9641
(973) 396-1000

1500 Lakes Parkway
Lawrenceville, GA 30243-5857
(770) 339-2582

705 Enterprise Street
Aurora, IL 60504-8149
(630) 851-7855

5665 Corporate Avenue
Cypress, CA 90630-0024
(714) 229-8011

2969 Mapunapuna Place
Honolulu, HI 96819-2040
(808) 833-5828

10700 Hammerly, Suite 110
Houston, TX 77043
(713) 935-9331

13 Cummings Park
Woburn, MA 01801
(781) 376-9100

8192 State Road 84
Davie, FL 33324
(954) 472-1960

890 Dubuque Avenue
South San Francisco, CA 94080-1804
(650) 871-2666

Sophisticated electronic products may require occasional service. Just as quality is a keyword in the engineering and production of the wide array of JVC products, service is the key to maintaining the high level of performance for which JVC is world famous. The JVC service and engineering organization stands behind our products.

NATIONAL HEADQUARTERS
JVC SERVICE & ENGINEERING COMPANY OF AMERICA
DIVISION OF JVC AMERICAS CORP.
1700 Valley Road
Wayne, NJ 07470

If you ship the product •••

Pack your JVC unit in the original carton or one of equivalent size and strength. Enclose, with the unit, a letter stating the problem or symptom that exists and also a copy of the receipt or bill of sale you received when you purchased your JVC unit. Print your home return address on the outside and the inside of the carton. Send to the appropriate JVC Factory Service Center as listed above.

Don't service it yourself.

CAUTION

To prevent electrical shock, do not open the cabinet. No user serviceable parts inside.
Refer servicing to qualified service personnel.

ACCESSORIES

To purchase accessories for your JVC product, you may contact your local JVC Dealer.
Or from the 48 Continental United States call toll free : 800-882-2345



LIMITED WARRANTY AUDIO-1

JVC COMPANY OF AMERICA warrants this product and all parts thereof, except as set forth below ONLY TO THE ORIGINAL PURCHASER AT RETAIL to be FREE FROM DEFECTIVE MATERIAL AND WORKMANSHIP from the date of original retail purchase for the period as shown below. ("The Warranty Period.")

PARTS	LABOR
1YR	1YR

THIS LIMITED WARRANTY IS VALID ONLY IN THE FIFTY(50) UNITED STATES, THE DISTRICT OF COLUMBIA AND IN COMMONWEALTH OF PUERTO RICO.

WHAT WE WILL DO:

If this product is found to be defective, JVC will repair or replace defective parts at no charge to the original owner. Such repair and replacement services shall be rendered by JVC during normal business hours at JVC authorized service centers. Parts used for replacement are warranted only for the remainder of the Warranty Period. All products and parts thereof may be brought to a JVC authorized service center on a carry-in basis except for Television sets having a screen size 25 inches and above which are covered on an in-home basis.

WHAT YOU MUST DO FOR WARRANTY SERVICE:

Return your product to a JVC authorized service center with a copy of your bill of sale. For your nearest JVC authorized service center, please call toll free: (800)537-5722. If service is not available locally, box the product carefully, preferably in the original carton, and ship, insured, with a copy of your bill of sale plus and letter of explanation of the problem to the nearest JVC Factory Service Center, the name and location of which will be given to you by the toll-free number. If you have any questions concerning your JVC Product, please contact our Customer Relations Department.

WHAT IS NOT COVERED:

- This limited warranty provided by JVC **does not cover:**
1. Products which have been subject to abuse, accident, alteration, modification, tampering, negligence, misuse, faulty installation, lack of reasonable care, or if repaired or serviced by anyone other than a service facility authorized by JVC to render such service, or if affixed to any attachment not provided with the products, or if the model number or serial number has been altered, tampered with, defaced or removed;
 2. Initial installation and installation and removal for repair;
 3. Operational adjustments covered in the Owner's Manual, normal maintenance, video and audio head cleaning;
 4. Damage that occurs in shipment, due to act of God, and cosmetic damage;
 5. Signal reception problems and failures due to line power surge;
 6. Video Pick-up Tubes/CCD Image Sensor, Cartridge, Stylus(Needle) are covered for 90 days from the date of purchase;
 7. Accessories;
 8. Batteries (except the Rechargeable Batteries are covered for 90 days from the date of purchase);

There are no express warranties except as listed above.

THE DURATION OF ANY IMPLIED WARRANTIES, INCLUDING THE IMPLIED WARRANTY OF MERCHANTABILITY, IS LIMITED TO THE DURATION OF THE EXPRESS WARRANTY HEREIN.

JVC SHALL NOT BE LIABLE FOR THE LOSS OF USE OF THE PRODUCT, INCONVENIENCE, LOSS OR ANY OTHER DAMAGES, WHETHER DIRECT, INCIDENTAL OR CONSEQUENTIAL (INCLUDING, WITHOUT LIMITATION, DAMAGE TO TAPES, RECORDS OR DISCS) RESULTING FROM THE USE OF THIS PRODUCT, OR ARISING OUT OF ANY BREACH OF THIS WARRANTY. ALL EXPRESS AND IMPLIED WARRANTIES, INCLUDING THE WARRANTIES OF MERCHANTABILITY AND FITNESS FOR PARTICULAR PURPOSE, ARE LIMITED TO THE WARRANTY PERIOD SET FORTH ABOVE.

Some states do not allow the exclusion of incidental or consequential damages or limitations on how long an implied warranty last, so these limitations or exclusions may not apply to you. This warranty gives you specific legal rights and you may also have other rights which vary from state to state.

JVC COMPANY OF AMERICA
DIVISION OF JVC AMERICAS CORP.

1700 Valley Road
Wayne, NJ 07470

REFURBISHED PRODUCTS CARRY A SEPARATE WARRANTY, THIS WARRANTY DOES NOT APPLY. FOR DETAILS OF REFURBISHED PRODUCT WARRANTY, PLEASE REFER TO THE REFURBISHED PRODUCT WARRANTY INFORMATION PACKAGED WITH EACH REFURBISHED PRODUCT.

For customer use:

Enter below the Model No. and Serial No. which is located either on the rear, bottom or side of the cabinet. Retain this information for future reference.

Model No.: _____ Serial No.: _____

Purchase date: _____ Name of dealer: _____

Introduction

We would like to thank you for purchasing one of our JVC products. Before operating this unit, read this manual carefully and thoroughly to obtain the best possible performance from your unit, and retain this manual for future reference.

Welcome to XM-G6

XM-G6 is MiniDisc Recorder exclusively designed for FS-G6 compact component system. Although you cannot operate this MD recorder without FS-G6, this integration offers enhanced features to simple and easy operations systematized on FS-G6.

Since the basic settings and common operations are almost identical to those of FS-G6, this manual mainly explains MD related operations. Concerning FS-G6's settings and operations, refer to its Instructions for details.

- The following marks are used in this manual:



Gives you warnings and cautions to prevent from a damage or risk of fire/electric shock. Also gives you information which is not good for obtaining the best possible performance from the unit.



Gives you information and hints you had better know.

Precautions

Installation

- Install in a place which is level, dry and neither too hot nor too cold — between 5°C (41°F) and 35°C (95°F).
- Install the unit in a location with adequate ventilation to prevent internal heat built-up in the units.
- Leave sufficient distance between the unit and a TV.



DO NOT install the units in a location near heat sources, or in a place subject to direct sunlight, excessive dust or vibration.

Power sources

- The power source of this unit is controlled by FS-G6's system operation. Refer to its Instructions.
- When connecting the unit to the FS-G6, make sure to unplug the AC power cord of the FS-G6 from the wall outlet.

Moisture condensation

Moisture may condense inside the unit in the following cases:

- After starting heating in the room
 - In a damp room
 - If the unit is brought directly from a cold to a warm place
- Should this occur, the system may malfunction. In this case, leave the unit turned on for a few hours until the moisture evaporates, unplug the AC power cord, and then plug it in again.



DO NOT disassemble the unit since there are no user serviceable parts inside.

If anything goes wrong, unplug the AC power cord and consult your dealer.

Contents

Introduction	1	Handling MDs	27
Welcome to XM-G6	1	MD Handling Precautions	27
Precautions	1		
Contents	2	Additional Information	28
Location of the Buttons and Controls	3	MD Disc Types	28
Front Panels	4	ATRAC (Adaptive TRansform Acoustic Coding)	28
Remote Control (belongs to FS-G6)	4	UTOC (User Table Of Contents)	28
Getting Started	5	Serial Copy Management System (SCMS)	29
Unpacking	5	Sound Skip Guard Memory	29
Connecting the System Control Cable and the External Wire	5	MD Messages	30
Connecting Another Digital Audio Equipment	6	MD Restrictions	31
Playing Back an MD	7	Troubleshooting	32
Playing Back the Entire MD — Normal Play	7	Specifications	32
Searching and Skipping Tracks	8		
Programing the Playing Order of the Tracks — Program Play	9		
Playing at Random — Random Play	10		
Repeating Tracks — Repeat Play	10		
Recording onto an MD	11		
Things to Know Before You Start Recording	11		
Recording FM/AM Broadcasts	12		
Recording a CD	14		
Recording a Tape	15		
Recording onto a Tape	16		
Recording the External Equipment	17		
Editing an MD	19		
Introducing MD Editing Functions	19		
DIVIDE Function	20		
JOIN Function	21		
MOVE Function	22		
ERASE Function	22		
ALL ERASE Function	23		
Erasing a Portion of a Track	23		
Assigning Titles to an MD	24		
Assigning a Title	24		
Changing the Title	26		

Location of the Buttons and Controls

Become familiar with the buttons and controls on the unit.

XM-G6 MiniDisc Recorder

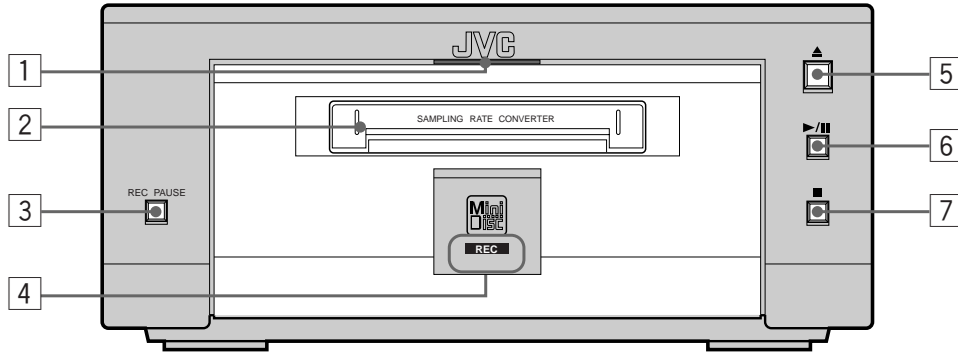

AX-UXG6 Stereo Amplifier (belongs to FS-G6)

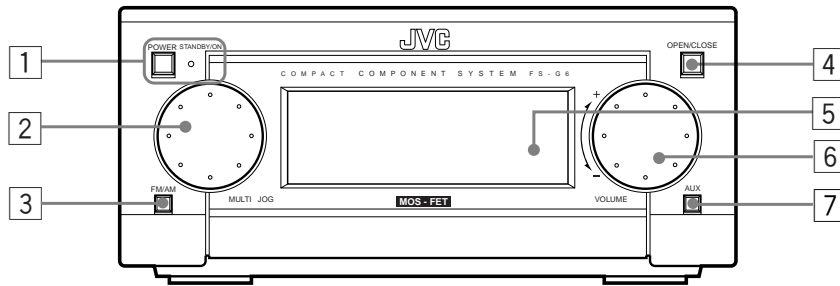

Buttons behind the Sliding Panel (When pressing OPEN/CLOSE button 4)

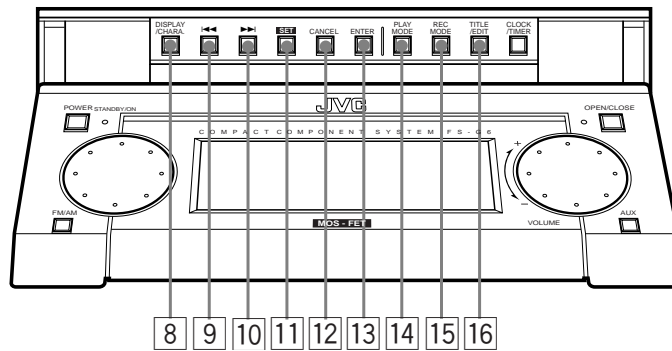

Front Panels

MiniDisc Recorder XM-G6

- 1 MD IN lamp (7)
- 2 MD loading slot (7)
- 3 REC PAUSE button (12)
- 4 REC indicator (12)
- 5 ▲ (eject) button (8)
- 6 ►/|| (play/pause) button (8)
- 7 ■ (stop) button (8)

Stereo Amplifier AX-UXG6

- 1 POWER button and STANDBY/ON lamp
- 2 MULTI JOG dial
- 3 FM/AM button (12)
- 4 OPEN/CLOSE button (7)
- 5 Display window
- 6 VOLUME dial
- 7 AUX button (17)

Buttons behind the Sliding Panel

- 8 DISPLAY/CHARA. button (13, 25)
- 9 ◀◀ button (8, 9, 25)
- 10 ▶▶ button (8, 9, 25)
- 11 SET button (9, 13, 20, 25)
- 12 CANCEL button (9, 21, 25)
- 13 ENTER button (21, 25)
- 14 PLAY MODE button (9)
- 15 REC MODE button (13)
- 16 TITLE/EDIT button (20, 24)

Remote Control (belongs to FS-G6)

* MD related operations are mainly assigned to the hollow buttons as illustrated below.

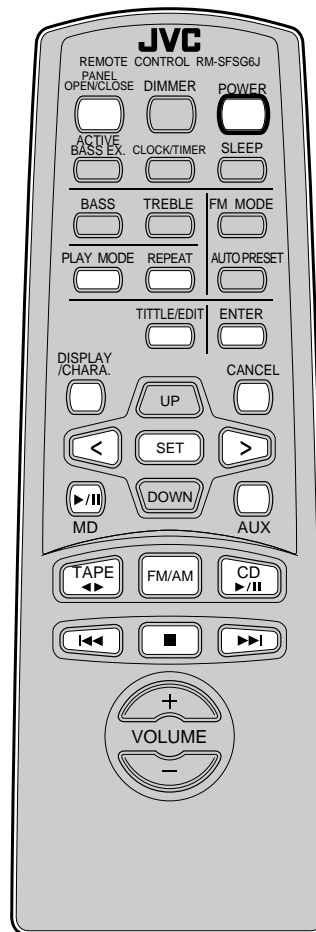

- You can also use the buttons on the remote control if they have the same or similar names (or marks) as those on the units.

If operation using the remote control is different from that using each unit, it is then explained.



Concerning with the remote control
Refer to the Instructions supplied with FS-G6.

Getting Started

Unpacking

After unpacking, check to be sure that you have the following items.

- Optical digital cable (1)
- External wire (1)

The number in the parentheses indicates the quantity of the pieces supplied. If any is missing, consult your dealer immediately.

Connecting the System Control Cable and the External Wire

Since XM-G6 Mini Disc Recorder is exclusively designed for FS-G6 compact component system, you can easily connect this unit using the system control cable and connector equipped on the rear panel of each unit as illustrated.

- To prevent malfunction, connect the external wire as illustrated.

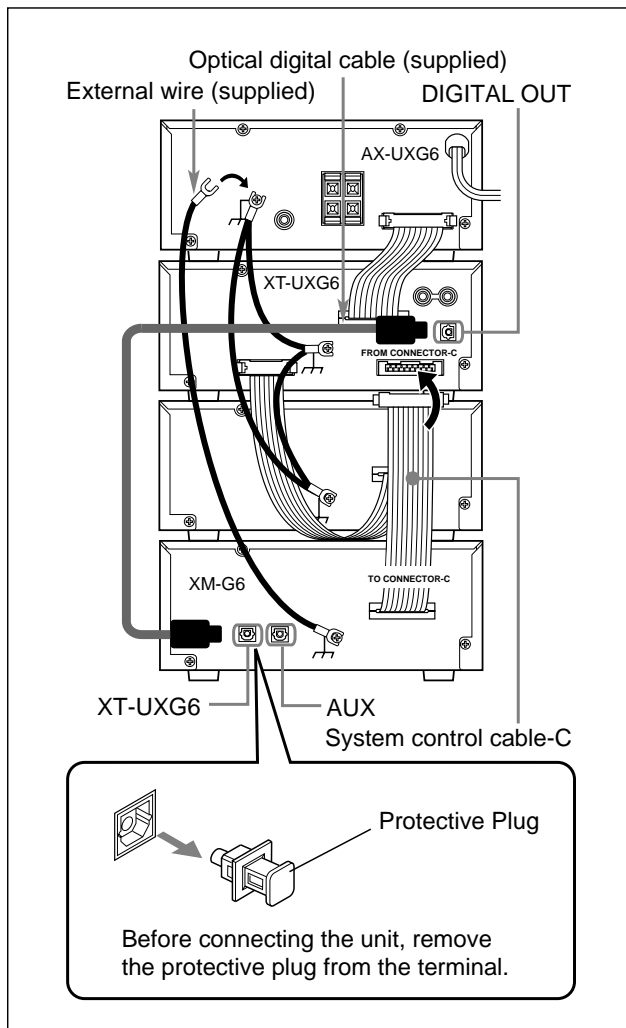

When connecting the XM-G6 MD recorder
Make sure to turn off FS-G6 and unplug the AC power cord. Leave it until all the connections complete.



DO NOT place XM-G6 unit or any other equipment onto AX-UXG6 stereo amplifier unit.
Damage or malfunction may result from heat generating portion of AX-UXG6.

- 1 Turn off FS-G6 system and unplug the AC power cord from the wall outlet.**
- 2 Place the FS-G6's units onto the XM-G6 unit.**
For example as follows, from top to bottom: AX-UXG6, XT-UXG6, TD-UXG6, finally XM-G6.
- 3 Using the system control cable-C, connect XM-G6 unit to XT-UXG6 unit.**



When connecting the system control cable to the connector

Make sure to connect the cable to the terminal having the same name as "FROM CONNECTOR-C" and "TO CONNECTOR-C."

- To connect the system control cable, press the middle of the connector body until it clicks into the terminal on the rear panel.
- To disconnect, pull the connector out pushing both sides of the connector body. Never pull out the cables themselves.

To connect

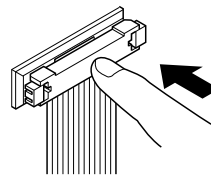

To disconnect

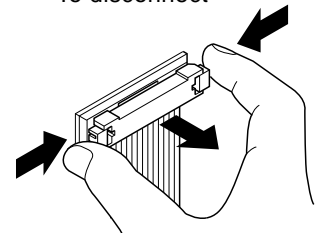

- 4 Using the Optical digital cable, connect between XM-G6 unit and XT-UXG6 unit.**

Now you have finished installation of XM-G6 unit to FS-G6 system.

Connecting Another Digital Audio Equipment

For digital audio recording onto an MD, XM-G6 unit connected to FS-G6 system has one more optical digital terminal (OPTICAL DIGITAL IN for AUX), prepared for an external digital audio output equipment.

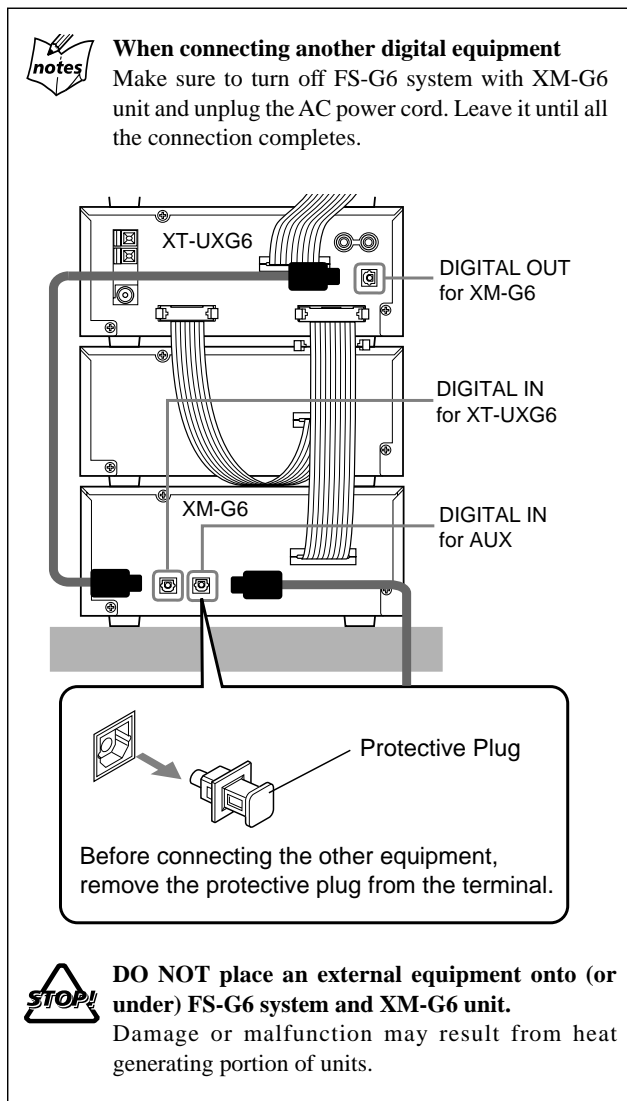

- 1** Turn off FS-G6 system and unplug the AC power cord from the wall outlet.
- 2** Using the Optical digital cable (not supplied), connect between XT-UXG6 unit and another digital equipment.

Now you have finished installation to FS-G6 system.

Playing Back an MD

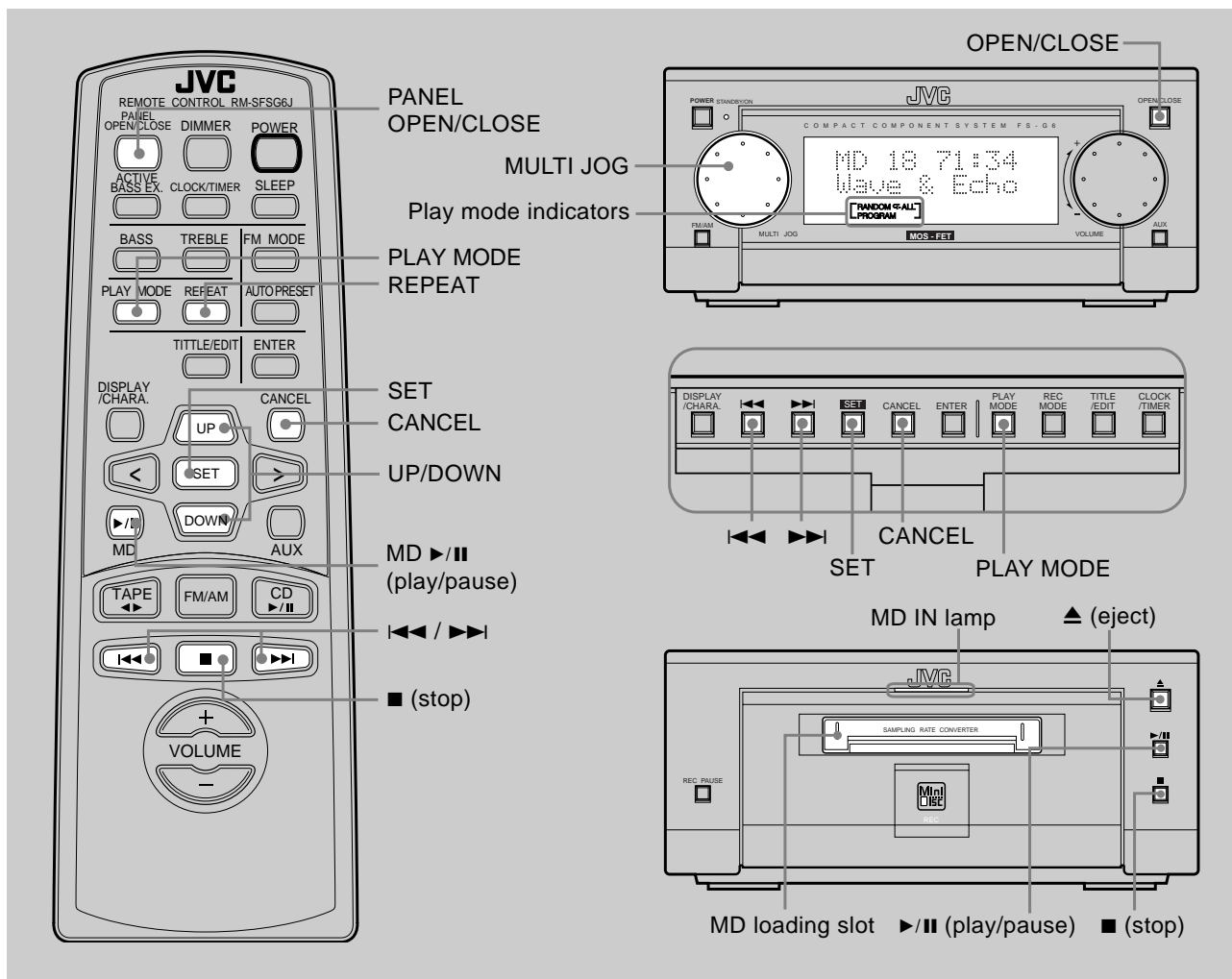

You can use Normal, Program, Random, or Repeat Play.

- When using the buttons behind the sliding panel, press OPEN/CLOSE button on AX-UXG6 unit to open the sliding panel first.
- When using the remote control, press MD ►/|| (play/pause) button first and ■ (stop) button successively.

Playing Back the Entire MD — Normal Play

1 Insert an MD into the MD loading slot.

The MD is pulled in automatically to light on the MD IN lamp orange.

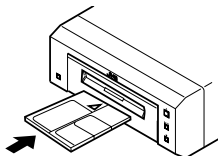

- Make sure to insert an MD in the direction of arrow mark on the MD cartridge.



If you cannot insert an MD

You have inserted an MD incorrectly and taken it off by force.

MD loading slot rejects MD insertion. If this occurs, wait for one minute at most with the MD recorder turned on until a mechanical sound comes out of the MD mechanism.

The following information appears in the display window of FS-G6 as follows:

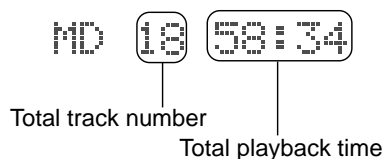

**If the MD or each track has a title**

The disc title and track titles will be shown at the lower portion of the display window (Title longer than 11 characters scrolls to show the entire title).



DO NOT insert any foreign matters.

2 Press ►/|| (play/pause) button on the MD recorder or MD ►/|| (play/pause) button on the remote control.

Each track of the MD starts playing back, and playback information appears in the display window as follows:

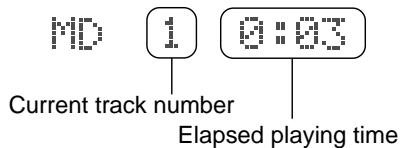

- **To stop playing back for a moment**, press ►/|| (play/pause) button on the MD recorder. The playback time starts blinking in the display window.

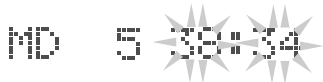

- **To resume playback**, press ►/|| (play/pause) button again. Playback continues from the point where it was stopped for a while.

3 Press ■ (stop) button to stop playing back the MD.

4 Press ▲ (eject) button on the MD recorder to remove the MD.

- Pressing ▲ (eject) button during playback directly, the MD recorder stops playback and ejects the MD.

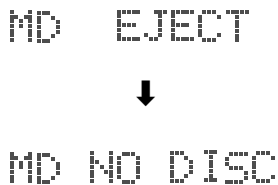

Searching and Skipping Tracks

While playing back an MD, you can do the following operations.

To search and skip to a particular point in a track

During playback, **press and hold** ◀◀ / ▶▶ button to meet the desired passages in a track:

- Press and hold ▶▶ button:
Fast forwards in the track.
- Press and hold ◀◀ button:
Fast reverses in the track.



UP/DOWN button on the remote control is also available to search and skip operations.

To go to another track

Before or during playback, **press** ◀◀ / ▶▶ button repeatedly:

- Press ▶▶ button:
Skips to the beginning of the next and succeeding tracks.
- Press ◀◀ button:
Goes back to the beginning of the current and previous tracks.



Rotating MULTI JOG dial clockwise also changes the tracks forwards quickly, while rotating it counterclockwise the tracks reverses quickly (</> button on the remote control also available).

Programming the Playing Order of the Tracks — Program Play

You can arrange the order in which the tracks play before you start playing. You can program up to 32 tracks.

1 Insert an MD.

- If the current playing source is not the MD, press ►/|| (play/pause) button on the MD recorder, then ■ (stop) button before going to the next step.

2 Press PLAY MODE button repeatedly until “MD PROGRAM” appears in the display window.

MD PROGRAM

- Each time you press the button, playback mode indicators also change as follows:

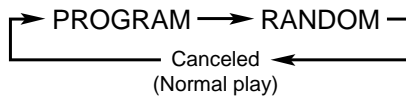

3 Rotate MULTI JOG dial to select a track number to be programmed (</> button also available).

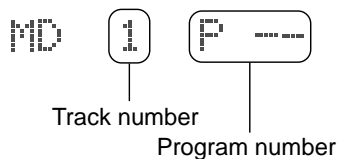

4 Press SET button to enter selected track number to be program-played.

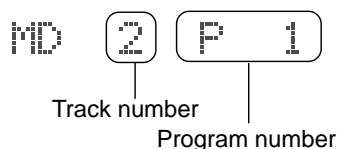

Here the track number 2 of the MD is stored into a program number 1, and shortly after that the total playback time of programmed tracks appears in the display window as follows:

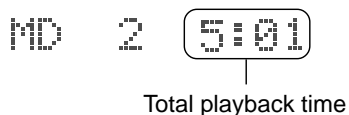

5 Repeat steps 3 to 4 to program other tracks you want up to 32 tracks.



- If you try to program a 33rd step “MEMORY FULL” will appear in the display window, and your entry is ignored.
- The total playback time of programmed tracks exceeds 99’59” “-- : --” will appear in the display window.

6 Press ►/|| (play/pause) button on the MD recorder. The programmed tracks are played back in the order you have set.

7 Press ■ (stop) button to quit Program play.

- When Program play finished, MD recorder automatically stops.

To check the program contents

Before playing back the MD, you can check the program contents by using ◀◀ / ▶▶ button.

Press ▶▶ button:

Shows the programmed tracks in the programmed order.

Press ◀◀ button:

Shows them in the reverse order.

To modify the program

Before playing back the MD, you can erase the last programmed track by pressing CANCEL button. Each time you press the button, the last programmed track is erased from the end of program.

- To add new tracks to the program before you start playing-back, simply select a track number again you want to add (repeat steps 3 to 4).

To erase all the programmed data

After playing back the MD, you can erase all the programmed track data by pressing ■ (stop) button. New program can be entered again.

To exit from Program play mode

Before or during playback, you can exit from Program play mode as follows:

- Before playback, press PLAY MODE button twice.
- During playback, press ■ (stop) button then PLAY MODE button twice.

Playback mode indicator goes off and the system resumes Normal play mode.



- Pressing ▲ (eject) button to eject the MD also quits Program play mode.

Playing at Random — Random Play

The tracks of the loaded MD will play in no special order (at random) when you select this mode.

1 Insert an MD.

If the current playing source is not the MD, press ►/|| (play/pause) button on the MD recorder, then ■ (stop) button before going to the next step.

2 Press PLAY MODE button repeatedly until “MD RANDOM” appears in the display window.

MD  RANDOM

- Each time you press the button, playback mode indicator also changes as follows:

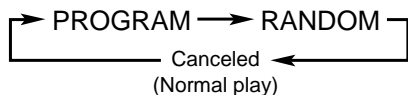

3 Press ►/|| (play/pause) button on the MD recorder.

MD  RANDOM

The track numbers are shuffled in the display window for a few seconds, and start playing back at random. Random play ends when all the tracks are played back once.

- Other MD operations are the same as Normal play.

4 Press ■ (stop) button to quit Random play.

To exit from Random play mode

During playing back the MD, you can exit from Random play mode as follows:

- Before playback, press PLAY MODE button once.
- During playback, press ■ (stop) button then press PLAY MODE button once.

Play mode indicator goes off and the system resumes Normal play mode.



Pressing ▲ (eject) button to eject the MD also quits Random play mode.

Repeating Tracks — Repeat Play

You can have the entire disc, the programmed tracks, or the individual track repeat as many times as you like.

1 Insert an MD.

If the current playing source is not the MD, press ►/|| (play/pause) button on the MD recorder, then ■ (stop) button before going to the next step.

2 Press REPEAT button on the remote control repeatedly to set the repeat play mode.

- Each time you press the button, repeat mode indicators light in the display window, and repeat playback mode changes as follows:

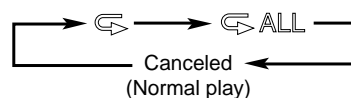



 : Repeats one track on the MD or in a program.

 ALL : Repeats all the tracks on the MD or a program.



3 Press ■ (stop) button to quit Repeat play.

To exit from Repeat play mode

Pressing REPEAT button repeatedly until repeat mode indicators ( and  ALL) goes off in the display window.



Combining play modes:

- When combining Program play and Repeat play, you can repeat whole the programmed tracks or one track among them ( and  ALL).
- When combining Random play and Repeat play, you can just repeat whole the shuffled tracks (only  ALL).

Recording onto an MD

Things to Know Before You Start Recording

- **It should be noted that it may be unlawful to pre-recorded tapes, records, or discs without the consent of the owner of copy right in the sound or video recording, broadcast or cable program and in any literary, dramatic, or artistic embodied therein.**
- The sampling frequency rate converter built in the MD recorder allows you to record a digital source if its sampling frequency is 32 kHz, 44.1 kHz, or 48 kHz. If no source equipment is connected to the AUX terminal or if the sampling frequency of the connected equipment is not 32 kHz, 44.1 kHz, or 48 kHz, "DIGITAL UNLOCK" appears in the display window (no recording is possible).
- When you record onto partially recorded MD, its contents are not erased or overwritten. The recording starts from the point following the last recorded track of the MD.
If you want to record on such an MD from the beginning, you have to erase its contents first (see "ALL ERASE Function" on page 23).
- The recording level is automatically set correctly, so it is not affected by the VOLUME dial. Thus, during recording you can adjust the sound you are actually listening to without affecting the recording level.

About the track marks

When playing an MD, you can move among the tracks using MULTI JOG dial or < / > button quickly, and ◀▶ / ▶▶ or UP/DOWN button step by step.

You can do this because there is a mark recorded at the beginning of each track enabling you to locate the track. This mark is called a "track mark" and the portion between two adjacent track marks is called a "track."

- **When recording from a digital source such as a CD player,** a track mark is recorded automatically at the beginning of each track.
- **When recording from an analog source such as FM/AM broadcasts,** no track mark is recorded on the MD. This means that, when playing this MD, the MD recorder will regard the entire recording as one track (track 1). You will not be able to select directly a certain portion or navigate through them. However, if there is a blank of three seconds or more, the MD recorder will consider it as a blank separating 2 tracks and consequently put a track mark.

To put a track mark manually while recording an analog source, press SET button where you want to put a track mark.

To add a track mark after recording is over, you can use the DIVIDE function (see page 20).

To avoid erasing important recordings

Recordable MDs have an erasure protect tab so that important recordings are not accidentally erased. When you finish recording or editing, slide open the erasure protect tab on the cartridge side surface. New recording or editing is now no longer possible.

To do re-recording or editing, return the tab to the closed position.

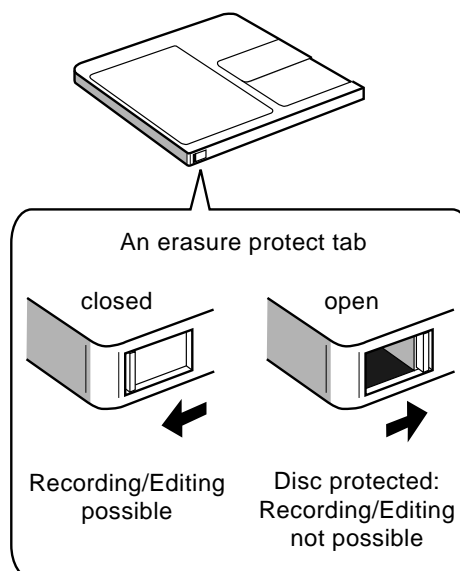

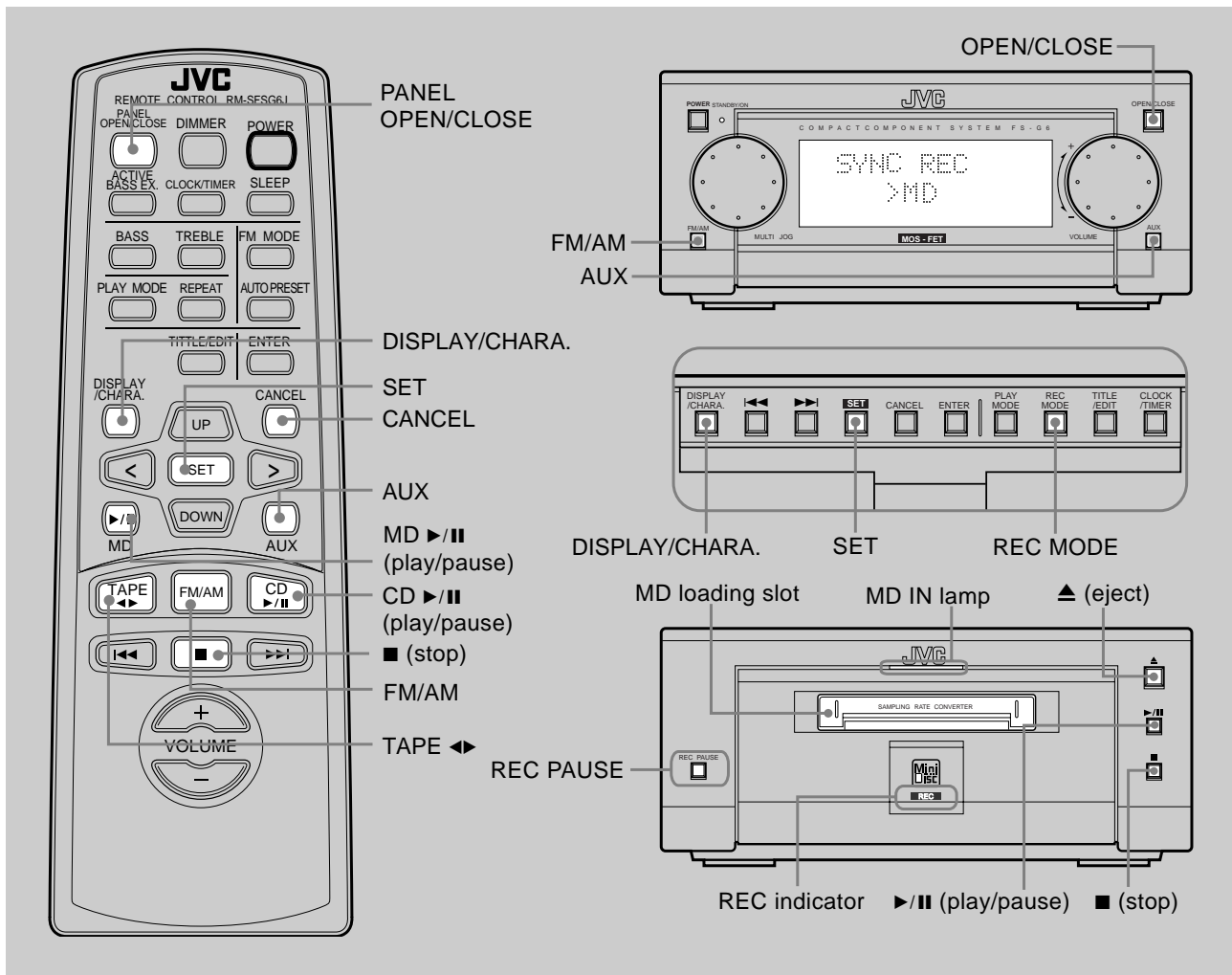

XM-G6 allows you to record a variety of audio sources onto an MD using either manual recording or synchronized recording.

- When using the buttons behind the sliding panel, press OPEN/CLOSE button on AX-UXG6 to open the sliding panel first.
- When using the remote control, press MD ▶/|| (play/pause) button first and ■ (stop) button successively.

Recording FM/AM Broadcasts

- 1 Insert a recordable MD with the arrow sign facing toward the MD loading slot.**

The MD IN lamp lights orange and MD information appears in the display window — total track number and total playback time.

- If you insert a blank MD, “BLANK DISC” appears.

- 2 Press FM/AM button.**

- 3 Tune into a desired station using MULTI JOG dial or ◀◀/ ▶▶ button.**

Refer to FS-G6's Instructions for details (pages 14 – 15).

- 4 Press REC PAUSE button on the MD recorder.**

The REC indicator on the MD recorder lights red. Information in the display window changes as follows:

```

FM 87.5 MHz
MD  -- 70:02
  
```

Remaining time for recording

5 Press ►/|| (play/pause) button on the MD recorder to start recording.

The REC indicator remains lit, and recording starts.

- **To stop recording temporarily**, press REC PAUSE button or ►/|| (play/pause) button on the MD recorder or MD ►/|| (play/pause) button on the remote control.
- **To resume recording**, press ►/|| (play/pause) button on the MD recorder or MD ►/|| (play/pause) button on the remote control again.

6 Press ■ (stop) button to stop recording as required.

Information in the display window changes as follows:

WRITING

You can remove the MD by pressing ▲ (eject) button.



Using DISPLAY/CHARA. button while recording

Each time you press the button, the display window switches between the remaining time and the elapsed time with the current track number alternately.



Track marking in Long Recording

Putting track marks manually while recording, you can easily identify and edit desired portions of the broadcast program.

To put a track mark, press SET button as required while recording and you can find out the current track number using DISPLAY/CHARA. button.

4 Press ■ (stop) button to stop recording as required.

“WRITING” appears in the display window, and you can remove the MD by pressing ▲ (eject) button.

Monophonic Long Recording

Using the REC MODE settings, you can record FM/AM broadcasts for twice as long as given recording time of the MD in monaural reception.

1 Repeat the steps 1, 2 and 3 in previous page.

2 Press REC MODE button to select a recording mode as follows:

MONO REC
>MD

3 Press SET button to start recording.

You can double the recording time length, and information appears in the display window as follows:

FM 87.5 MHz
MD -140:04

Remaining time for recording

- **To stop recording temporarily**, press REC PAUSE button or ►/|| (play/pause) button on the MD recorder or MD ►/|| (play/pause) button on the remote control.
- **To resume recording**, press ►/|| (play/pause) button on the MD recorder or MD ►/|| (play/pause) button on the remote control again.

Recording a CD

When recording a CD onto an MD, you can record the entire CD or the particular tracks manually and using the synchronized recording.

Recording a CD Manually

You can start recording an entire CD or any tracks of a CD while listening.

1 Insert a recordable MD into the MD loading slot.

The MD IN lamp lights orange.

2 Prepare a CD.

- Place a CD on the disc tray, press ►/|| (play/pause) button on the CD player or CD ►/|| (play/pause) on the remote control, then press ■ (stop) button before going to the next step.
- You can also record programmed tracks if you want (refer to FS-G6's Instructions, pages 17 to 18).

3 Press REC PAUSE button on the MD recorder.

The REC indicator on the MD recorder lights red.

4 Press ►/|| (play/pause) button on the CD player or CD ►/|| (play/pause) button on the remote control.

Recording starts automatically, and information changes in the display window as follows:

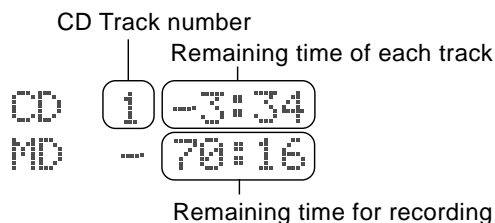

- To stop recording temporarily**, press REC PAUSE button or ►/|| (play/pause) button on the MD recorder or MD ►/|| (play/pause) button on the remote control.
- To resume recording**, press ►/|| (play/pause) button on the MD recorder or MD ►/|| (play/pause) button on the remote control again.

5 Press ■ (stop) button to stop recording as required. "WRITING" appears in the display window, and you can remove the MD by pressing ▲ (eject) button.

Recording a CD — Synchronized Recording

This is the easiest way of CD recording. Setting the recording mode, you can start playing back an entire CD and recording it onto an MD simultaneously.

1 Repeat the steps 1 and 2 in previous section.

2 Press REC MODE button behind the sliding panel to select "SYNC REC > MD."

Each time you press the button, the recording mode changes as follows:

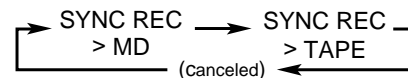

3 Press SET button to start recording.

Recording starts automatically, and information change in the display window as follows:

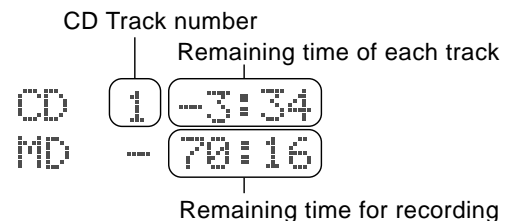

Each time you press DISPLAY/CHARA. button, information switches between the remaining time and elapsed time with the current track number alternately.



While synchronized recording

You cannot use pause function until the recording finishes.

4 Press ■ (stop) button (on either the CD player or the MD recorder) to quit recording as required.

"WRITING" appears in the display window, and you can remove the MD by pressing ▲ (eject) button.

- When all the tracks finished recording, CD player and MD recorder will automatically stop.



To record a single track during playback

Press REC MODE button to set "SYNC REC > MD" mode, you can record a current track during playback. The playback of the current track is stopped, and the same track starts playing back from the beginning again. At the same time, the MD recorder starts recording the current track.

- When the current track is recorded, both CD player and MD recorder automatically stop.

Recording a Tape

When recording from TD-UXG6 cassette deck, you can select one of the two recording methods — Manual Recording (stereo) and Sound Synchronized Recording.

- **Manual Recording** — Sound is recorded in stereo (both on the left and right audio channels). You have to operate the MD recorder and the cassette deck respectively.
- **Sound Synchronized Recording** — With this method, you can start recording when the sound signals come into the MD recorder (sound is recorded in stereo).

Sound Synchronized Recording will stop automatically if no sound comes in for more than 30 seconds.



If Sound Synchronized Recording will not work correctly

Use the Manual Recording. Sound Synchronized Recording starts automatically when the MD recorder detects sound signals come in. If sound signal is too weak for this unit to detect, Sound Synchronized Recording will not start (or will stop even while the source is being played).

- **To stop recording temporarily**, press REC PAUSE button or ►/|| (play/pause) button on the MD recorder or MD ►/|| (play/pause) button on the remote control.
- **To resume recording**, press ►/|| (play/pause) button on the MD recorder or MD ►/|| (play/pause) button on the remote control again.



Each time you press **DISPLAY/CHARA.** button, information switches between the remaining time for the recording and the elapsed time with the track number of the MD alternately.

6 Press ■ (stop) buttons both on the MD recorder and the cassette deck to quit recording as required.

“WRITING” appears in the display window, and you can remove the MD and the tape by pressing ▲ (eject) buttons.



Using ■ (stop) button on the remote control, you cannot stop both the MD recorder and the cassette deck. **Make sure to press each button on both units.**

Recording a Tape Manually

- 1 Insert a recordable MD into the MD loading slot.**
The MD IN lamp lights orange.
- 2 Prepare a tape playback.**
 - Place a tape on the tape tray, press ◀▶ (playback) button on the cassette deck or TAPE ◀▶ (playback) button on the remote control, then press ■ (stop) button before going to the next step.
- 3 Press REC PAUSE button on the MD recorder.**
The REC indicator on the MD recorder lights red, and the MD recorder switches to the recording-pause mode.
- 4 Press ►/|| (play/pause) button on the MD recorder or MD ►/|| (play/pause) button on the remote control.**
The MD recorder starts recording, and information changes in the display window and the remaining time for recording appears as follows:

```
TAPE
MD - 74:59
```

- 5 Press ◀▶ (playback) button on the cassette deck or TAPE ◀▶ (playback) button on the remote control in succession.**

Recording a Tape — Sound Synchronized Recording
Setting the recording mode, you can start playing back a tape and recording it onto an MD simultaneously.

- 1 Repeat the steps 1 and 2 in the previous section on this page.**
- 2 Press REC MODE button behind the sliding panel to select a recording mode as follows:**

```
SOUND SYNC
>MD
```

- 3 Press SET button.**
REC indicator on the MD recorder lights red, and information appears in the display window as follows:

```
TAPE
MD - 74:59
```

- 4 Press ◀▶ (playback) button on the cassette deck or TAPE ▶▶ (playback) button on the remote control.** Once the cassette deck starts playback, the MD recorder detects the audio signals and starts recording.



Each time you press DISPLAY/CHARA. button, information switches between the remaining time for the MD and the elapsed time for the MD alternately.

- If no sound comes in for more than 30 seconds, Sound Synchronized Recording will stop. "WRITING" appears in the display window, and you can remove the MD by pressing ▲ (eject) button.

Recording onto a Tape

You can record an MD onto a tape manually and using the recording mode feature.

- For details on recording operation of TD-UXG6 cassette deck, refer to FS-G6's Instructions (pages 22 – 24).

Recording an MD onto a tape manually

- 1 Insert an MD to be played-back into the loading slot, and load a recordable tape.**
The MD IN lamp lights orange.
- 2 Press ▶/|| (play/pause) button on the MD recorder or MD ▶/|| (play/pause) button on the remote control, then press ■ (stop) button immediately to prepare playing back the MD.**
- 3 Press REC PAUSE button on TD-UXG6 cassette deck to prepare for recording.**
- 4 Press ▶/|| (play/pause) button on the MD recorder or MD ▶/|| (play/pause) button on the remote control.**
The cassette deck automatically starts recording, and the information changes as follows:

Track number Elapsed playback time

MD 1 0:00

TAPE REC

- 5 Press ■ (stop) button (on either the MD recorder or the cassette deck) to quit recording as required.**
 - When all the tracks finished recording, MD recorder and the cassette deck will automatically stop.

Synchronized recording an MD onto a tape

- 1 Insert an MD to be played-back into the loading slot, and load a recordable tape.**
The MD IN lamp lights orange.
- 2 Press ▶/|| (play/pause) button on the MD recorder or MD ▶/|| (play/pause) button on the remote control, then press ■ (stop) button immediately to prepare playing back the MD.**
- 3 Press REC MODE button behind the sliding panel to select "SYNC REC>TAPE."**

SYNC REC
>TAPE

- 4 Press SET button to start recording.**
Recording the MD onto the tape starts, and information appears in the display window as follows:

Track number Elapsed playback time

MD 1 0:00

TAPE REC

- 5 Press ■ (stop) button (on either the MD recorder or the cassette deck) to quit recording as required.**
 - When all the tracks finished recording, MD recorder and the cassette deck will automatically stop.

Recording the External Equipment

When recording from the external equipment, you can select one of the two recording methods — Manual Recording and Sound Synchronized Recording.

- **Manual Recording** — Sound is recorded in stereo (both on the left and right audio channels). You have to operate the MD recorder and the external equipment respectively.
- **Sound Synchronized Recording** — With this method, you can start recording when the sound signals come into the MD recorder (sound is recorded in stereo). Sound Synchronized Recording will stop automatically if no sound comes in for more than 30 seconds.



If Sound Synchronized Recording will not work correctly

Use the Manual Recording. Sound Synchronized Recording starts automatically when the MD recorder detects sound signals come in. If sound signal is too weak for this unit to detect, Sound Synchronized Recording will not start (or will stop even while the source is being played).

5 Make the external equipment start playback in succession.

- **To stop recording temporarily**, press REC PAUSE button or ►/|| (play/pause) button on the MD recorder or MD ►/|| (play/pause) button on the remote control.
- **To resume recording**, press ►/|| (play/pause) button on the MD recorder or MD ►/|| (play/pause) button on the remote control again.



Each time you press DISPLAY/CHARA. button, information switches between the remaining time for the MD and the elapsed time for the MD alternately.

Recording the External Equipment Manually

First of all, make sure the proper cable connections between XM-G6 MD recorder and external equipment (see also page 6 in this manual, and refer to FS-G6's Instructions pages 9).

1 Insert a recordable MD.

The MD IN lamp lights orange.

2 Press AUX button to select either analog source or digital source according to the external equipment.

Each time you press AUX button, AUX mode changes between "AUX" and "AUX DIGITAL" alternately.

AUX ←→ AUX DIGITAL

3 Press REC PAUSE button on the MD recorder.

The REC indicator on the MD recorder lights red, and the MD recorder switches to the recording-pause mode.

4 Press ►/|| (play/pause) button on the MD recorder or MD ►/|| (play/pause) button on the remote control.

Selected source and remaining time for recording appear in the display window as follows:

```
AUX
MD  - 70:16
    or
AUX DIGITAL
MD  - 70:16
```

6 Press ■ (stop) button on the MD recorder to stop recording as required.

"WRITING" appears in the display window, and you can remove the MD by pressing ▲ (eject) button.

Recording the External Equipment — Sound Synchronized Recording

Setting the recording mode, you can start playing back the external equipment and recording from it onto an MD simultaneously.

First of all, make sure the proper cable connections between XM-G6 MD recorder and external equipment (see also page 6 in this manual, and refer to FS-G6's Instructions page 9).

1 Insert a recordable MD.

The MD IN lamp lights orange.

2 Press AUX button to select either analog source or digital source according to the external equipment.

Each time you press AUX button, AUX mode changes between "AUX" and "AUX DIGITAL" alternately.

AUX \longleftrightarrow AUX DIGITAL

3 Press REC MODE button to select recording mode as follows:

```
SOUND SYNC
>MD
```

4 Press SET button to start recording from the external equipment.

Selected source and remaining time for recording appear in the display window as follows:

```
AUX
MD - 70:16
or
```

```
AUX DIGITAL
MD - 70:16
```

- **To stop recording temporarily**, press REC PAUSE button or ►/|| (play/pause) button on the MD recorder or MD ►/|| (play/pause) button on the remote control.
- **To resume recording**, press ►/|| (play/pause) button on the MD recorder or MD ►/|| (play/pause) button on the remote control again.



Each time you press DISPLAY/CHARA. button, information switches between the remaining time for the MD and the elapsed time for the MD alternately.

- If no sound comes in for more than 30 seconds, Sound Synchronized Recording will stop. "WRITING" appears in the display window, and you can remove the MD by pressing ▲ (eject) button.

Editing an MD

Introducing MD Editing Functions

A recorded MD can be edited in many ways. The MD editing functions include dividing, joining, moving, erasing single tracks, erasing the entire disc, and more than one of them can be combined as required.

Dividing a track (DIVIDE) : Page 20

This function divides a track by adding a track marking(s) in the middle or where you want to search later.

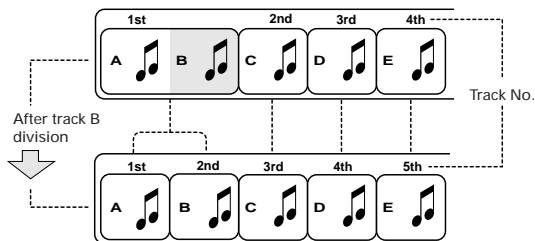

Joining a track (JOIN) : Page 21

This function joins two adjacent tracks into a single track by deleting a track marking.

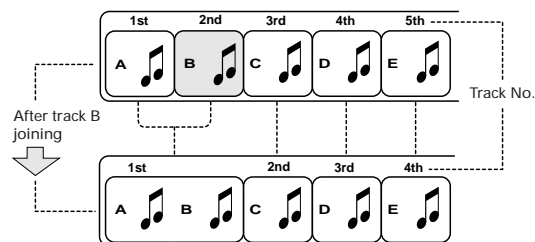

Moving a track (MOVE) : Page 22

This function moves a track by reordering the track numbers.

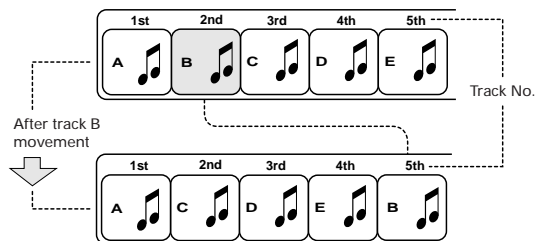

Erasing a track (ERASE) : Page 22

This function erases specified tracks. After the erasure, the subsequent tracks are justified and their track numbers are decremented automatically.

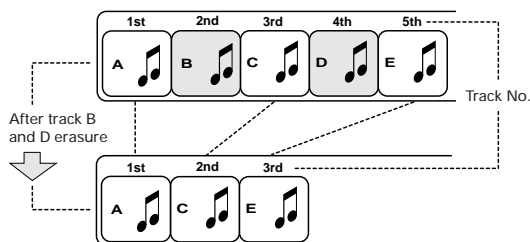

Erasing all tracks (ALL ERASE) : Page 23

This function erases data in a disc entirely.

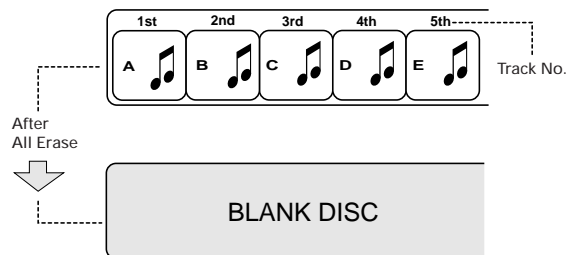

Erasing a Portion of a Track

By combining "DIVIDE," "ERASE," and "JOIN," for example, it is possible to erase only a part of an existing track.

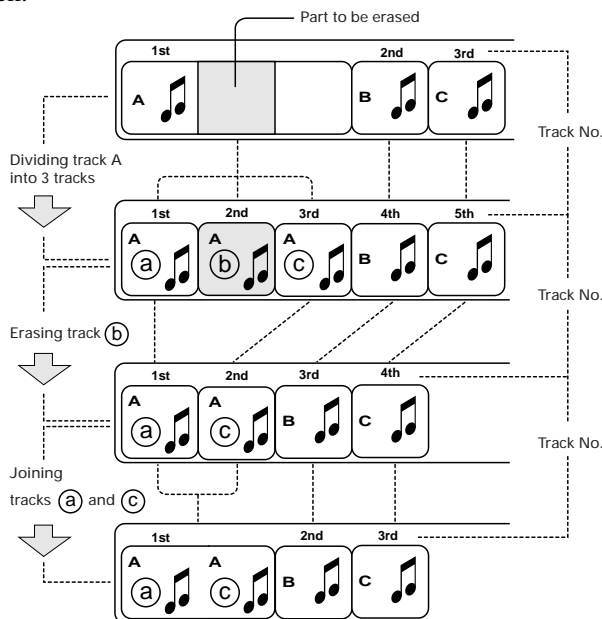

You can also assign titles to MDs and/or tracks (See page 24).

You can also assign titles to MDs and tracks (see page 24). A title can be assigned to a track or disc. Once a title is assigned, it is displayed in later playback for confirmation.

Each title can be composed of up to 64 characters (digits), and can be input using alphabetic characters (uppercase and lowercase), symbols and numerals.



If "PLAYBACK DISC" or "DISC PROTECTED" appears when you try to edit an MD

You cannot edit such MDs. See page 30.

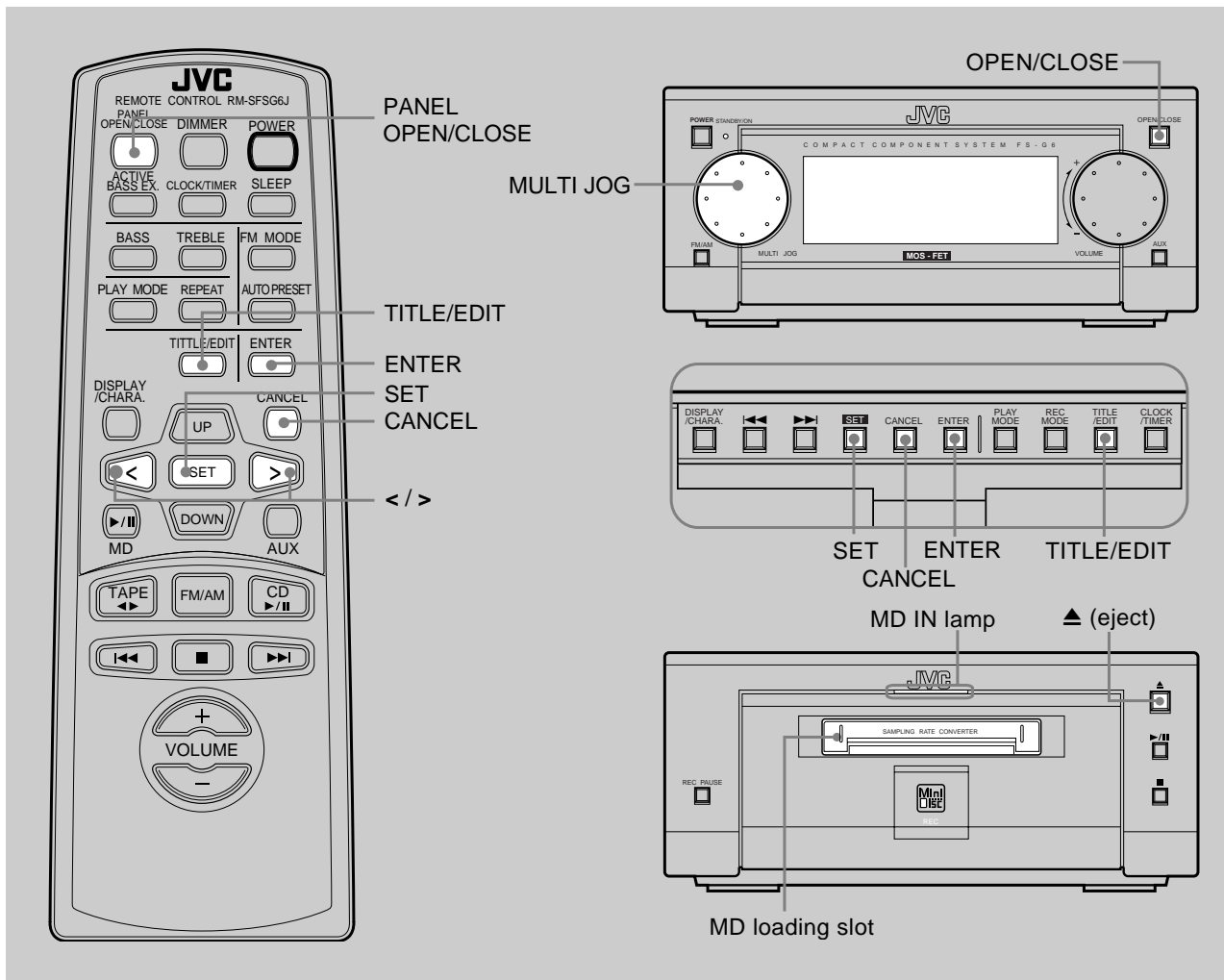

- To operate with the buttons behind the sliding panel, press OPEN/CLOSE button on AX-UXG6 to open the sliding panel first.
- To operate with the remote control, press MD ►/|| (play/pause) button first and ■ (stop) button successively.
- To quit operations any time during editing process, press TITLE/EDIT button repeatedly to resume normal operation mode.

DIVIDE Function

This function allows you to divide one track into two separate tracks. It is useful, for example, when you want to add track marks at a certain point within a track or if you want to separate a recording.

- 1 Insert an MD you want to edit into the MD loading slot.

The MD IN lamp lights orange.

- 2 Press TITLE/EDIT button until "DIVIDE?" appears in the display window.

DIVIDE ?

- 3 Press SET button.

The information of the first track of the MD appears in the display window, and playback starts.

MD 1 0:03

- 4 Rotate MULTI JOG dial or </> button on the remote control to select the track you want to divide.

MD 2 5:01

- If “TRACK PROTECTED” appears, the selected track has been write-protected by another component. You cannot edit such a protected track. To cancel the editing, press TITLE/EDIT button.

5 Press SET button when you find the point where you want to divide the track.

The MD recorder repeats the selected point — a portion of three seconds length following the dividing point.

```
POSITION
+ 0 OK?
```

- If you have selected a wrong track number, press CANCEL button then select the correct track.

6 Rotate MULTI JOG dial (</> button also available) to precisely adjust the dividing point.

- You can shift the dividing point up to ± 128 . This range (± 128) corresponds to approximately ± 8 seconds from the original point (Position 0).

```
POSITION
+ 15 OK?
```

When you stop rotating MULTI JOG dial, the system repeats the newly selected dividing point.

7 When you find the right position, press SET button. “PUSH ENTER” appears in the display window.

```
PUSH ENTER
```

8 Press ENTER button to finish the editing procedures.

- If you want to cancel the editing, press CANCEL button.

```
EDITING
```

9 Press \blacktriangle (eject) button to eject the MD.

“WRITING” appears while the editing you have made is being recorded onto the MD.

To join the divided tracks again, see the JOIN function.

JOIN Function

This function allows you to join two adjacent tracks into one track.

- To quit any time during editing process, press TITLE/EDIT button.

1 Insert an MD you want to edit into the MD loading slot.

The MD IN lamp lights orange.

2 Press TITLE/EDIT button until “JOIN?” appears in the display window.

```
JOIN ?
```

3 Press SET button.

```
JOIN
2+ 3 OK?
```

4 Rotate MULTI JOG dial to select the two adjacent tracks you want to join (</> button also available).

5 Press SET button.

```
PUSH ENTER
```

- If you have selected wrong tracks, press CANCEL button, then select the correct tracks by rotating MULTI JOG dial (</> button also available).
- If you want to cancel the editing, press TITLE/EDIT button.
- If “TRACK PROTECTED” appears, the selected track has been write-protected by another component. You cannot edit such a protected track. To cancel the editing, press TITLE/EDIT button.

6 Press ENTER button to finish the editing procedures.

```
EDITING
```

7 Press \blacktriangle (eject) button to eject the MD.

“WRITING” appears while the editing you have made is being recorded on the MD.

To divide the joined tracks, see the DIVIDE function.

MOVE Function

This function allows you to move a track to the position you prefer. It is useful to change the order of the tracks as you like.

- To quit any time during editing process, press TITLE/EDIT button.

1 Insert an MD you want to edit into the MD loading slot.

The MD IN lamp lights orange.

2 Press TITLE/EDIT button until "MOVE?" appears in the display window.

MOVE ?

3 Press SET button.

MOVE
-----+ 1 OK?

4 Rotate MULTI JOG dial to select the track you want to move (</> button also available).

5 Press SET button.

MOVE
-----+ 1 OK?

- If you have selected a wrong track number, press CANCEL button, then select the correct track number again.

6 Rotate MULTI JOG dial to select the position where you want to move the track (</> button also available).

7 Press SET button.

PUSH ENTER

- If you have selected wrong tracks, press CANCEL button, then select the correct tracks by rotating MULTI JOG dial (</> button also available).
- If you want to cancel the editing, press TITLE/EDIT button.

8 Press ENTER button to finish the editing procedures.

EDITING

9 Press \blacktriangle (eject) button to eject the MD.

"WRITING" appears while the editing you have made is being recorded on the MD.

ERASE Function

This function allows you to erase an unwanted track.

- To stop any time during editing process, press TITLE/EDIT button.

1 Insert an MD you want to edit into the MD loading slot.

The MD IN lamp lights orange.

2 Press TITLE/EDIT button until "ERASE?" appears in the display windows.

ERASE ?

3 Press SET button.

5 ERASE ?

4 Rotate MULTI JOG dial to select the track you want to erase (</> button also available).

5 Press SET button.

5 ERASE ?
5 -----

- If you have selected a wrong track number, press CANCEL button, then select the correct track number.
- If "TRACK PROTECTED" appears, the selected track has been write-protected by another component. You cannot edit such a protected track. To cancel the editing, press TITLE/EDIT button.

6 Repeat steps 4 and 5 if you want to erase more tracks (three tracks erasable at a time).

- 7** Press **ENTER** button to finish your selection of tracks to erase.

PUSH ENTER

- If you want to cancel the editing, press **CANCEL** button.

- 8** Press **ENTER** button again.

EDITING

- 9** Press **▲** (eject) button to eject the MD.
“WRITING” appears while the editing you have made is being recorded on the MD.

ALL ERASE Function

This function allows you to erase all the tracks on an MD.

- To stop any time during editing process, press **TITLE/EDIT** button.

- 1** Insert an MD you want to edit into the MD loading slot.
The MD IN lamp lights orange.

- 2** Press **TITLE/EDIT** button until “ALL ERASE?” appears in the display window.

ALL ERASE ?

- 3** Press **SET** button.

PUSH ENTER

- If you want to cancel the editing, press **CANCEL** button.
- If “TRACK PROTECTED” appears, the selected track has been write-protected by another component. You cannot edit such a protected track. To cancel the editing, press **TITLE/EDIT** button.

- 4** Press **ENTER** button to erase all the tracks.

EDITING



BLANK DISC

- 5** Press **▲** (eject) button to eject the MD.
“WRITING” appears while the editing you have made is being recorded on the MD.

Erasing a Portion of a Track

You can erase just a portion of one track by using the **DIVIDE**, **ERASE** and **JOIN** functions.

- To stop any time during editing process, press **TITLE/EDIT** button.

- 1** Insert an MD you want to edit into the MD loading slot.
The MD IN lamp lights orange.

- 2** Press **TITLE/EDIT** button repeatedly to select **DIVIDE** function.

- 3** Divide a track into 3 portions to isolate the portion to erase.

- Use the **DIVIDE** function by referring to page 20.

- 4** Erase the middle portion.

- Use the **ERASE** function by referring to page 22.

- 5** Join the two remaining portions.

- Use the **JOIN** function by referring to page 21.

Assigning Titles to an MD

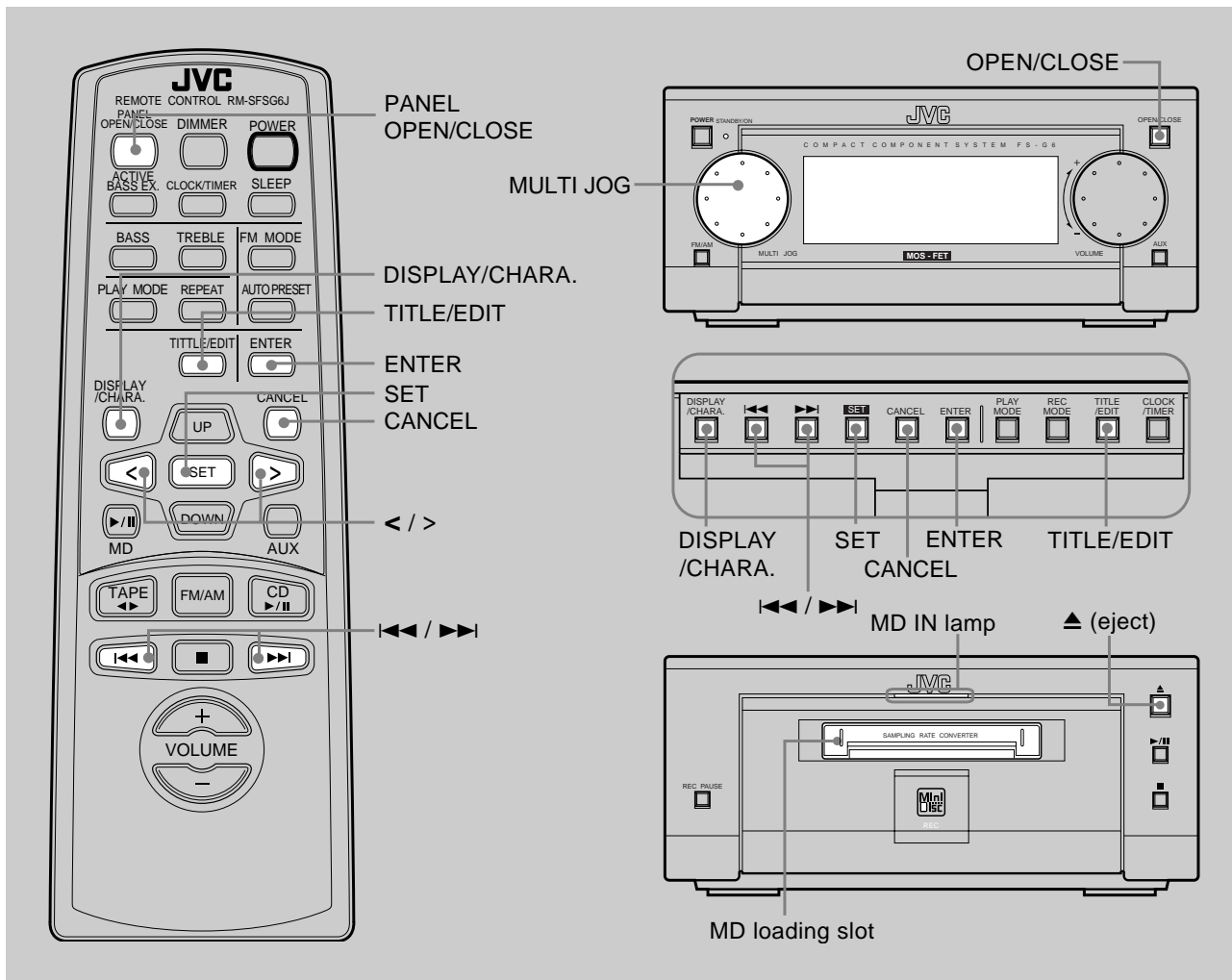

You can assign a name to each MD and to each track. Once a title is assigned, it is displayed in later playback for confirmation.

Each title can be composed of up to 64 characters, and can be input using alphabetic characters (uppercase and lowercase), symbols and numerals.

- To operate with the buttons behind the sliding panel, press OPEN/CLOSE button on AX-UXG6 to open the sliding panel first.
- To operate with the remote control, press MD ►/|| (play/pause) button first and ■ (stop) button successively.
- To quit operations any time during editing process, press TITLE/EDIT button repeatedly to resume normal operation mode.

Assigning a Title

- 1 Insert an MD you want to edit into the MD loading slot.

The MD IN lamp lights orange.

- 2 Press TITLE/EDIT button to enter title entry mode as follows:

- a) Pressing once makes track title entry available.

TITLE?

- b) Pressing twice makes disc title entry available, and go to step 4.

DISC TITLE?

3 Press SET button to select the track number.



Rotate MULTI JOG dial to select desired track number (or press < / > button on the remote control).

4 Press SET button again to enter the character entry mode.

The character sets present 11 characters alphabetically at a time in the upper portion of the display window.

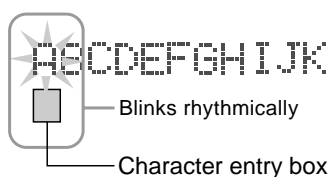

You can select a character from character sets in the upper portion of the display window, and enter it into the character entry box in the lower portion.

5 Press DISPLAY/CHARA. button repeatedly to select the character sets as follows:

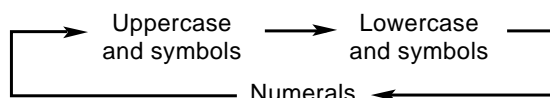

- See the character sets table on page 26 to know what characters, symbols, and numerals you can use.

6 Enter a character — an example to enter “F.”

- Rotate MULTI JOG dial (or press < / > button) to move the blinking box where a character you want exists.
- For example, select the character “F” from “ABCDEFGHIJK” on the upper portion then press SET button.
Selected character is entered into an entry box on the lower portion of the display window.

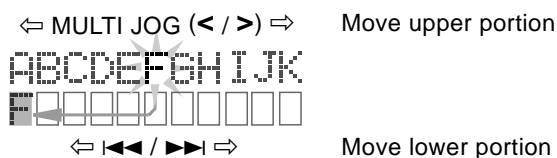

- To move the characters on the upper portion, rotate MULTI JOG dial or press < / > button on the remote control.
- To move the character entry box on the lower portion, press |<<< / >>>| button.

Each time you press SET button, the character entry box moves character by character. The display window can show just 11 characters at a time.

- If you enter the 12th character, the first character scrolls out to the left end.
- You can also scroll back to select and insert a new character using MULTI JOG dial and the similar controlling buttons.
- If you have entered an incorrect character, press CANCEL button to delete the last entry.
- To enter a blank, select a “(blank)” in the upper portion in the display window, then press SET button.

7 Repeat steps 5 and 6 to enter and edit other characters.

8 Press ENTER button to exit from title entry.

“PUSH ENTER” appears in the display window.

- If you want to cancel the editing, press TITLE/EDIT button after pressing ENTER button here.

9 Press ENTER button to fix desired characters.

- Pressing ▲ (eject) button, “WRITING” appears and the editing you have made is being recorded onto the MD.

You can assign titles during play or recording

• During play:

Entering a track title

The MD recorder repeats playback of the current track until you press ENTER button in step 8 above. When you press ENTER button, the next track will be played.

Entering a disc title

The MD recorder repeats playback of all tracks of the MD until you press ENTER button in step 8 above. When you press ENTER button, the MD recorder enters the track title entry mode.

• During recording:

Entering a track title

The MD recorder continues recording even after you press ENTER button in step 8 above. When you press ENTER button, a track title is assigned to the track where you have started the title entry.

- **During Synchronized Recording:**

You can assign the disc title, and 15 track titles one after another as recording goes on. The track titles you have entered are automatically assigned to the tracks recorded on the MD in sequential order. If you enter 16th track title or more, they are ignored.

Changing the Title

You can make a correction or change the title.

- 1 Follow steps 1 to 4 of pages 24 to 25.
- 2 Rotate MULTI JOG dial or press < / > button to select the character you want to correct.
 - Make sure that the character you want to change is blinking.
- 3 Press CANCEL button to delete the character you have selected in the step 2.
- 4 Enter the correct character.
 - a) Press DISPLAY/CHARA. button to select the character set you want.
 - b) Rotate MULTI JOG dial (or press < / > button) to select the correct character, then press SET button.
- 5 Repeat steps 2 to 4 to correct another characters.
- 6 Press ENTER button twice to finish correcting the title.
 - If you want to cancel the correction, press CANCEL button after pressing ENTER button once in this step.
- 7 Press ▲ (eject) button to eject the MD.

“WRITING” appears while the editing you have made is being recorded on the MD.



To erase all the characters

Press CANCEL button repeatedly in step 3 above to erase all the characters, then go to step 6.

Available Characters

Uppercase and Symbols

ABCDEFGHIJK

LMNOPQRSTUW

XYZ (blank) ! " # \$ % &

' () * + , - . / : ;

< = > ? @ _ `

Lowercase and Symbols

abcdefghijklmnop

qrstuvwxyz

xyz (blank) ! " # \$ % &

' () * + , - . / : ;

< = > ? @ _ `

Numerals

0123456789

Handling MDs

MD Handling Precautions

To maintain high quality audio for a long period

Since the disc is accommodated inside a cartridge, it can be handled easily without caring about dust and dirt. However, to maintain the high audio quality for an extended period, use care in the following points.

Installation location

Do not install the MD in following places.

- In a place subject to direct sunlight or where the temperature rises, for example in a closed automobile. The disc may be warped and unusable in these places.
- In a bathroom or where the humidity is high. The disc may be rusted in these places.
- On a beach or sandbox. The disc surface may be scratched or damaged if grit penetrates through an opening on the cartridge.

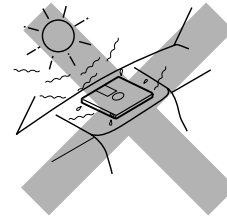

Periodical maintenance

When the cartridge gets dusty or dirty, wipe with a soft, dry cloth.

Do not open the shutter.

The shutter is usually locked to prevent opening. Do not force it open or the disc may be destroyed.

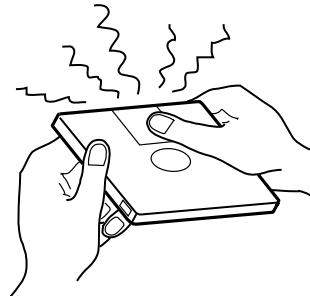

MD Disc Types

There are two types of MDs: Premastered (pre-recorded) and Recordable (blank).

Premastered MDs

Premastered MDs, which have been recorded at music studio, can be played back like regular CDs. On an MD of this type, data is recorded as the presence or absence of tiny pits. A laser beam focuses on the pits on the surface of the MD and reflects the detection back to the lens in the MD recorder. The MD recorder then decodes the signals and plays them back as music. This type of MD is called an “optical disc.”

Recordable MDs

Recordable MDs, which use magneto-optical technology, can be recorded and played back repeatedly. The laser inside the MD recorder applies heat to the MD, demagnetizing the magnetic layer of the MD for recording and playback. This type of MD is called “magnetic-optical disc.”



Premastered MD

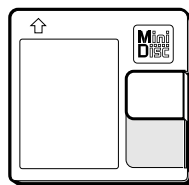

Recordable MD

ATRAC (Adaptive TRansform Acoustic Coding)

The MD provides 80 (max.) minutes recording and playback time, more than that of an audio CD, but in a diameter of only 64 mm. This ability to store such a large amount of data is the result of ATRAC, an audio compression technique developed for MD. This technology cuts out faint sounds that would not be heard by the human beings. This technology, based on human sensitivity to sounds, reduces recorded data volume up to about one-fifth of that of the original data.

UTOC (User Table Of Contents)

Found only on recordable MDs, this area contains sub-data (track number, recording data, etc.) which can be rewritten by the user.

UTOC enables us to search tracks quickly and edit tracks on the MD.

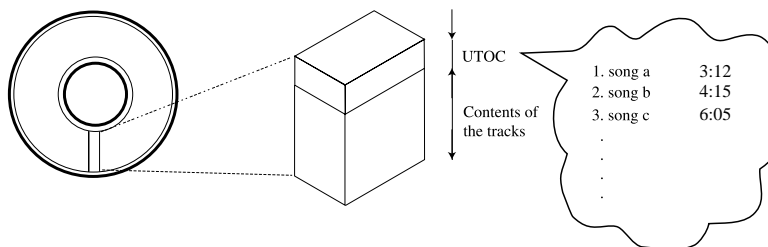

Serial Copy Management System (SCMS)

The MD recorder integrated to this unit uses the Serial Copy Management System which allows only first-generation digital copies to be made of premastered software (like CDs or prerecorded MDs).

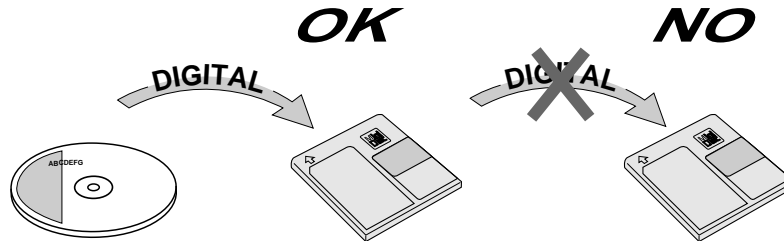

Sound Skip Guard Memory

The biggest weakness of discs is their susceptibility to vibration. The “Sound Skip Guard Memory” has been developed to cope with this weakness.

With this function, a few seconds of signals read by the optical read head from the disc are first stored in memory before being reproduced as audio signals. Thus, even when vibration or shock interrupts signals being read, these stored signals can continue to reproduce sounds for the few seconds. Thus, the user will enjoy uninterrupted music.

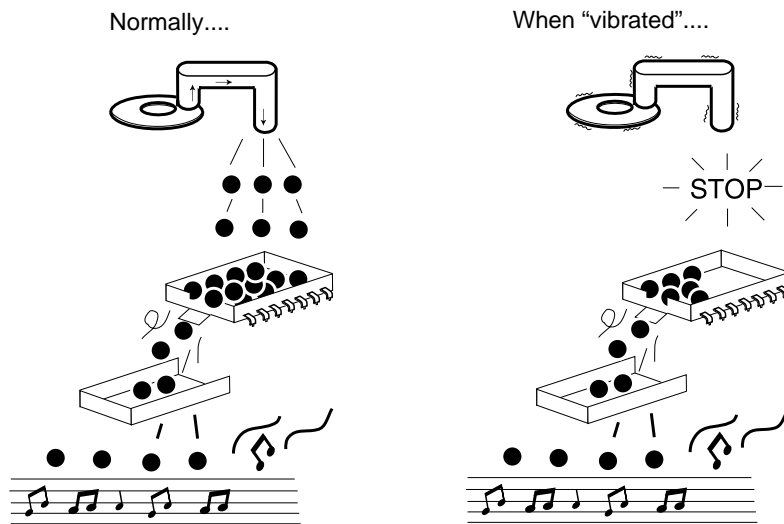

MD Messages

Message	Signification	Solution
BLANK DISC	The disc is blank.	Change the MD with another if you want to enjoy playback.
CANNOT JOIN	You are trying to join tracks which cannot be joined.	This is not a malfunction (see MD Restrictions on page 31).
DIGITAL IN UNLOCK	There is no digital device connected to the DIGITAL IN terminals.	Connect digital device using optical digital cable properly.
DISC ERROR	There is a problem with this MD.	Change the MD.
DISC FULL	There is no more space on the MD or there are over 254 tracks.	Use another recordable MD or erase some tracks.
DISC PROTECTED	The MD is write-protected.	Unprotect the MD or use another (see page 11).
EMERGENCY STOP	A malfunction has occurred during the recording.	Eject the MD and re-insert it.
LOAD ERROR	MD is not inserted correctly.	Insert the MD correctly.
MD NO DISC	There is no MD.	Put an MD.
NON-AUDIO CANNOT COPY	You are trying to copy a non-audio disc like a CD-ROM or a Video CD.	Stop recording.
PLAYBACK DISC	You are trying to edit or record on a playback-only MD.	Use a recordable MD.
SCMS CANNOT COPY	Digital copy of the 2nd generation is prohibited.	Use an analog recording method.
TRACK PROTECTED	A track has been protected against accidental erasure by other component than the MD recorder in use.	This protection cannot be released by this MD recorder. To stop editing, press TITLE/EDIT button.

MD Restrictions

The MD records data in an original format that differs from that of conventional cassette tapes or DATs. Since there are some limitations with this recording format, the following types of symptoms may occur. These symptoms are not malfunctions.

Symptoms	Cause
“DISC FULL” appears, even though there is still enough remaining time on an MD.	There is a maximum number of tracks which can be recorded, regardless of recording time. More than 254 tracks cannot be recorded on an MD.
“DISC FULL” appears even though the number of tracks and recording time do not reach the limit.	<ul style="list-style-type: none"> Repeating erasure and recording on the same MD creates many blank portions sparsely on the MD. When recording on such an MD, a track is recorded on these blank portions sparsely. If a track is divided and recorded into so many portions, “DISC FULL” appears.
The JOIN function sometimes does not work.	<ul style="list-style-type: none"> If a divided portion of less than 8 seconds is made while a track is recorded on the MD, that track cannot be joined to another track using the JOIN function. Furthermore, if that track is erased, the remaining time of the MD may not increase exactly by the erased amount.
The remaining time on the MD does not increase even when tracks are erased.	<ul style="list-style-type: none"> If a track has been divided into many portions while being recorded on the MD, sounds will drop out while fast forwarding or reversing such an MD.
The sound drops out during fast forward or fast rewind.	
The amount of recorded time on the MD added to the amount of remaining time is shorter than the MD’s total possible recording time.	You cannot record on a blank portion of less than 2 seconds in the MD. For this reason, the actual recording time of discs may become shorter.

Troubleshooting

If you are having a problem with your unit, check this list for a possible solution before calling for service. If you cannot solve the problem from the hints given here, or the unit has been physically damaged, call a qualified person, such as your dealer, for service.

Symptom	Possible Cause	Action
No sound is heard.	<ul style="list-style-type: none"> • Connections are incorrect, or loose. 	<ul style="list-style-type: none"> • Check all connections and make corrections (see pages 5 – 6).
Unable to record on an MD.	<ul style="list-style-type: none"> • You are using a prerecorded MD. • The MD is write-protected. 	<ul style="list-style-type: none"> • Change it with a recordable MD. • Unprotect the MD (see page 11).
Unable to operate the remote control.	<ul style="list-style-type: none"> • The path between the remote control and the remote sensor on the unit is blocked. • The batteries have lost their charge. 	<ul style="list-style-type: none"> • Remove the obstruction. • Replace the batteries.
Loaded MD cannot be ejected.	<ul style="list-style-type: none"> • The main AC power cord is not plugged in. 	<ul style="list-style-type: none"> • Plug in the AC power plug.
Operations are disabled.	<ul style="list-style-type: none"> • The built-in microprocessor has malfunctioned due to external electrical interference. 	<ul style="list-style-type: none"> • Unplug the unit then plug it back in.

Specifications

MD recorder

Audio Playing System: MiniDisc digital audio system

Recording System: Magneto-optical overwrite system

Reading System: Non-contact, semiconductor laser pickup ($\lambda=780$ nm)

Error Correction System: CIRC (Cross Interleave Reed-Solomon Code)

Sampling Frequency: 44.1 kHz (With sampling rate converter for recording — 32 kHz /44.1 kHz/48 kHz)

Audio Compression System: ATRAC (Adaptive TRansform Acoustic Coding)

Wow and Flutter: Immeasurable

Dimensions (approx.): 181 mm x 81 mm x 310 mm (W/H/D)
(7³/₁₆ in. x 3¹/₄ in. x 12¹/₄ in.)

Mass (approx.): 1.7 kg (3.5 lbs)

Supplied Accessories

See page 5.

Design and specifications are subject to change without notice.

US and foreign patents licensed from Dolby Laboratories Licensing Corporation.

