

HMC-NX5MD

SERVICE MANUAL

AEP Model
UK Model
E Model



HMC-NX5MD is the CD player and MD Deck section in DHC-NX5MD

CD Section	Model Name Using Similar Mechanism	NEW
	CD Mechanism Type	CDM53E-K4BD40
	Base Unit Name Type	BU-K4BD40
	Optical Pick-up Name	KSM-213DHAP/Z-NP
MD Section	Model Name Using Similar Mechanism	NEW
	MD Mechanism Type	MDM-7B
	Optical Pick-up Name	KMS-260B/J1N

SPECIFICATIONS

CD player section

System	Compact disc and digital audio system
Laser	Semiconductor laser ($\lambda=780$ nm) Emission duration: continuous
Laser output	Max. $44.6 \mu\text{W}^*$ *This output is the value measured at a distance of 200 mm from the objective lens surface on the Optical Pick-up Block with 7 mm aperture.
Wavelength	780 – 790 nm
Frequency response	20 Hz – 20 kHz (± 0.5 dB)
Signal-to-noise ratio	More than 90 dB
Dynamic range	More than 90 dB

MD deck section

System	MiniDisc digital audio system
Laser	Semiconductor laser ($\lambda=780$ nm) Emission duration: continuous
Laser output	Max. $44.6 \mu\text{W}^*$ *This output is the value measured at a distance of 200 mm from the objective lens surface on the Optical Pick-up Block with 7 mm aperture.
Sampling frequency	44.1 kHz
Frequency response	20 Hz – 20 kHz

General

Power requirements	
European models:	230 V AC, 50/60 Hz
Other models:	120 V, 220 V or 230 – 240 V AC, 50/60 Hz Adjustable with voltage selector
Power consumption	
European models:	190 watts
Other models:	220 watts
Dimensions (w/h/d)	Approx. 225 × 202 × 356 mm
Mass	Approx. 4.3 kg
Supplied accessories:	AM loop aerial (1) Remote Commander (1) Batteries (2) FM lead aerial (1) Speaker cords (2) Front speaker pads (8)

Design and specifications are subject to change without notice.

MINI Hi-Fi COMPONENT SYSTEM

SONY®

SELF-DIAGNOSIS FUNCTION

The self-diagnosis function consists of error codes for customers which are displayed automatically when errors occur, and error codes which show the error history in the test mode during servicing. For details on how to view error codes for the customer, refer to the following box in the instruction manual. For details on how to check error codes during servicing, refer to the following "Procedure for using the Self-Diagnosis Function (Error History Display Mode)".

Self-diagnosis Display

This system has a Self-diagnosis display function to let you know if there is a system malfunction. The display shows a code made up of three or five letters and a message alternately to show you the problem. To solve the problem refer to the following list. If any problem persists, consult your nearest Sony dealer.

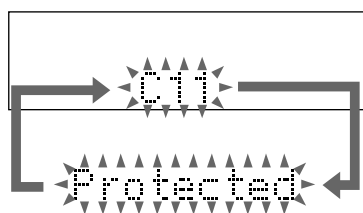

C11/Protected

The MD is protected against erasure.

→Remove the MD and slide the tab to close the slot (page 27).

C12/Cannot Copy

You tried to record a CD or MD with a format that the system does not support, such as a CD-ROM.

→Remove the disc and turn off the system once, then turn it on again.

C13/REC Error

Recording could not be performed properly.

→Move the system to a stable place, and start recording over from the beginning.

The MD is dirty or scratched, or the MD does not meet the standards.

→Replace the MD and start recording over from the beginning.

C13/Read Error

The MD deck cannot read the disc information properly.

→Remove the MD once, then insert it again.

C14/Toc Error

The MD deck cannot read the disc information properly.

→Replace the MD.

→Erase all the recorded contents of the MD using the All Erase function on page 44.

C41/Cannot Copy

The sound source is a copy of a commercially available music software, or you tried to record a CD-R (Recordable CD).

→The Serial Copy Management System prevents making a digital copy (see page 71). You cannot record a CD-R.

E0001/MEMORY NG

There is an error in the internal data that the system needs in order to operate.

→Consult your nearest Sony dealer.

E0101/LASER NG

There is a problem with the optical pickup.

→The optical pickup may have failed. Consult your nearest Sony dealer.

Messages

One of the following messages may appear or flash in the display during operation.

MD

Auto Cut

The MD deck is pausing the recording because silence continued for about 30 seconds or more during digital recording.

Blank Disc

The inserted recordable MD is new, or all tracks on the MD have been erased.

Cannot Edit

- A pre-mastered MD is in the deck.
- You tried to edit during Programme or Shuffle Play.
- You tried to change the recorded level or perform Fade-in or Fade-out operation after the Daily Timer or Recording Timer had activated and turned on the power.

Cannot REC

The function is switched to MD.

Complete!

The editing operation of MDs is completed.

Procedure for using the Self-Diagnosis Function (Error History Display Mode).

Note: Perform the self-diagnosis function in the "error history display mode" in the test mode. The following describes the least required procedure. Be careful not to enter other modes by mistake. If you set other modes accidentally, press the **[MENU/NO]** button to exit the mode.

Table of Error Codes

Error Code	Description
10	Could not load
12	Loading switches combined incorrectly
20	Timed out without reading the top of PTOC
21	Could read top of PTOC, but detected error
22	Timed out without accessing UTOC
23	Timed out without reading UTOC
24	Error in UTOC
30	Could not start playback
31	Error in sector
40	Retry cause generated during normal recording
41	Retried in DRAM overflow
42	Retry occurred during TOC writing
43	Retry aborted during S.F editing
50	Other than access processing, and could not read address.
51	Focus NG occurred and overran.

1. Clicking the **ENTER/YES** button and the **(DISC 5)** button while clicking the **(MD)** button causes the program to enter test mode and the message “Check” to be displayed on screen.
2. Rotate the **MD JOG** knob and when “[Service]” is displayed, press the **ENTER/YES** button.
3. Rotate the **MD JOG** knob and display “Err Display”.
4. Pressing the **ENTER/YES** button sets the error history mode and displays “op rec tm”.
5. Select the contents to be displayed or executed using the **MD JOG** knob.
6. Pressing the **MD JOG** knob will display or execute the contents selected.
7. Pressing the **MD JOG** knob another time returns to step 4.
8. Pressing the **MENU/NO** button displays “Err Display” and exits the error history mode.
9. To exit from test mode, enter MD mode and click the STR **REPEAT** button. The program will enter standby mode and then exit test mode.

ITEMS OF ERROR HISTORY MODE ITEMS AND CONTENTS

Selecting the Test Mode

Display	History
op rec tm	Displays the total recording time. When the total recording time is more than 1 minute, displays the hour and minute When less than 1 minute, displays “Under 1 min” The display time is the time the laser is set to high power, which is about 1/4 of the actual recording time.
op play tm	Displays the total playback time. When the total playback time is more than 1 minute, displays the hour and minute When less than 1 minute, displays “Under 1 min”
spdl rp tm	Displays the total rotating time of the spindle motor. When the total rotating time is more than 1 minute, displays the hour and minute When less than 1 minute, displays “Under 1 min”
retry err	Displays the total number of retry errors during recording and playback Displays “r xx p yy”. xx is the number of errors during recording, yy is the number of errors during playback. This is displayed in hexadecimal from 00 to FF.
total err	Displays the total number of errors Displays “total xx”. This is displayed in hexadecimal from 00 to FF.
err history	Displays the past ten errors. Displays “0x ErrCd @ @”. X is the history number. The younger the number, the more recent is the history (00 is the latest). @ @ is the error code. Select the error history number using the AMS knob.
retry adrs	Displays the past five retry addresses. Displays “xx ADRS yyyy”, xx is the history number, yyyy is the cluster with the retry error. Select the error history number using the AMS knob.
er refresh	Mode for erasing the error and retry address histories Procedure 1. Press the AMS knob when displayed as “er refresh”. 2. Press the YES button when the display changes to “er refresh?”. When “complete!” is displayed, it means erasure has completed. Be sure to check the following after executing this mode. *Data has been erased. *Perform recording and playback, and check that the mechanism is normal.
op change	Mode for erasing the total time of op rec tm, op play tm. These histories are based on the time of replacement of the optical pick-up. If the optical pick-up has been replaced, perform this procedure and erase the history. Procedure 1. Press the AMS knob when displayed as “op change”. 2. Press the YES button when the display changes to “op change?”. When “Complete!” is displayed, it means erasure has completed.
spdl change	Mode for erasing the total spdl rp tm time These histories are based on the time of replacement of the spindle motor. If the spindle motor has been replaced, perform this procedure and erase the history. Procedure 1. Press the AMS knob when displayed as “spdl change” 2. Press the YES button when the display changes to “spdl change?” When “Complete!” is displayed, it means erasure has completed.

TABLE OF CONTENTS

1. SERVICING NOTES	4
2. GENERAL	12
3. DISASSEMBLY	
3-1. Case	13
3-2. Front Panel Section	13
3-3. CD Mechanism Deck Section	14
3-4. MD Mechanism Deck Block	14
3-5. CD Base Unit	15
3-6. Main Board	15
3-7. Fitting Base (Guide) Assy, Bracket (Chassis) and Magnet Assy	16
3-8. Tray (Sub)	16
3-9. Chassis (Mold B) Section, Stocker Section and Slider (Selection)	17
3-10. Gears Installation	17
3-11. Slider (Selection) Installation	18
3-12. Stocker Section Installation	18
3-13. Chassis (Mold B) Section Installation	19
3-14. MD Mechanism Deck Section	19
3-15. BD (MD) Board	20
4. TEST MODE	21
5. ELECTRICAL ADJUSTMENT	27
6. DIAGRAMS	
6-1. Circuit Boards Location	39
6-2. Block Diagrams	41
6-3. Schematic Diagram – CD Section –	44
6-4. Printed Wiring Board – CD Section –	45
6-5. Printed Wiring Board – MD Section –	46
6-6. Schematic Diagram – MD Section (1/2) –	47
6-7. Schematic Diagram – MD Section (2/2) –	48
6-8. Schematic Diagram – Main Section (1/2) –	49
6-9. Schematic Diagram – Main Section (2/2) –	50
6-10. Printed Wiring Board – Main Section –	51
6-11. Schematic Diagram – Digital Section –	52
6-12. Printed Wiring Board – Digital Section –	53
6-13. Schematic Diagram – Panel Section –	54
6-14. Printed Wiring Board – Panel Section –	55
6-15. Schematic Diagram – CD Mechanism Section –	56
6-16. Printed Wiring Board – CD Mechanism Section –	57
6-17. IC Block Diagrams	58
6-18. IC Pin Function	62
7. EXPLODED VIEW	
7-1. Case, Chassis Section	71
7-2. Front Panel Section	72
7-3. CD Mechanism Deck Section-1	73
7-4. CD Mechanism Deck Section-2	74
7-5. CD Base Unit Section	75
7-6. MD Mechanism Section-1	76
7-7. MD Mechanism Section-2	77
8. ELECTRICAL PARTS LIST	78

SAFETY-RELATED COMPONENT WARNING!!

COMPONENTS IDENTIFIED BY MARK \triangle OR DOTTED LINE WITH MARK \triangle ON THE SCHEMATIC DIAGRAMS AND IN THE PARTS LIST ARE CRITICAL TO SAFE OPERATION. REPLACE THESE COMPONENTS WITH SONY PARTS WHOSE PART NUMBERS APPEAR AS SHOWN IN THIS MANUAL OR IN SUPPLEMENTS PUBLISHED BY SONY.

SECTION 1 SERVICING NOTES

NOTES ON HANDLING THE OPTICAL PICK-UP BLOCK OR BASE UNIT

The laser diode in the optical pick-up block may suffer electrostatic break-down because of the potential difference generated by the charged electrostatic load, etc. on clothing and the human body.

During repair, pay attention to electrostatic break-down and also use the procedure in the printed matter which is included in the repair parts.

The flexible board is easily damaged and should be handled with care.

FOR CD

NOTES ON LASER DIODE EMISSION CHECK

The laser beam on this model is concentrated so as to be focused on the disc reflective surface by the objective lens in the optical pick-up block. Therefore, when checking the laser diode emission, observe from more than 30 cm away from the objective lens.

FOR MD

NOTES ON LASER DIODE EMISSION CHECK

Never look into the laser diode emission from right above when checking it for adjustment. It is feared that you will lose your sight.

Laser component in this product is capable of emitting radiation exceeding the limit for Class 1.

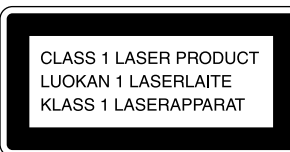

This appliance is classified as a CLASS 1 LASER product. The CLASS 1 LASER PRODUCT MARKING is located on the rear exterior.



This caution label is located inside the unit.

CAUTION

Use of controls or adjustments or performance of procedures other than those specified herein may result in hazardous radiation exposure.

Notes on chip component replacement

- Never reuse a disconnected chip component.
- Notice that the minus side of a tantalum capacitor may be damaged by heat.

Flexible Circuit Board Repairing

- Keep the temperature of soldering iron around 270°C during repairing.
- Do not touch the soldering iron on the same conductor of the circuit board (within 3 times).
- Be careful not to apply force on the conductor when soldering or unsoldering.

POWER SUPPLY DURING SERVICING

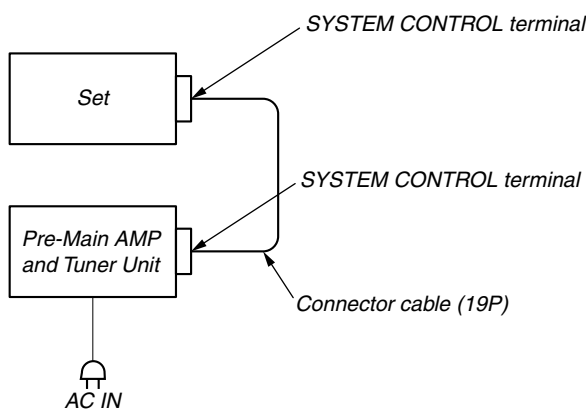

- As this set has not own power supply, it does not operate independently. Therefore, during servicing, connect it to the Pre-Main amplifier and Tuner Unit (STR-NX5MD) of DHC-NX5MD.







If STR-NX5MD are not available, use the Power Feed Jig (PFJ-1) and Relay Connector Jig.

In this case, after turn on the POWER switch on the Power Feed Jig, supply power with the following methods.

Procedure:

- Press three buttons of  (MD), , and  simultaneously.

function	button
CD AMS -	AMS -
AMS +	AMS +
FR	
FF	
MD AMS -	AMS -
AMS +	AMS +
FR	
FF	

Connection:

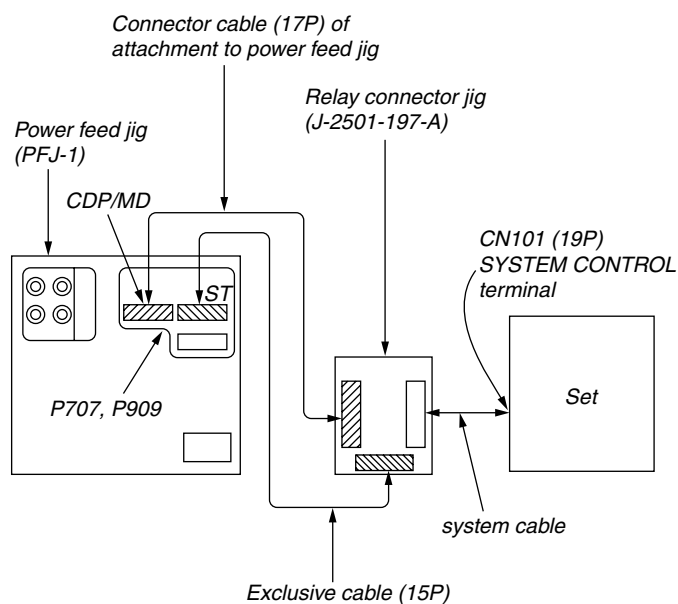

OPTICAL PICK-UP CLEANING

❶ Remove the case. (Refer to disassembly page 13)

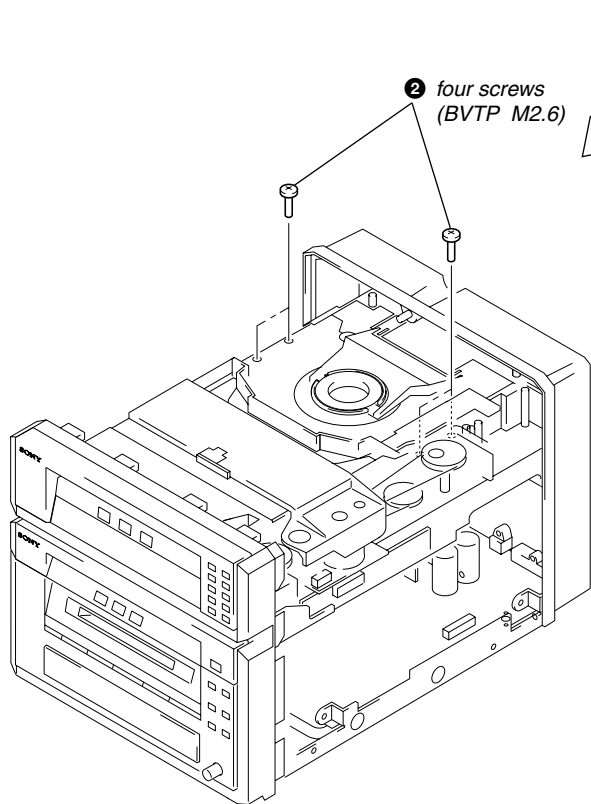
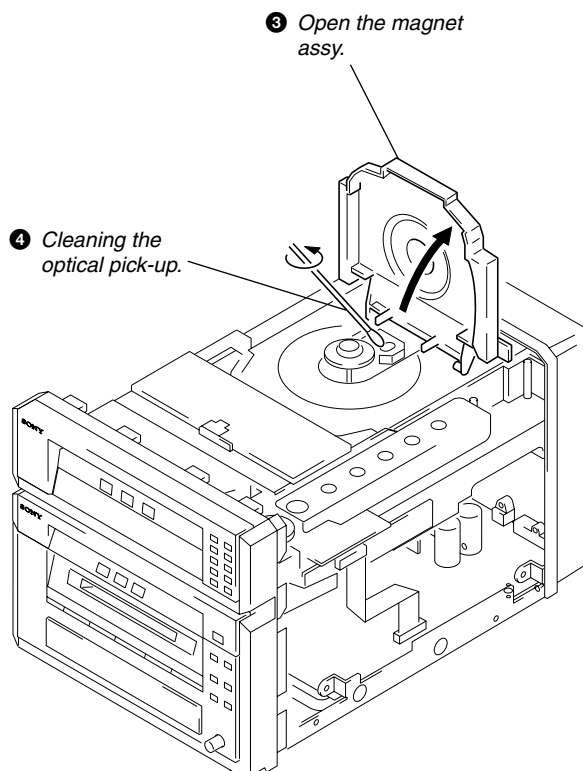

- Note 1: In cleaning the lens, do not apply an excessive force. As the optical pick-up is vulnerable, application of excessive force could damage the lens holder.*
- Note 2: In cleaning, do not use a cleaner other than exclusive cleaning liquid (KK-91 or isopropyl alcohol).*
- Note 3: Wipe the objective lens spirally from center toward outside. (See Figure A)*

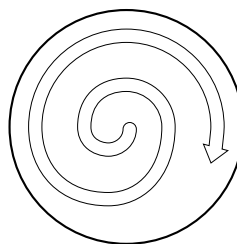

(Figure A)

JIG FOR CHECKING BD (MD) BOARD WAVEFORM

The special jig (J-2501-196-A) is useful for checking the waveform of the BD (MD) board. The names of terminals and the checking items to be performed are shown as follows.

- GND : Ground
- I+3V : For measuring IOP (Check the deterioration of the optical pick-up laser)
- IOP : For measuring IOP (Check the deterioration of the optical pick-up laser)
- TE : TRK error signal (Traverse adjustment)
- VC : Reference level for checking the signal
- RF : RF signal (Check jitter)
- FE : Focus error signal

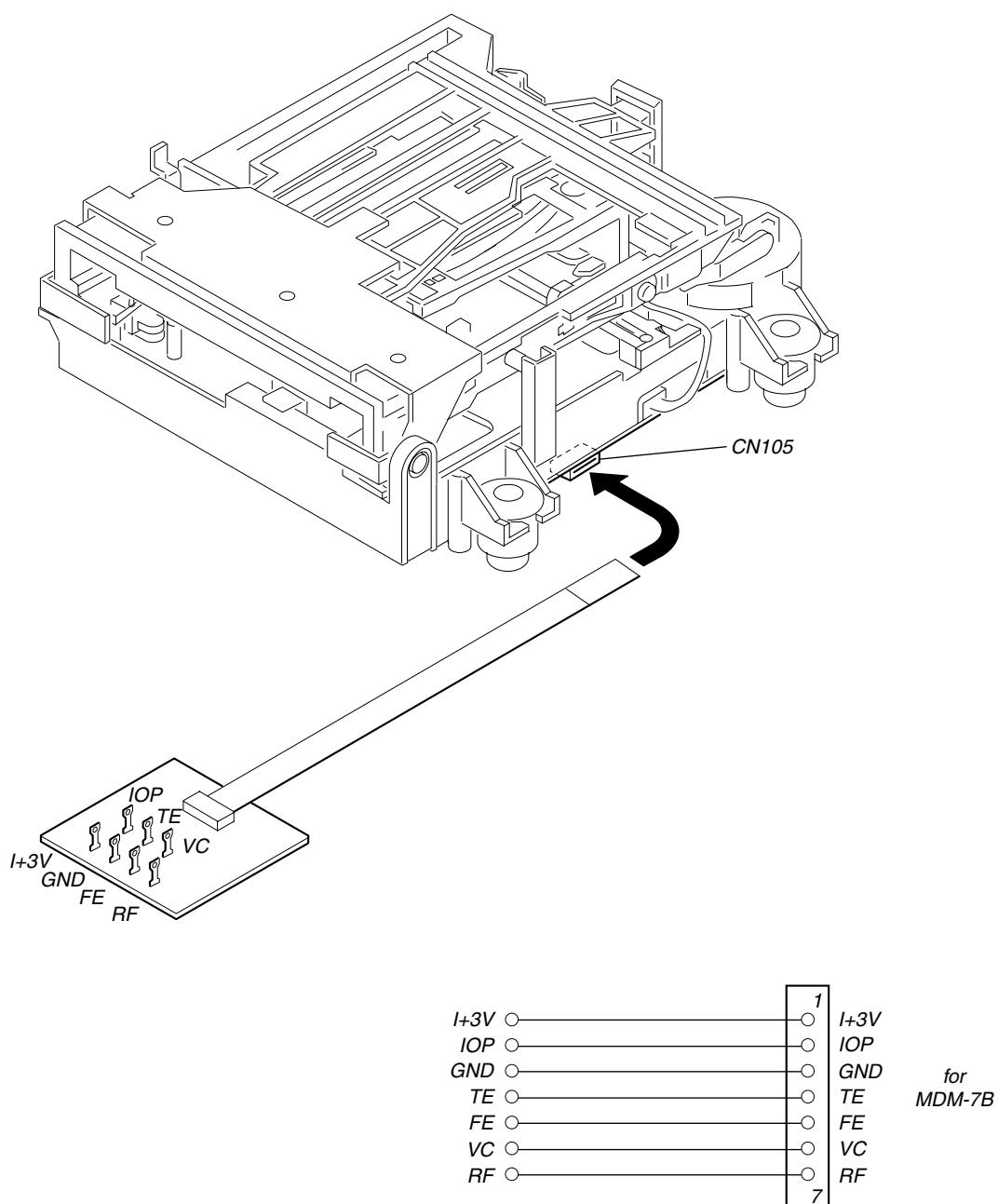

Iop DATA RECORDING AND DISPLAY WHEN OPTICAL PICK-UP AND NON-VOLATILE MEMORY (IC195 OF BD BOARD) ARE REPLACED

The Iop value labeled on the optical pick-up can be recorded in the non-volatile memory. By recording the value, it will eliminate the need to look at the value on the label of the optical pick-up. When replacing the optical pick-up or non-volatile memory (IC195 of BD board), record the Iop value on the optical pick-up according to the following procedure.

Record Procedure:

1. Clicking the **ENTER/YES** button and the **DISC 5** button while clicking the **MD** button causes the program to enter test mode and the message "Check" to be displayed on screen.
2. Rotate the **MD JOG** knob to display "[Service]", and press the **ENTER/YES** button.
3. Rotate the **MD JOG** knob to display "Iop Write" (C05), and press the **ENTER/YES** button.
4. The display becomes "Ref=@@.@@" (@ is an arbitrary number) and the numbers which can be changed will blink.
5. Input the Iop value written on the optical pick-up.
To select the number : Rotate the **MD JOG** knob.
To select the digit : Press the **MD JOG** knob.
6. When the **ENTER/YES** button is pressed, the display becomes "Measu=@@.@@" (@ is an arbitrary number).
7. As the adjustment results are recorded for the 6 value. Leave it as it is and press the **ENTER/YES** button.
8. "Complete!" will be displayed momentarily. The value will be recorded in the non-volatile memory and the display will become "Iop Write" (C05).
9. Press the STR **REPEAT** button to complete.

Display Procedure:

1. Clicking the **ENTER/YES** button and the **DISC 5** button while clicking the **MD** button causes the program to enter test mode and the message "Check" to be displayed on screen.
2. Rotate the **MD JOG** knob to display "[Service]", and press the **ENTER/YES** button.
3. Rotate the **MD JOG** knob to display "Iop Read" (C26).
4. "@@.@/###.#" is displayed and the recorded contents are displayed.
@@.@ : indicates the Iop value labeled on the pick-up.
###.# : indicates the Iop value after adjustment
5. To end, press the **MD JOG** button or **MENU/NO** button to display "Iop Read" (C26). Then press the **REPEAT** button.

CHECKS PRIOR TO PARTS REPLACEMENT AND ADJUSTMENTS

Before performing repairs, perform the following checks to determine the faulty locations up to a certain extent. Details of the procedures are described in “5 Electrical Adjustments”.

- 5-6-2. Laser power check (see page 31)
- 5-6-3. Iop Compare (see page 31)
- 5-6-4. Auto Check (see page 32)

Note:

The criteria for determination above is intended merely to determine if satisfactory or not, and does not serve as the specified value for adjustments.

When performing adjustments, use the specified values for adjustments.

RETRY CAUSE DISPLAY MODE

- In this test mode, the causes for retry of the unit during recording can be displayed on the fluorescent indicator tube. During playback, the “track mode” for obtaining track information will be set. This is useful for locating the faulty part of the unit.
- The following will be displayed :
 - During recording and stop : Retry cause, number of retries, and number of retry errors.
 - During playback : Information such as type of disc played, part played, copyright.
 These are displayed in hexadecimal.

Procedure:

- Press the **ENTER/YES** button while pressing the **DISC 5** button and **NAME EDIT/CHARACTER** button.
- Press the **REC/RECIT** button to start recording. Then press the **RECORD** button and start recording.
- To check the “track mode”, press the **TRACK** button to start play.
- To exit the test mode, press the **POWER** button, and turn OFF the power. When “TOC” disappears, disconnect the power plug from the outlet.

Fig. 1 Reading the Test Mode Display (During recording and stop)

RTs@@c##c***

Fluorescent display tube display

- @@ : Cause of retry
- ## : Number of retries
- *** : Number of retry errors

Fig. 2 Reading the Test Mode Display (During playback)

@@#####\$\$

Fluorescent display tube display

- @@ : Parts No. (name of area named on TOC)
- ## : Cluster } Address (Physical address on disc)
- ** : Sector }
- \$\$: Track mode (Track information such as copyright information of each part)

Reading the Retry Cause Display

Hexadecimal	Higher Bits				Lower Bits				Hexa-decimal	Cause of Retry	Occurring conditions
	b7	b6	b5	b4	b3	b2	b1	b0			
Binary	0	0	0	0	0	0	0	1	01	shock	When track jump (shock) is detected
	0	0	0	0	0	0	1	0	02	ader5	When ADER was counted more than five times continuously
	0	0	0	0	0	1	0	0	04	Discontinuous address	When ADIP address is not continuous
	0	0	0	0	1	0	0	0	08	DIN unlock	When DIN unlock is detected
	0	0	0	1	0	0	0	0	10	FCS incorrect	When not in focus
	0	0	1	0	0	0	0	0	20	IVR rec error	When ABCD signal level exceeds the specified range
	0	1	0	0	0	0	0	0	40	CLV unlock	When CLV is unlocked
	1	0	0	0	0	0	0	0	80	Access fault	When access operation is not performed normally

Reading the Display:

Convert the hexadecimal display into binary display. If more than two causes, they will be added.

Example

When 42 is displayed:
 Higher bit : 4 = 0100 → b6
 Lower bit : 2 = 0010 → b1
 In this case, the retry cause is combined of “CLV unlock” and “ader5”.

When A2 is displayed:
 Higher bit : A = 1010 → b7+b5
 Lower bit : 2 = 0010 → b1
 The retry cause in this case is combined of “Access fault”, “IVR rec error”, and “ader5”.

Reading the Track Mode Display

Hexadecimal	Higher Bits				Lower Bits				Hexa- decimal	Details	
	8	4	2	1	8	4	2	1		When 0	When 1
Bit	b7	b6	b5	b4	b3	b2	b1	b0			
Binary	0	0	0	0	0	0	0	1	01	Emphasis OFF	Emphasis ON
	0	0	0	0	0	0	1	0	02	Monaural	Stereo
	0	0	0	0	0	1	0	0	04	This is 2-bit display. Normally 01.	
	0	0	0	0	1	0	0	0	08	01:Normal audio. Others:Invalid	
	0	0	0	1	0	0	0	0	10	Audio (Normal)	Invalid
	0	0	1	0	0	0	0	0	20	Original	Digital copy
	0	1	0	0	0	0	0	0	40	Copyright	No copyright
	1	0	0	0	0	0	0	0	80	Write prohibited	Write allowed

Reading the Display:

Convert the hexadecimal display into binary display. If more than two causes, they will be added.

Example When 84 is displayed:

Higher bit : 8 = 1000 → b7

Lower bit : 4 = 0100 → b2

In this case, as b2 and b7 are 1 and others are 0, it can be determined that the retry cause is combined of “Emphasis OFF”, “Monaural”, “Original”, “Copyright exists”, and “Write allowed”.

Example When 07 is displayed:

Higher bit : 0 = 1000 → All 0

Lower bit : 7 = 0111 → b0+b1+b2

In this case, as b0, b1, and b2 are 1 and others are 0, it can be determined that the retry cause is combined of “Emphasis ON”, “Stereo”, “Original”, “Copyright exists”, and “Write prohibited”.

Hexadecimal → Binary Conversion Table

Hexadecimal	Binary	Hexadecimal	Binary
0	0000	8	1000
1	0001	9	1001
2	0010	A	1010
3	0011	B	1011
4	0100	C	1100
5	0101	D	1101
6	0110	E	1110
7	0111	F	1111

SECTION 2 GENERAL

• LOCATION OF CONTROLS

– Front Panel –

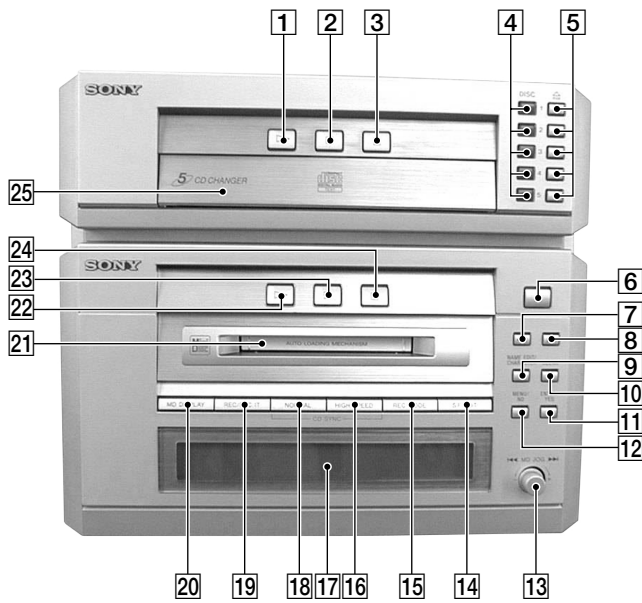

- 1 ▷ (CD) button
- 2 ▢ (CD) button
- 3 □ (CD) button
- 4 DISC 1 to 5 (CD) button and indicator
- 5 ≡ (CD DISC 1 to 5) button
- 6 ≡ (MD) button
- 7 ◀◀ (MD) button
- 8 ▶▶ (MD) button
- 9 NAME EDIT/CHARACTER button
- 10 CLEAR button
- 11 MENU/NO button
- 12 ENTER/YES button
- 13 ◀◀ MD JOG ▶▶ +/- dial
- 14 S.F EDIT button
- 15 REC MODE button
- 16 HIGH SPEED button
- 17 Display window
- 18 NORMAL button
- 19 REC/REC IT button
- 20 MD DISPLAY button
- 21 MD disc compartment
- 22 ▷ (MD) button
- 23 ▢ (MD) button
- 24 □ (MD) button
- 25 CD disc tray

SECTION 3 DISASSEMBLY

Note: Follow the disassembly procedure in the numerical order given.

3-1. CASE

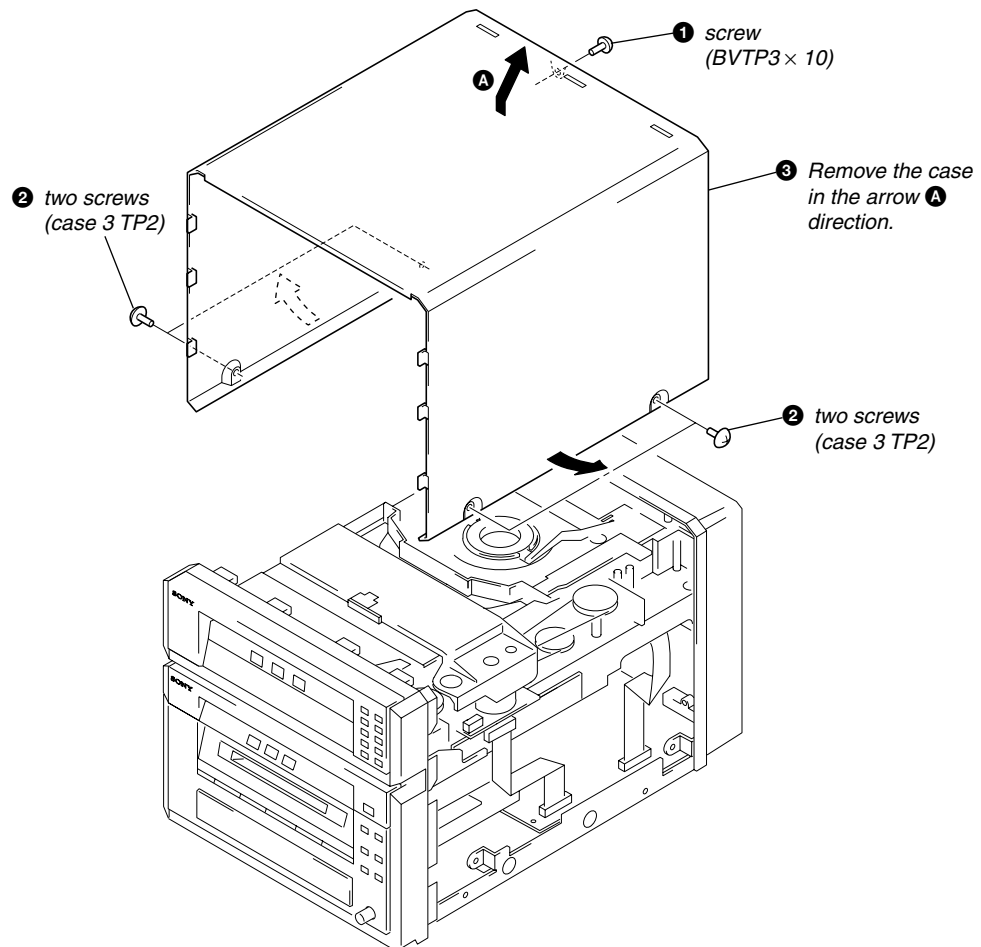

3-2. FRONT PANEL SECTION

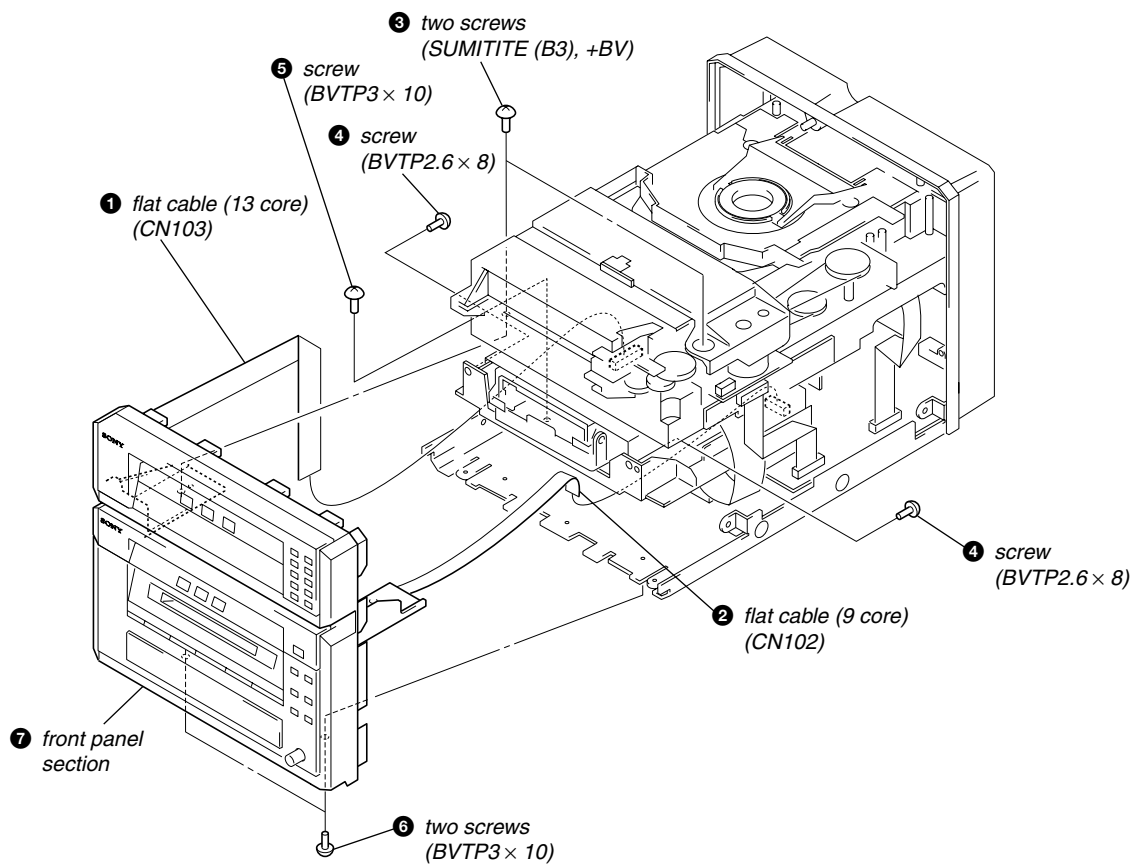

3-3. CD MECHANISM DECK SECTION (CDM53E-K4BD40)

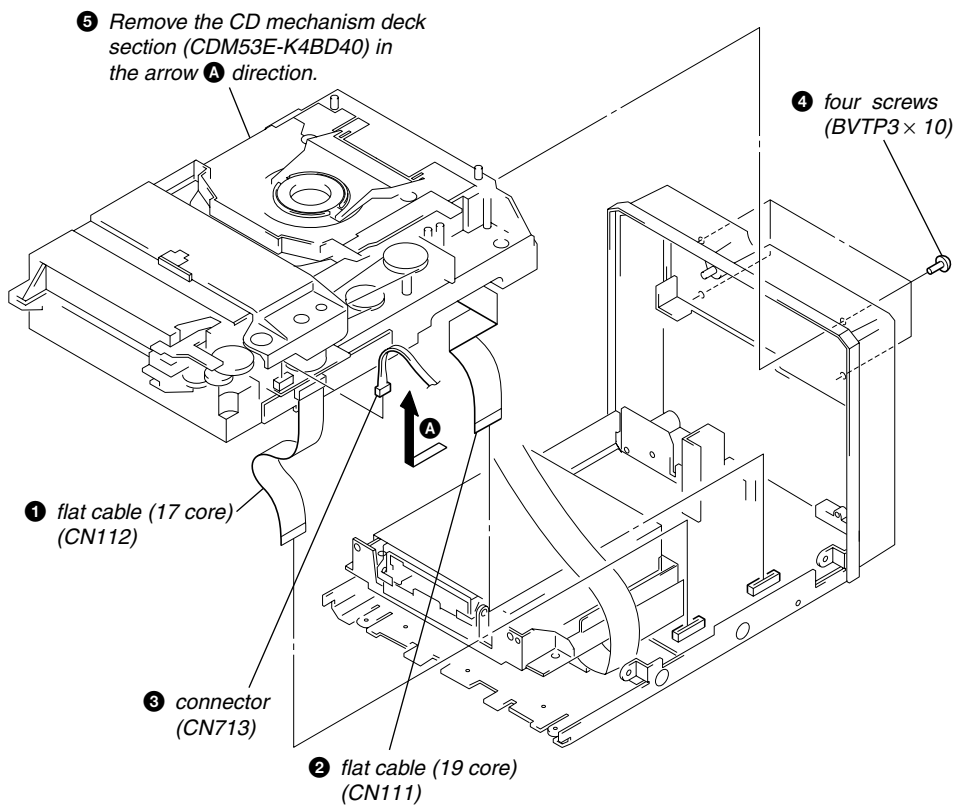

3-4. MD MECHANISM DECK BLOCK

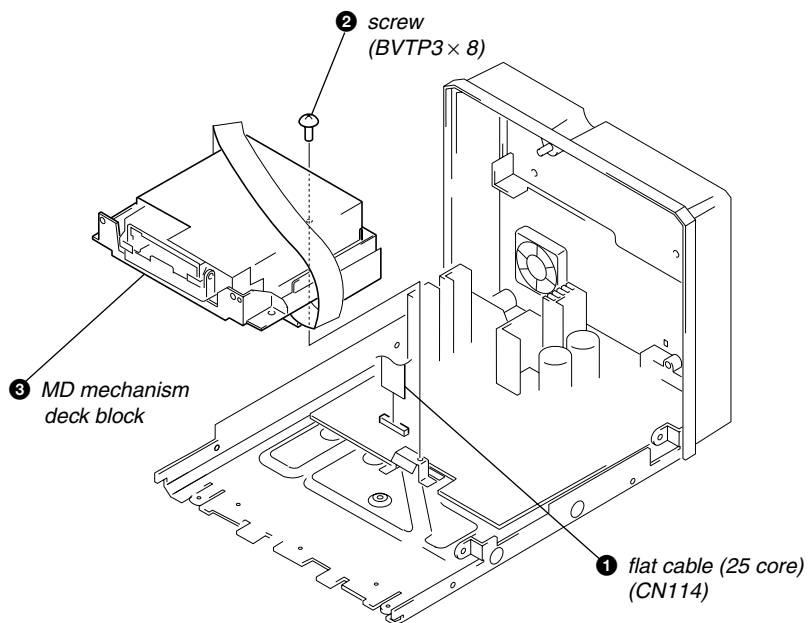

3-5. CD BASE UNIT (BU-K4BD40)

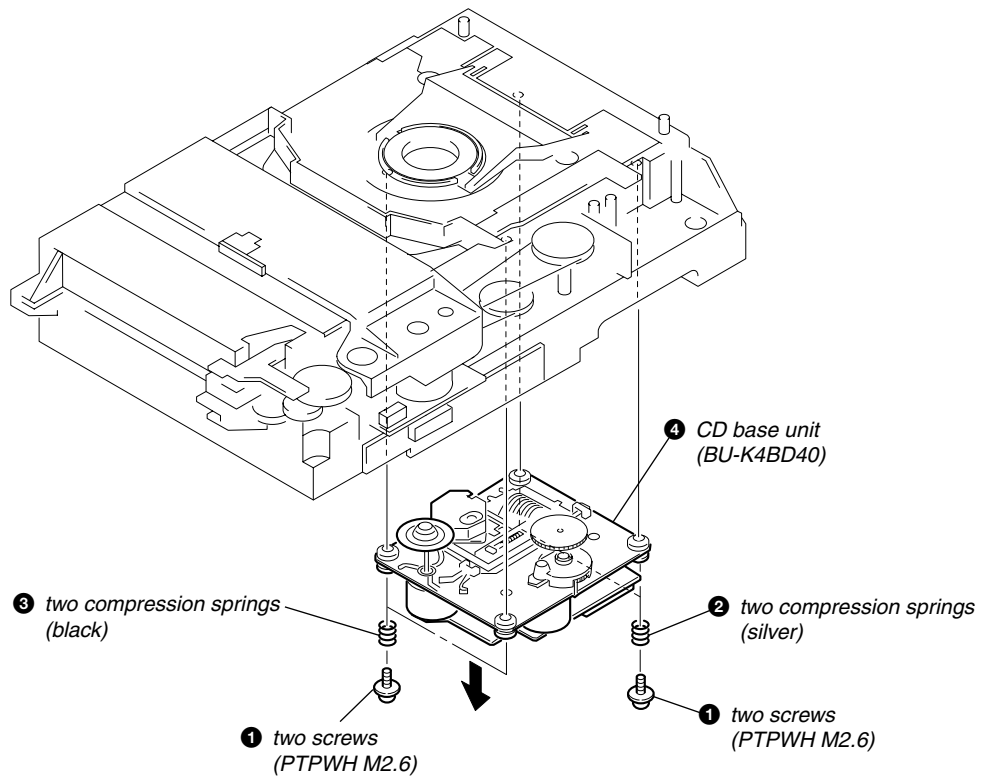

3-6. MAIN BOARD

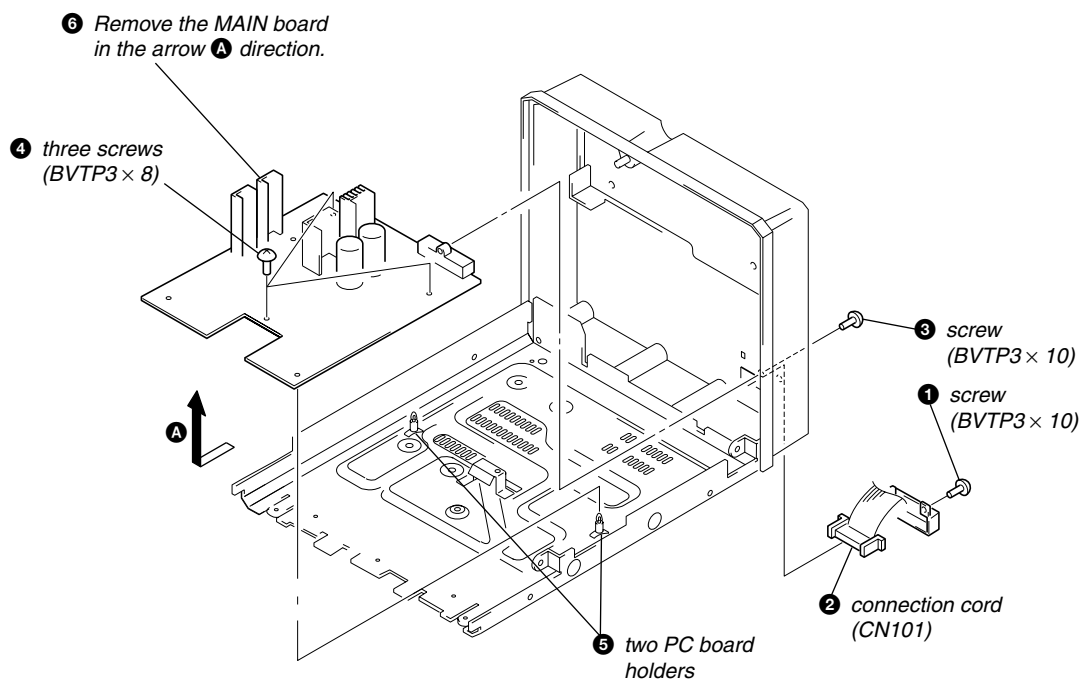

3-7. FITTING BASE (GUIDE) ASSY, BRACKET (CHASSIS) AND MAGNET ASSY

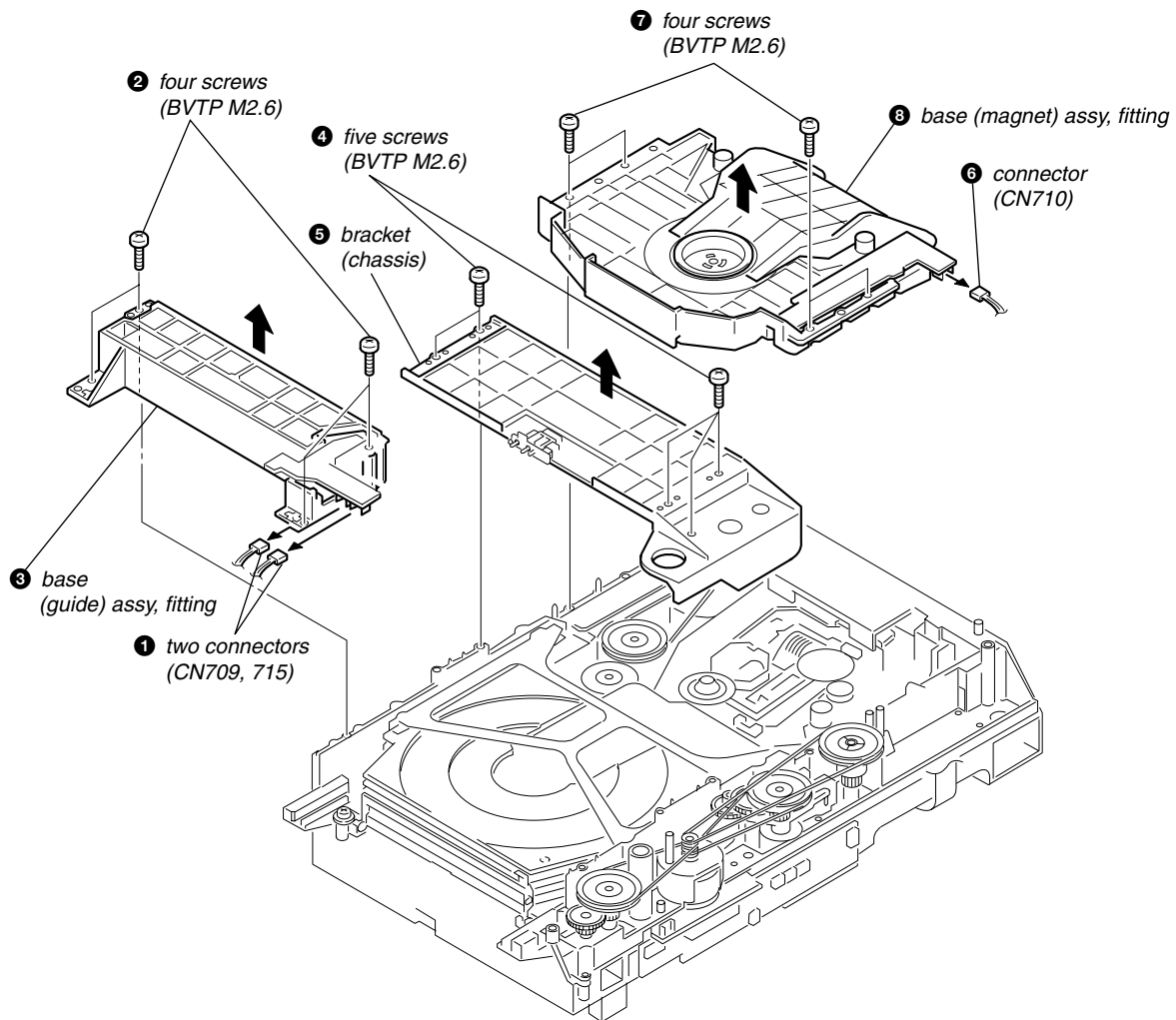

3-8. TRAY (SUB)

- ① Rotating the pulley (LD), shift the slider (selection) in the arrow **A** direction.
- ② Rotating the pulley (mode) in the arrow direction, adjust the tray (sub) to be removed.
- ③ Rotating the pulley (LD), shift the slider (selection) in the arrow **B** direction.
- ④ Rotating the pulley (mode) in the arrow direction, remove the tray (sub) to be removed.

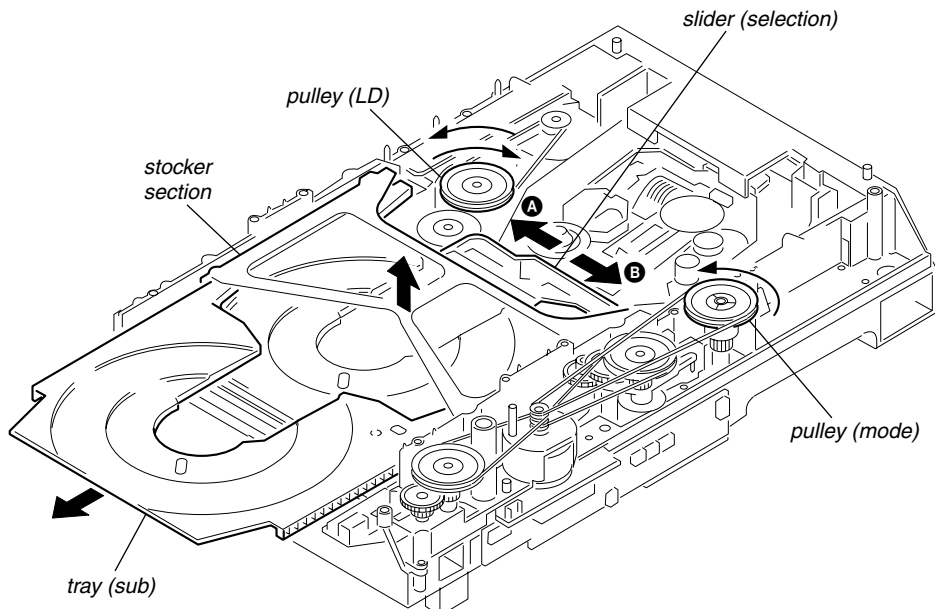

3-9. CHASSIS (MOLD B) SECTION, STOCKER SECTION AND SLIDER (SELECTION)

Note: In mounting the parts, refer to page 18 and 19.

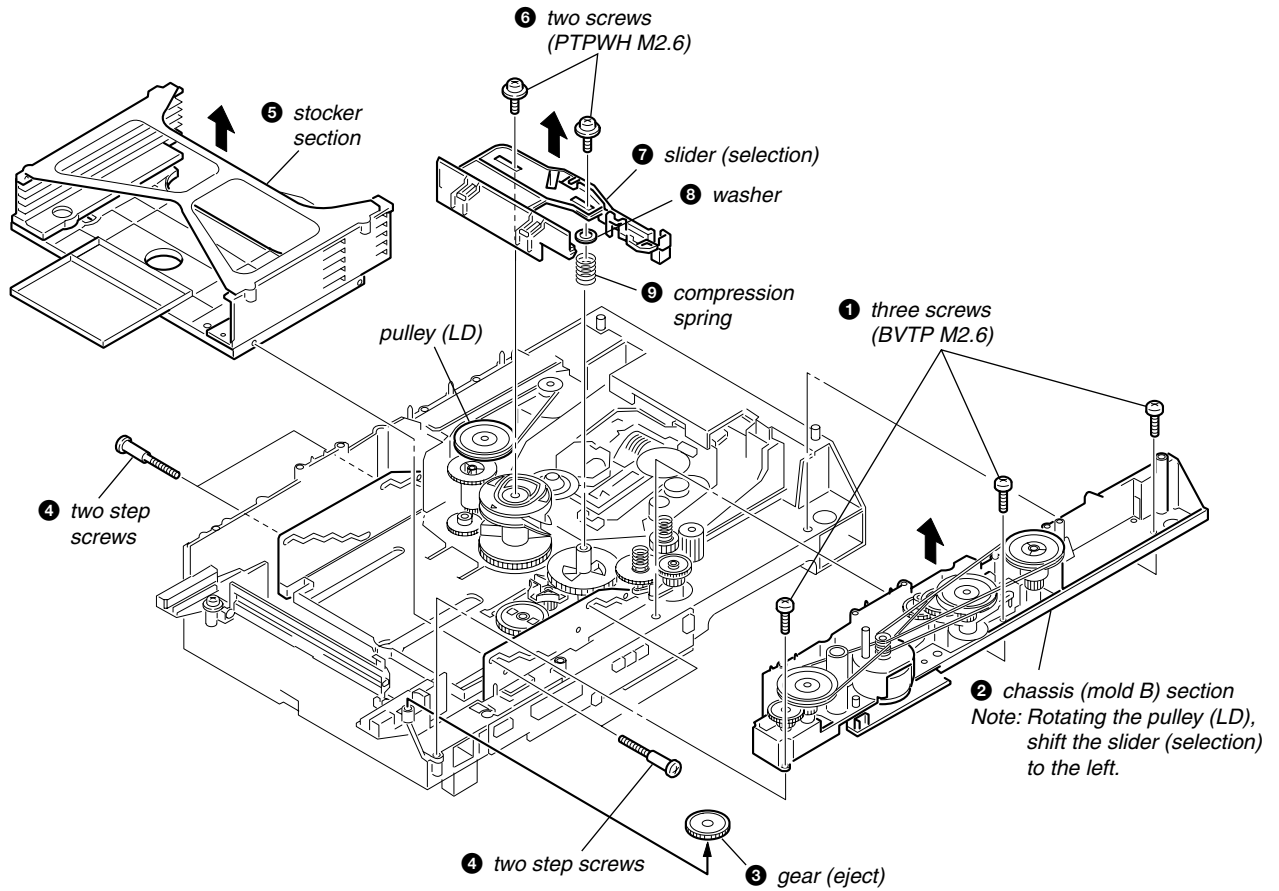

3-10. GEARS INSTALLATION

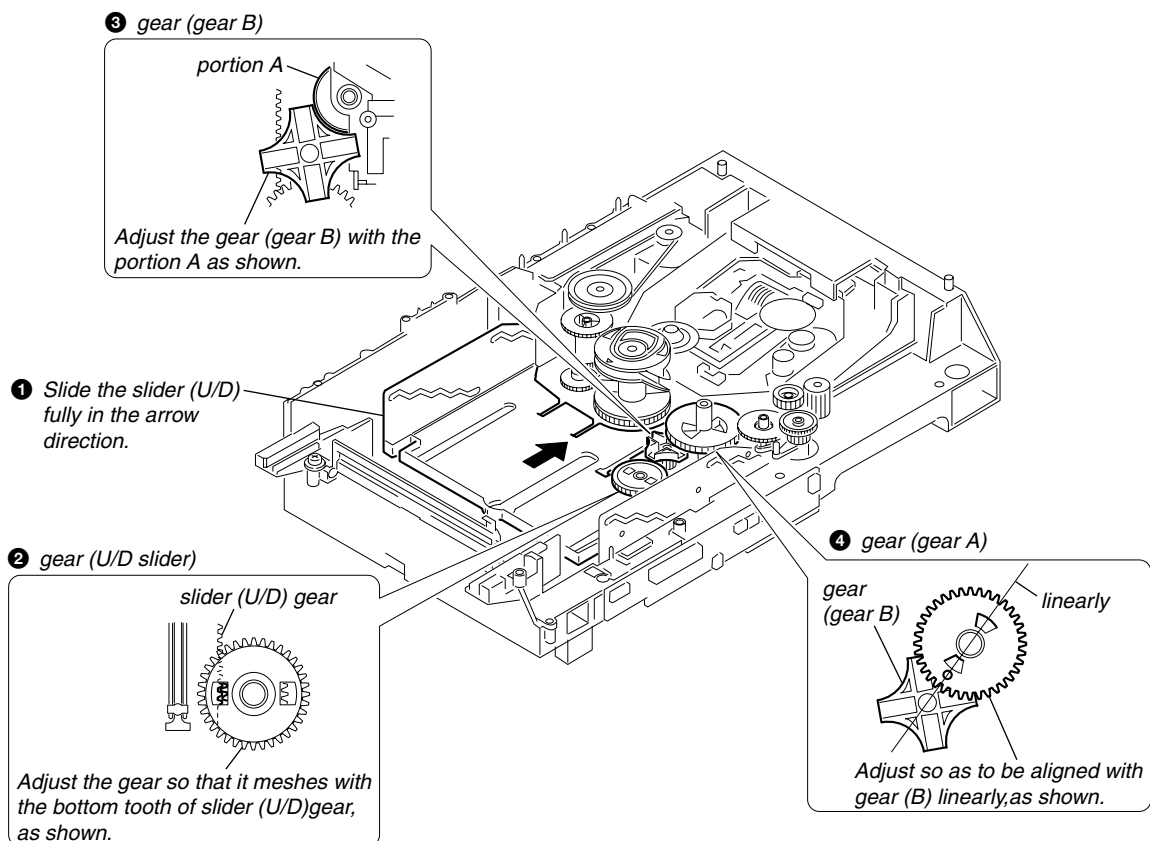

3-11. SLIDER (SELECTION) INSTALLATION

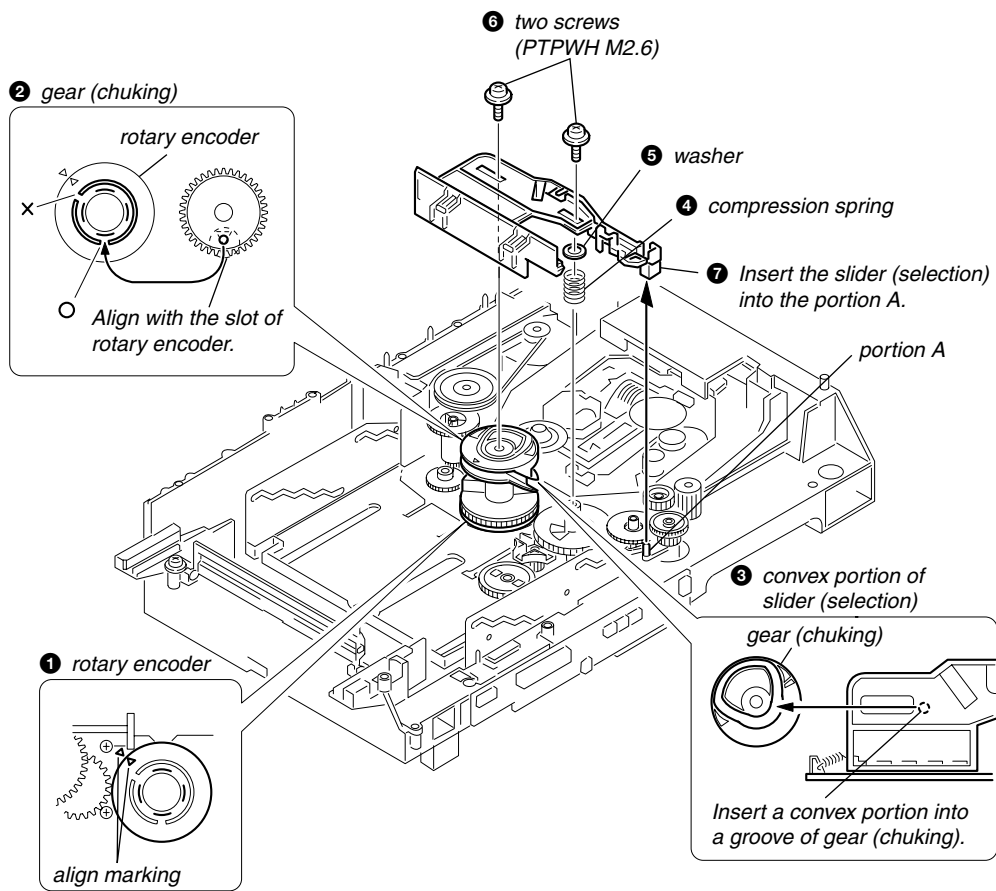

3-12. STOCKER SECTION INSTALLATION

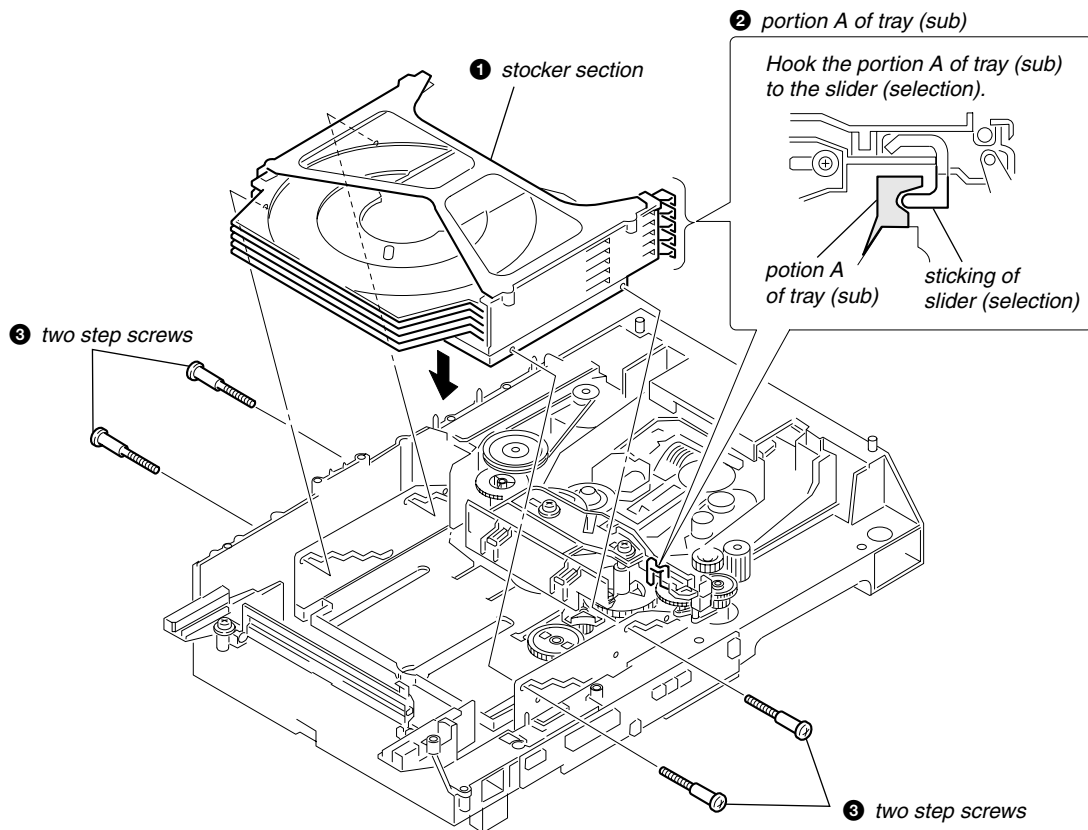

3-13. CHASSIS (MOLD B) SECTION INSTALLATION

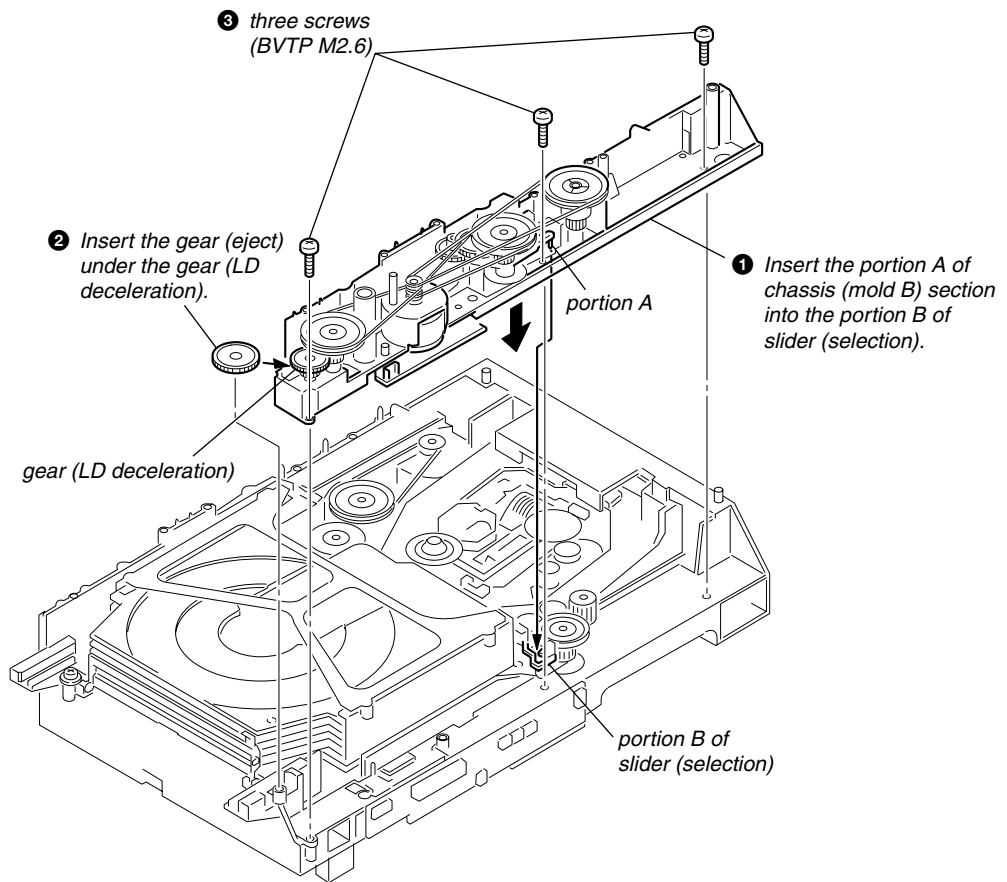

3-14. MD MECHANISM DECK SECTION (MDM-7B)

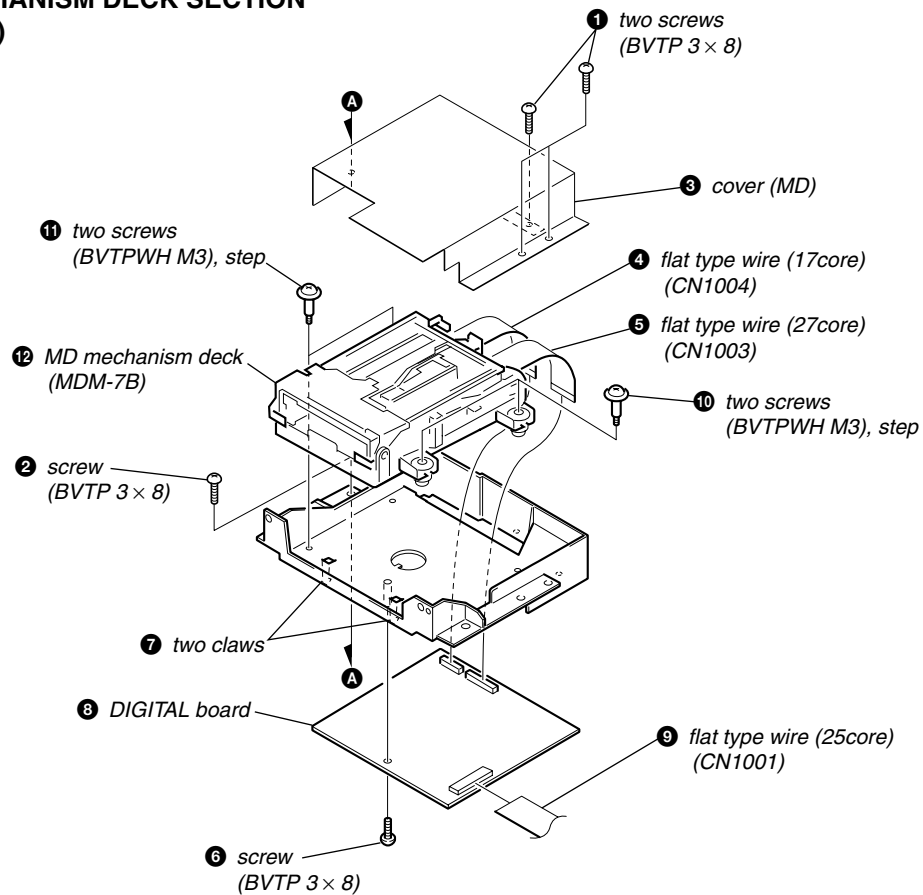



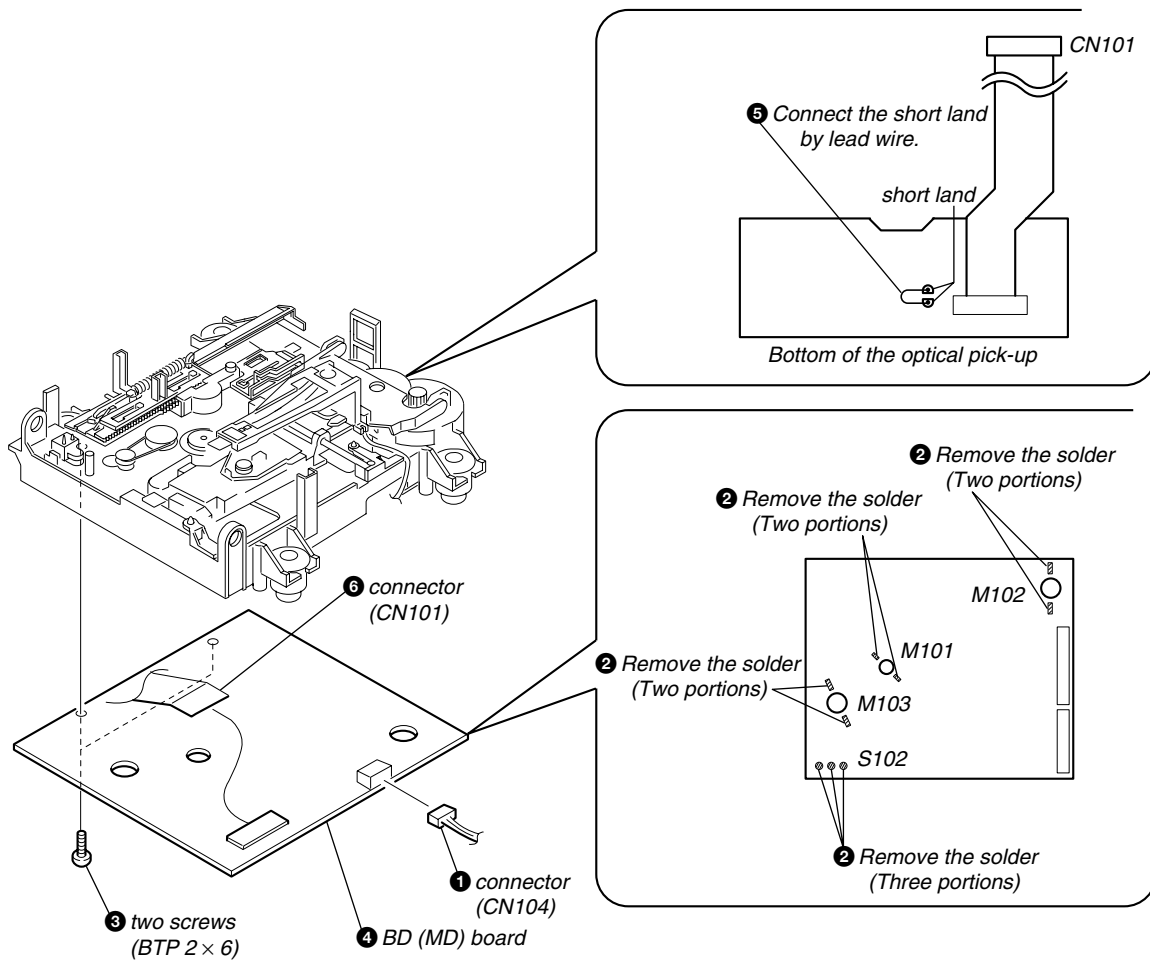

3-15. BD (MD) BOARD



SECTION 4 TEST MODE



[LED All Lit, Key Check Mode]

Procedure:

1. Press the  button to turn the power ON.
2. Press three buttons of  (MD),  (DISC 1), and  simultaneously.
3. LEDs are all turned on.
Press the  (CD) button, and the key check mode is activated.
4. To release from this mode, press three buttons in the same manner as step 2, or remove the power cord.

[COLD RESET]



Procedure:

1. Press the  button to turn the power ON.
2. Press  (MD) and  (CD) buttons simultaneously.

[CD Delivery Mode]

- This mode moves the optical pick-up to the position durable to vibration. Use this mode when returning the set to the customer after repair.

Procedure:





1. Press the  button to turn the power ON.
2. Press the  (MD) and  buttons simultaneously.
3. A message "LOCK" is displayed on the liquid crystal display of the STR-NX5MD, and the CD delivery mode is set.

[CD/MD Test Mode]

(In case of connected to the STR-NX5MD)

- If connected to the STR-NX5MD, the mode also acts as the STR-NX5MD amplifier test mode.



Procedure:

1. Press the  button to turn the power ON.
2. Press three buttons of  +  and  of the STR-NX5MD simultaneously.
3. On liquid crystal display of the STR-NX5MD, the disc calendar blinks, then the function which was set before the test mode became active is displayed.





[CD/MD Test Mode]

(In case of connected to the power feed jig)



Procedure:

1. Turn on the Power switch on the power feed jig.
2. Press three buttons of  (MD),  (DISC 1), and  (CD) simultaneously.
3. Also, the other functions are enabled by pressing two buttons simultaneously.

A combination of respective functions and buttons is as follows.

function	button
CD AMS –	AMS –
AMS +	AMS +
FR	
FF	
MD AMS –	AMS –
AMS +	AMS +
FR	
FF	

4-1. PRECAUTIONS FOR USE OF TEST MODE



- As loading related operations will be performed regardless of the test mode operations being performed, be sure to check that the disc is stopped before setting and removing it.
Even if the  (MD) button is pressed while the disc is rotating during continuous playback, continuous recording, etc., the disc will not stop rotating.
Therefore, it will be ejected while rotating.
Be sure to press the  (MD) button after pressing the  button and the rotation of disc is stopped.

4-1-1. Recording laser emission mode and operating buttons

- Continuous recording mode (CREC 1MODE) (C35)
- Laser power check mode (LDPWR CHECK) (C13)
- Laser power adjustment mode (LDPWR ADJUS) (C04)
- Iop check (Iop Compare) (C27)
- Iop value nonvolatile writing (Iop NV Save) (C06)
- Traverse (MO) check (EF MO CHECK) (C14)
- Traverse (MO) adjustment (EF MO ADJUS) (C07)
- When pressing the  button.

4-2. SETTING THE TEST MODE

The following are two methods of entering the test mode.

Procedure: Pressing the  button and the  (DISC 5) button while pressing the  (MD) button causes the program to enter test mode.

When the test mode is set, “[Check]” will be displayed. Rotating the  knob switches between the following three groups; ... ↔ Check ↔ Service ↔ Develop ↔

NOTE: Do not use the test mode in the [Develop] group.



If used, the unit may not operate normally.

If the [Develop] group is set accidentally, press the  button immediately to exit the [Develop] group.

4-3. EXITING THE TEST MODE

Press the  button. The disc is ejected when loaded, and “Standby” display blinks, and the STANDBY state is set.

4-4. BASIC OPERATIONS OF THE TEST MODE

All operations are performed using the  knob,  button, and  button.

The functions of these buttons are as follows.

Function name		Function
MENU/NO button		Cancel or move to top hierarchy
ENTER/YES button		Set
AMS knob	Left or Right	Select
	Push	Set submenu

4-5. SELECTING THE TEST MODE

There are 26 types of test modes as shown below. The groups can be switched by rotating the [MD JOG] knob. After selecting the group to be used, press the [ENTER/YES] button. After setting a certain group, rotating the [MD JOG] knob switches between these modes.

Refer to “Group” in the table for details selected.

All adjustments and checks during servicing can be performed in the test mode in the Service group.

NOTE: Do not use the test mode in the [Develop] group.

If used, the unit may not operate normally.

If the [Develop] group is set accidentally, press the [MENU/NO] button immediately to exit the [Develop] group.

Display	No.	Details	Mark	Group	
				Check	Service
AUTO CHECK	C01	Automatic self-diagnosis			○
Err Display	C02	Error history display, clear			○
TEMP ADJUS	C03	Temperature compensation offset adjustment			○
LDPWR ADJUS	C04	Laser power adjustment			○
Iop Write	C05	Iop data writing			○
Iop NV Save	C06	Writes current Iop value in read nonvolatile memory using microprocessor			○
EF MO ADJUS	C07	Traverse (MO) adjustment			○
EF CD ADJUS	C08	Traverse (CD) adjustment			○
FBIAS ADJUS	C09	Focus bias adjustment			○
AG Set (MO)	C10	Focus, tracking gain adjustment (MO)			○
AG Set (CD)	C11	Focus, tracking gain adjustment (CD)			○
TEMP CHECK	C12	Temperature compensation offset check		○	○
LDPWR CHECK	C13	Laser power check		○	○
EF MO CHECK	C14	Traverse (MO) check		○	○
EF CD CHECK	C15	Traverse (CD) check		○	○
FBIAS CHECK	C16	Focus bias check		○	○
ScurveCHECK	C17	S-curve check	×	○	
VERIFYMODE	C18	Nonvolatile memory check	×	○	
DETRK CHECK	C19	Detrack check	×	○	
0920 CHECK	C25	Most circumference check	×	○	
Iop Read	C26	Iop data display		○	○
Iop Compare	C27	Comparison with initial Iop value written in nonvolatile memory		○	○
ADJ CLEAR	C28	Initialization of nonvolatile memory for adjustment values			○
INFORMATION	C31	Display of microprocessor version, etc.		○	○
CPLAY1MODE	C34	Continuous playback mode		○	○
CREC 1MODE	C35	Continuous recording mode		○	○

- For details of each adjustment mode, refer to “5. Electrical Adjustments”.
For details of “Err Display”, refer to “Self-Diagnosis Function” on page 2.
- If a different mode has been selected by mistake, press the [MENU/NO] button to exit that mode.
- Modes with (X) in the Mark column are not used for servicing and therefore are not described in detail. If these modes are set accidentally, press the [MENU/NO] button to exit the mode immediately.

4-5-1. Operating the Continuous Playback Mode

1. Entering the continuous playback mode

- ① Set the disc in the unit. (Whichever recordable discs or discs for playback only are available.)
- ② Rotate the **[MD JOG]** knob and display “CPLAY1MODE” (C34).
- ③ Press the **[ENTER/YES]** button to change the display to “CPLAY1 MID”.
- ④ When access completes, the display changes to “C = [] AD = []”.

Note : The numbers “[]” displayed show you error rates and ADER.

2. Changing the parts to be played back

- ① Press the **[ENTER/YES]** button during continuous playback to change the display as below.

“CPLAY1 MID” → “CPLAY1 OUT” → “CPLAY1 IN”



When pressed another time, the parts to be played back can be moved.

- ② When access completes, the display changes to “C = [] AD = []”.

Note : The numbers “[]” displayed show you error rates and ADER.

3. Ending the continuous playback mode

- ① Press the **[MENU/NO]** button. The display will change to “CPLAY1MODE”(C34).
- ② Press the **[MD]** button to remove the disc.

Note : The playback start addresses for IN, MID, and OUT are as follows.

IN 40h cluster
MID 300h cluster
OUT 700h cluster

4-5-2. Operating the Continuous Recording Mode (Use only when performing self-recording/palyback check.)

1. Entering the continuous recording mode

- ① Set a recordable disc in the unit.
- ② Rotate the **[MD JOG]** knob and display “CREC 1MODE” (C35).
- ③ Press the **[ENTER/YES]** button to change the display to “CREC1 MID”.
- ④ When access completes, the display changes to “CREC1 ([])” and **REC** lights up.

Note : The numbers “[]” displayed shows you the recording position addresses.

2. Changing the parts to be recorded

- ① When the **[ENTER/YES]** button is pressed during continuous recording, the display changes as below.

“CREC1 MID” → “CREC1 OUT” → “CREC1 IN”

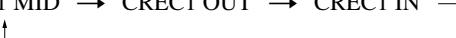

When pressed another time, the parts to be recorded can be changed. **REC** goes off.

- ② When access completes, the display changes to “CREC1 ([])” and **REC** lights up.

Note : The numbers “[]” displayed shows you the recording position addresses.

3. Ending the continuous recording mode

- ① Press the **[MENU/NO]** button. The display changes to “CREC 1MODE” (C35) and **REC** goes off.
- ② Press the **[MD]** button to remove the disc.

Note 1 : The recording start addresses for IN, MID, and OUT are as follows.

IN 40h cluster
MID 300h cluster
OUT 700h cluster

Note 2 : The **[MENU/NO]** button can be used to stop recording anytime.

Note 3 : Do not perform continuous recording for long periods of time above 5 minutes.

Note 4 : During continuous recording, be careful not to apply vibration.

4-6. FUNCTIONS OF OTHER BUTTONS

Function	Contents
ENTER/YES	Sets continuous playback when pressed in the STOP state. When pressed during continuous playback, the tracking servo turns ON/OFF.
□	Stops continuous playback and continuous recording.
▶▶ (MD JOG)	The sled moves to the outer circumference only when this is pressed.
◀◀ (MD JOG)	The sled moves to the inner circumference only when this is pressed.
REC MODE	Switches between the pit and groove modes when pressed.
REC	Switches the spindle servo mode (CLV S ↔ CLV A).
CLEAR	Switches the displayed contents each time the button is pressed.
⏏	Ejects the disc.
	Exits the test mode.

4-7. TEST MODE DISPLAYS

Each time the **MD DISPLAY** button is pressed, the display changes in the following order.

When CPLAY and CREC are started, the display will forcibly be switched to the error rate display as the initial mode.

1. Mode display

Displays “TEMP ADJUS” (C03), “CPLAY1MODE” (C34), etc.

2. Error rate display

Displays the error rate in the following way.

C1 = □□□□ AD = □□

C1 = Indicates the C1 error.

AD = Indicates ADER.

3. Address display

The address is displayed as follows. (MO:recordable disc, CD:playback only disc)

If the **CLEAR** button is pressed after pressing the **PROGRAM** button, the display switches from groove to pit or vice versa.

h = □□□□ s = □□□□ (MO pit and CD)

h = □□□□ a = □□□□ (MO groove)

h = Indicates the header address.

s = Indicates the SUBQ address.

a = Indicates the ADIP address.

Note: “-” is displayed when the address cannot be read.

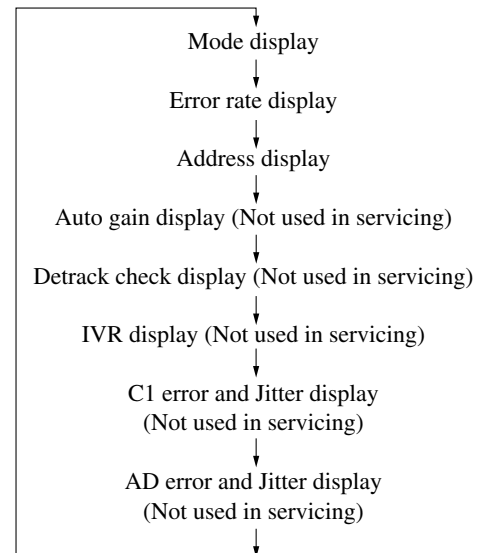

4-8. MEANINGS OF OTHER DISPLAYS

Display	Contents	
	When Lit	When Off
▷	Servo ON	Servo OFF
∞	Tracking servo OFF	Tracking servo ON
REC	Recording mode ON	Recording mode OFF
SYNC	CLV low speed mode	CLV normal mode
L.SYNC	ABCD adjustment completed	
OVER	Tracking offset cancel ON	Tracking offset cancel OFF
B/I	Tracking auto gain OK	
A-/REP	Focus auto gain OK	
TRACK/(LP) 4/Calendar frame	Pit	Groove
DISC/LP2	High reflection	Low reflection
SLEEP/SHUF	CLV S	CLV A
MONO	CLV LOCK	CLV UNLOCK

4-9. AUTOMATIC SELF-DIAGNOSIS FUNCTION

This test mode performs CREC and CPLAY automatically for mainly checking the characteristics of the optical pick-up.

To perform this test mode, the laser power must first be checked.

Perform AUTO CHECK after the laser power check and Iop check.

Procedure

1. Press the **ENTER/YES** button. If “LDPWR” is displayed, it means that the laser power check has not been performed. In this case, perform the laser power check and Iop compare, and then repeat from step 1.
2. If a disc is in the mechanical deck, it will be ejected forcibly.
“DISC IN” will be displayed in this case. Load a test disc (MDW-74/GA-1) which can be recorded.
3. If a disk is loaded at step 2, the check will start automatically.
4. When “XX CHECK” is displayed, the item corresponding to XX will be performed.
When “06 CHECK” completes, the disc loaded at step 2 will be ejected. “DISC IN” will be displayed. Load the check disc (MD) TDYS-1.
5. When the disc is loaded in step 4, the check will automatically be resumed from “07 CHECK”.
6. After completing to test item 12, check OK or NG will be displayed. If all items are OK, “CHECK ALL OK” will be displayed. If any item is NG, it will be displayed as “NG:xxxx”.

When “CHECK ALL OK” is displayed, it means that the optical pick-up is normal. Check the operations of the other spindle motor, thread motor, etc.

When displayed as “NG:xxxx”, it means that the optical pick-up is faulty. In this case, replace the optical pick-up.

4-10. INFORMATION

Display the software version.

Procedure

1. If displayed as “INFORMATION”, press the **ENTER/YES** button.
2. The software version will be displayed.
3. Press the **MENU/NO** button to end this mode.

4-11. WHEN MEMORY NG IS DISPLAYED

If the nonvolatile memory data is abnormal, “E001”/“MEMORY NG” will be displayed so that the MD deck does not continue operations. In this case, set the test mode promptly and perform the following procedure.

Procedure

1. Set the test mode. (Refer to 4-2.)
2. Normally a message for selecting the test mode will be displayed. However if the nonvolatile memory is abnormal, the following will be displayed. “INIT EEP?”
3. Press the **□** button and **△** button together.
4. Rotate the **MD JOG** knob and select MDM-7B.
5. Press the **MD JOG** knob. If the nonvolatile memory is successfully overwritten, the normal test mode will be set and a message to select the test mode will be displayed.

SECTION 5 ELECTRICAL ADJUSTMENTS

CD SECTION

Note:

1. CD Block is basically designed to operate without adjustment. Therefore, check each item in order given.
2. Use YEDS-18 disc (3-702-101-01) unless otherwise indicated.
3. Use an oscilloscope with more than 10 MΩ impedance.
4. Clean the object lens by an applicator with neutral detergent when the signal level is low than specified value with the following checks.
5. Use the following extension cables and relay connector.
 - Extension cable (19P) (Part No. J-2501-011-B)
 - Relay connector (Part No. J-2501-167-A)
 - (BD (CD) board CN101 to MAIN board CN111)
 - Extension cable (17P) (with connector) (Part No. J-2501-167-A)
 - (CONNECTOR board CN701 to MAIN board CN301)

1. S-CURVE CHECK

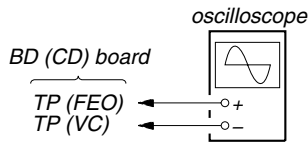

Procedure:

1. Connect oscilloscope to TP (FEO).
2. Connect between TP (FEO) and TP (VC) by lead wire.
3. Connect between TP (AGCCON) and TP (GND) by lead wire.
4. Turn the power ON.
5. Load a disc (YEDS-18) and turn the power ON again and actuate the focus search. (Actuate the focus search when disc tray is moving in and out)
6. Check the oscilloscope waveform (S-curve) is symmetrical between A and B. And confirm peak to peak level within 2.4 ± 0.7 Vp-p.

S-curve waveform

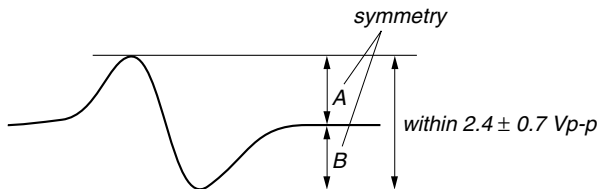

7. After check, remove the lead wire connected in step 2.

Note:

- Try to measure several times to make sure than the ratio of A : B or B : A is more than 10 : 7.
- Take sweep time as long as possible and light up the brightness to obtain best waveform.

2. RF LEVEL CHECK

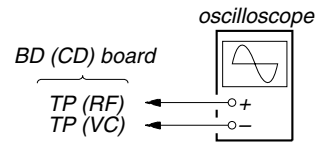

Procedure:

1. Connect oscilloscope to TP (RF).
As TP (RF) and TP (VC) are located at the edge of board, clip them together with the board using alligator clips.
2. Turn the power ON.
3. Load a disc (YEDS-18) and playback.
4. Confirm that oscilloscope waveform is clear and check RF signal level is correct or not.

Note: Clear RF signal waveform means that the shape “◇” can be clearly distinguished at the center of the waveform.

RF signal waveform

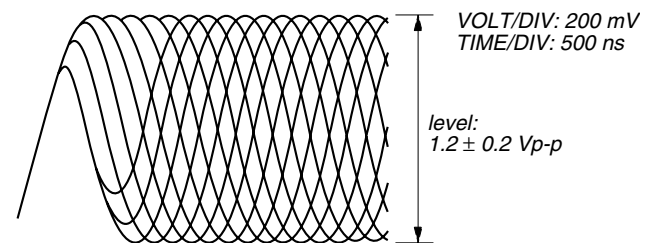

Connecting points :

[BD (CD) BOARD] — SIDE B —

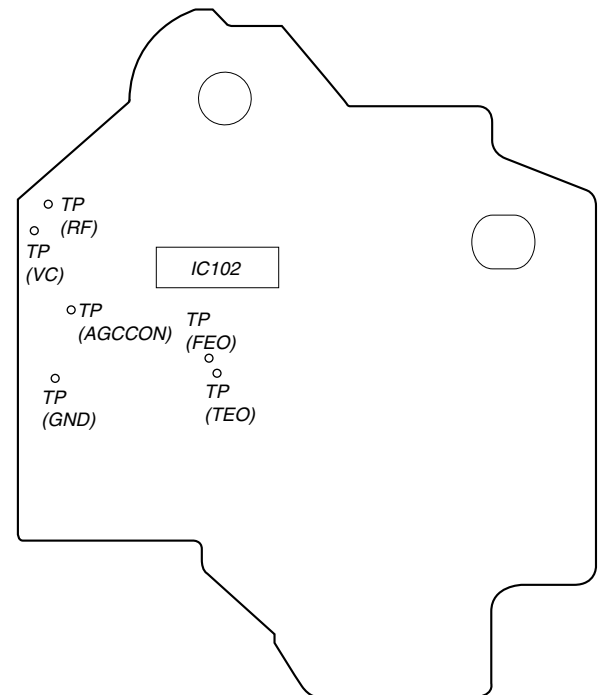

MD SECTION

5-1. PARTS REPLACEMENT AND ADJUSTMENT

If malfunctions caused by the optical pick-up such as sound skipping are suspected, follow the following check.

Check before replacement

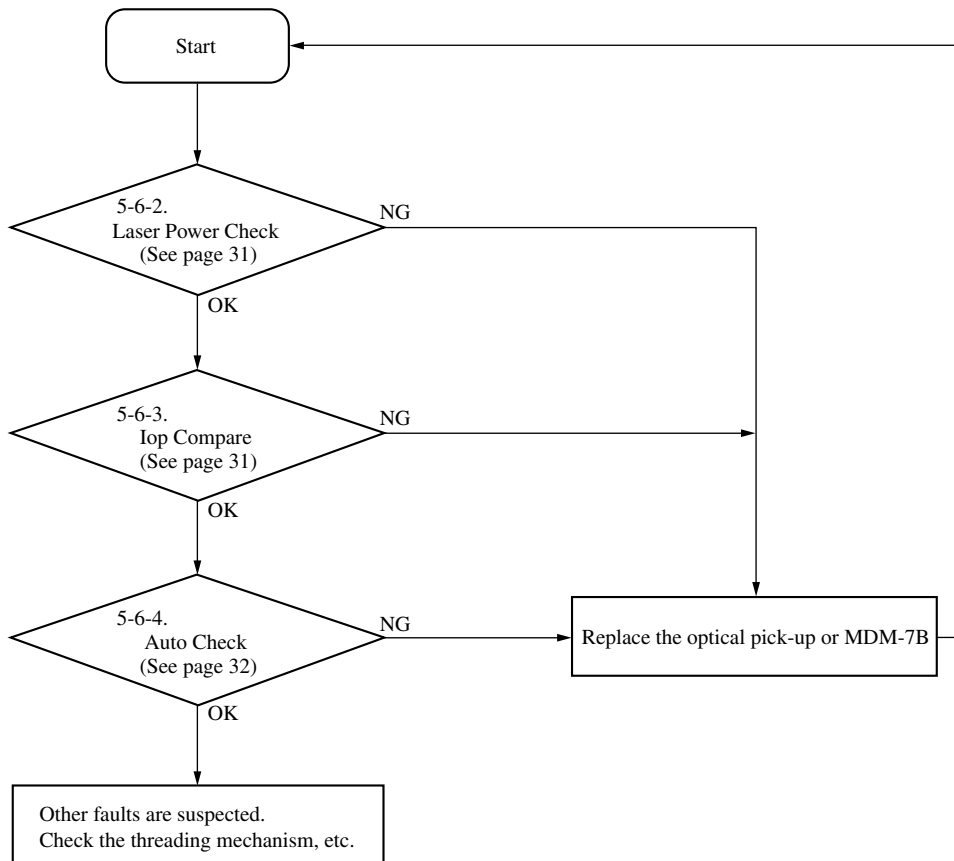

Adjustment flow

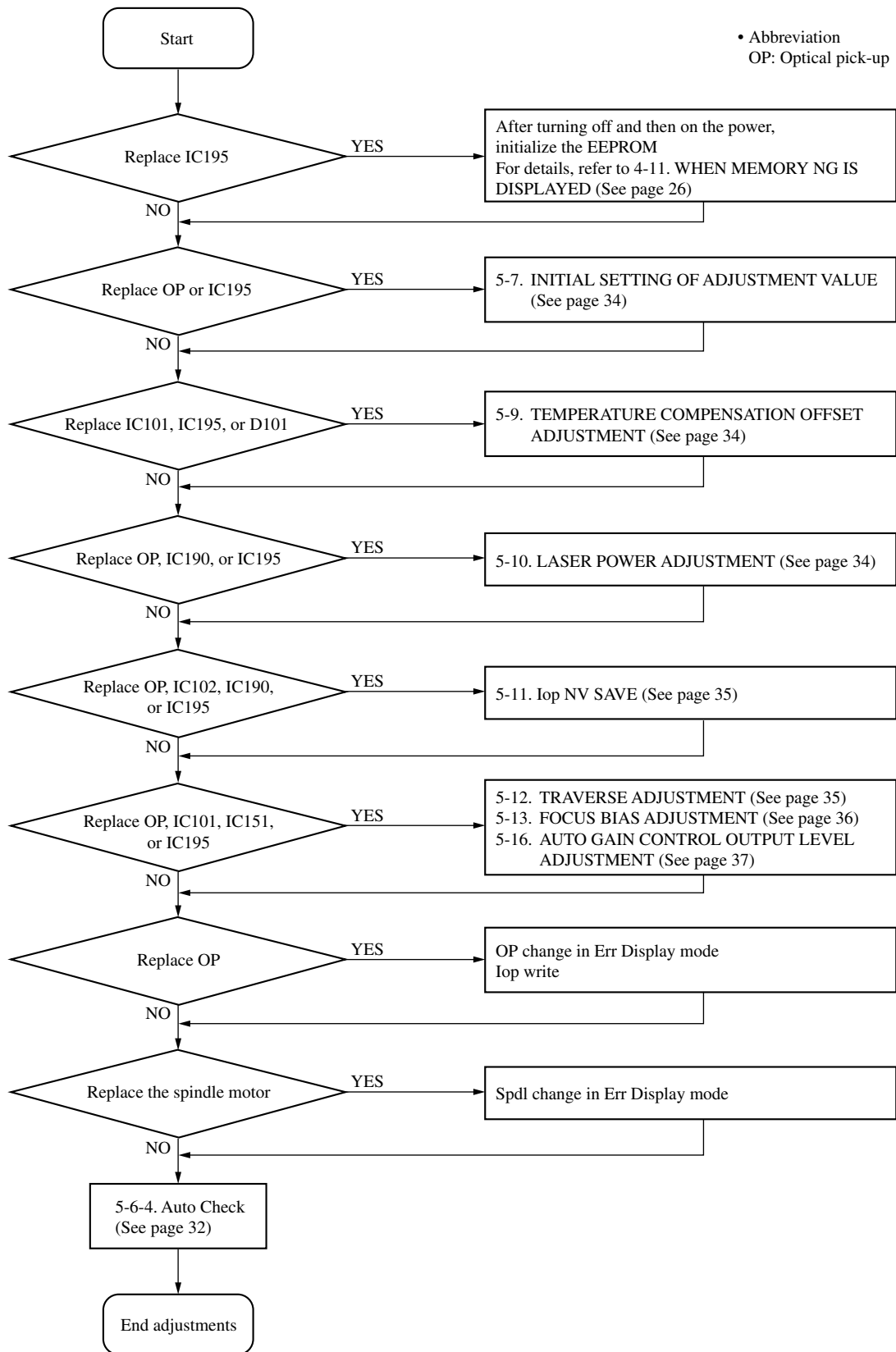

5-2. PRECAUTIONS FOR CHECKING LASER DIODE EMISSION

To check the emission of the laser diode during adjustments, never view directly from the top as this may lose your eye-sight.

5-3. PRECAUTIONS FOR USE OF OPTICAL PICK-UP (KMS-260B)

As the laser diode in the optical pick-up is easily damaged by static electricity, solder the laser tap of the flexible board when using it. Before disconnecting the connector, desolder first. Before connecting the connector, be careful not to remove the solder. Also take adequate measures to prevent damage by static electricity. Handle the flexible board with care as it breaks easily.

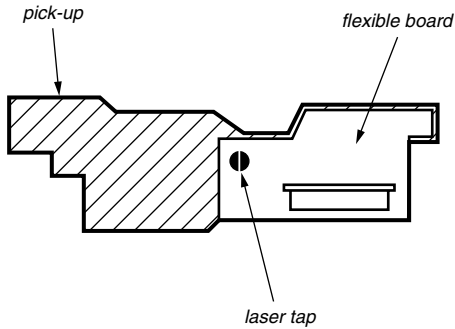

Optical pick-up flexible board

5-4. PRECAUTIONS FOR ADJUSTMENTS

- 1) When replacing the following parts, perform the adjustments and checks with ○ in the order shown in the following table.
- 2) Set the test mode when performing adjustments.
After completing the adjustments, exit the test mode.
Perform the adjustments and checks in “group S” of the test mode.
- 3) Perform the adjustments to be needed in the order shown.
- 4) Use the following tools and measuring devices.
 - Check Disc (MD) TDYS-1 (Parts No. 4-963-646-01)
 - Test Disk (MDW-74/GA-1) (Parts No. 4-229-747-01)
 - Laser power meter LPM-8001 (Parts No. J-2501-046-A)
or
 - MD Laser power meter 8010S (Parts No. J-2501-145-A)
 - Oscilloscope (Measure after performing CAL of prove.)
 - Digital voltmeter
 - Thermometer
 - Jig for checking BD board waveform (Parts No. : J-2501-196-A)
- 5) When observing several signals on the oscilloscope, etc., make sure that VC and ground do not connect inside the oscilloscope.
(VC and ground will become short-circuited.)
- 6) Using the above jig enables the waveform to be checked without the need to solder.
(Refer to Servicing Note on page 7.)
- 7) As the disc used will affect the adjustment results, make sure that no dusts nor fingerprints are attached to it.

Adjustment	Parts to be replaced						
	Optical Pick-up	IC101	IC102	IC151	IC190	IC195	D101
5-7. Initial setting of adjustment values	○	×	×	×	×	○	×
5-8. Recording of Iop information	○	×	×	×	×	○	×
5-9. TEMP ADJUST	×	○	×	×	×	○	○
5-10. Laser power adjustment	○	×	×	×	○	○	×
5-11. Iop NV Save	○	×	○	×	○	○	×
5-12. Traverse adjustment	○	○	×	○	×	○	×
5-13. Focus bias adjustment	○	○	×	○	×	○	×
5-16. Auto gain adjustment	○	○	×	○	×	○	×
5-6-4. AUTO CHECK	○	○	×	○	○	○	×

5-5. USING THE CONTINUOUSLY RECORDED DISC

- * This disc is used in focus bias adjustment and error rate check.
The following describes how to create a continuous recording disc.
1. Insert a disc (blank disc) commercially available.
 2. Rotate the **[MD JOG]** knob and display "CREC 1MODE" (C35).
 3. Press the **[ENTER/YES]** button again to display "CREC1 MID".
Display "CREC (0300)" and start to recording.
 4. Complete recording within 5 minutes.
 5. Press the **[MENU/NO]** button and stop recording .
 6. Press the **[EJECT]** button and remove the disc.

The above has been how to create a continuous recorded data for the focus bias adjustment and error rate check.

Note :

- Be careful not to apply vibration during continuous recording.

5-6. CHECKS PRIOR TO REPAIRS

These checks are performed before replacing parts according to "approximate specifications" to determine the faulty locations. For details, refer to "Checks Prior to Parts Replacement and Adjustments" (See page 9).

5-6-1. Temperature Compensation Offset Check

When performing adjustments, set the internal temperature and room temperature to 22 to 28°C.

Checks cannot be performed properly if performed after some time from power ON due to the rise in the temperature of the IC and diode, etc. So, perform the checks again after waiting some time.

Checking Procedure:

1. Rotate the **[MD JOG]** knob to display "TEMP CHECK" (C12).
2. Press the **[ENTER/YES]** button.
3. "T=@@ (##) [OK]" should be displayed. If "T=@@ (##) [NG]" is displayed, it means that the results are bad.
(@@ indicates the current value set, and ## indicates the value written in the non-volatile memory.)

5-6-2. Laser Power Check

Before checking, check the Iop value of the optical pick-up.
(Refer to 5-8. Recording and Displaying the Iop Information.)

Connection :

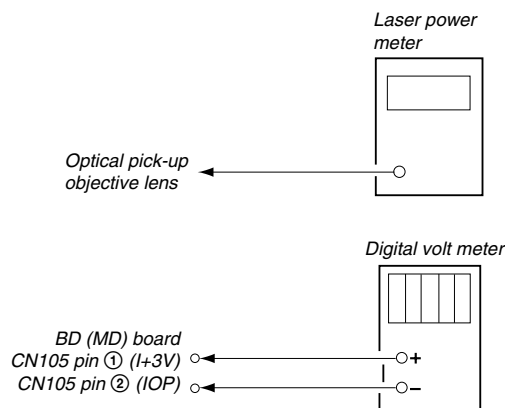

Checking Procedure:

1. Set the laser power meter on the objective lens of the optical pick-up. (When it cannot be set properly, press the **[◀]** button or **[▶]** button to move the optical pick-up.)
Connect the digital volt meter to CN105 pin ① (I+3V) and CN105 pin ② (IOP).
2. Then, rotate the **[MD JOG]** knob and display "LDPWR CHECK" (C13).
3. Press the **[ENTER/YES]** button once and display "LD 0.9 mW \$ []". Check that the reading of the laser power meter become 0.84 to 0.92 mW.
4. Press the **[ENTER/YES]** button once more and display "LD 7.0 mW \$ []". Check that the reading of the laser power meter and digital volt meter satisfy the specified value.

Specified Value :

Laser power meter reading : 7.0 ± 0.2 mW

Digital voltmeter reading : optical pick-up displayed value $\pm 10\%$

(Optical pick-up label)

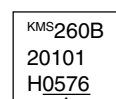

(For details of the method for checking this value, refer to "5-8. Recording and Displaying the Iop Information".)

Iop = 57.6 mA in this case

Iop (mA) = Digital voltmeter reading (mV)/1 (Ω)

5. Press the **[MENU/NO]** button and display "LDPWR CHECK" (C13) and stop the laser emission.
(The **[MENU/NO]** button is effective at all times to stop the laser emission.)

Note 1: After step 4, each time the **[ENTER/YES]** button is pressed, the display will be switched between "LD 0.7 mW \$ []", "LD 6.2 mW \$ []", and "LD Wp \$ []". Nothing needs to be performed here.

5-6-3. Iop Compare

The current Iop value at laser power 7 mw output and reference Iop value (set at shipment) written in the nonvolatile memory are compared, and the rate of increase/decrease will be displayed in percentage.

Note: Perform this function with the optical pick-up set at room temperature.

Procedure

1. Rotate the **[MD JOG]** knob to display "Iop Compare" (C27).
2. Press the **[ENTER/YES]** button and start measurements.
3. When measurements complete, the display changes to "±xx%yy".
xx is the percentage of increase/decrease, and OK or NG is displayed at yy to indicate whether the percentage of increase/decrease is within the allowable range.
4. Press the **[MENU/NO]** button to end.

5-6-4. Auto Check

This test mode performs CREC and CPLAY automatically for mainly checking the characteristics of the optical pick-up. To perform this test mode, the laser power must first be checked. Perform Auto Check after the laser power check and Top compare.

Procedure

1. Press the **ENTER/YES** button. If “LDPWR minicheck” is displayed, it means that the laser power check has not been performed. In this case, perform the laser power check and Top compare, and then repeat from step 1.
2. If a disc is in the mechanical deck, it will be ejected forcibly. “DISC IN” will be displayed in this case. Load a test disc (MDW-74/GA-1) which can be recorded.
3. If a disk is loaded at step 2, the check will start automatically.
4. When “XX CHECK” is displayed, the item corresponding to XX will be performed.
When “06 CHECK” completes, the disc loaded at step 2 will be ejected. “DISC IN” will be displayed. Load the check disc (MD) TDYS-1.
5. When the disc is loaded, the check will automatically be resumed from “07 CHECK”.
6. After completing to test item 12, check OK or NG will be displayed. If all items are OK, “CHECK ALL OK” will be displayed. If any item is NG, it will be displayed as “NG:xxxx”.

When “CHECK ALL OK” is displayed, it means that the optical pick-up is normal. Check the operations of the other spindle motor, thread motor, etc.

When displayed as “NG:xxxx”, it means that the optical pick-up is faulty. In this case, replace the optical pick-up.

5-6-5. Other Checks

All the following checks are performed by the Auto Check mode. They therefore need not be performed in normal operation.

5-6-6. Traverse Check

5-6-7. Focus Bias Check

5-6-8. C PLAY Check

5-6-9. Self-Recording/Playback Check

5-6-6. Traverse Check

Connection :

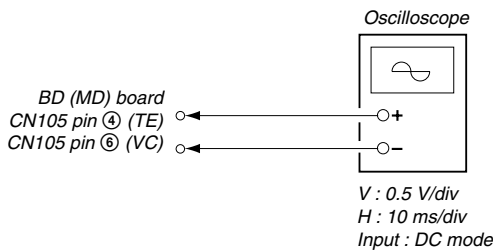

Checking Procedure:

1. Connect an oscilloscope to CN105 pin ④ (TE) and CN105 pin ⑥ (VC) of the BD (MD) board.
2. Load a test disc (MDW-74/GA-1). (Refer to Note 1.)
3. Press the **▶▶** button and move the optical pick-up outside the pit.
4. Rotate the **MD JOG** knob and display “EF MO CHECK” (C14).
5. Press the **ENTER/YES** button and display “EFB = **MO-R**”. (Laser power READ power/Focus servo ON/tracking servo OFF/spindle (S) servo ON)

6. Observe the waveform of the oscilloscope, and check that the specified value is satisfied. Do not rotate the **MD JOG** knob. (Read power traverse checking)

(Traverse Waveform)

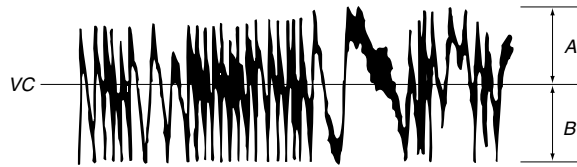

Specified value : Below 10% offset value

$$\text{Offset value (\%)} = \frac{|A - B|}{2(A + B)} \times 100$$

7. Press the **ENTER/YES** button and display “EFB = **MO-W**”.
8. Observe the waveform of the oscilloscope, and check that the specified value is satisfied. Do not rotate the **MD JOG** knob. (Write power traverse checking)

(Traverse Waveform)

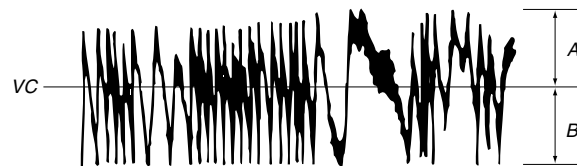

Specified value : Below 10% offset value

$$\text{Offset value (\%)} = \frac{|A - B|}{2(A + B)} \times 100$$

9. Press the **ENTER/YES** button display “EFB = **MO-P**”. Then, the optical pick-up moves to the pit area automatically and servo is imposed.
10. Observe the waveform of the oscilloscope, and check that the specified value is satisfied. Do not rotate the **MD JOG** knob.

(Traverse Waveform)

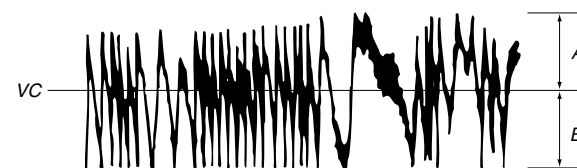

Specified value : Below 10% offset value

$$\text{Offset value (\%)} = \frac{|A - B|}{2(A + B)} \times 100$$

11. Press the **ENTER/YES** button display “EF MO CHECK” (C14). The disc stops rotating automatically.
12. Press the **⏏** button and remove the disc.
13. Load the check disc (MD) TDYS-1.
14. Rotate the **MD JOG** knob and display “EF CD CHECK” (C15).
15. Press the **ENTER/YES** button and display “EFB = **CD**”. Servo is imposed automatically.

- Observe the waveform of the oscilloscope, and check that the specified value is satisfied. Do not rotate the **[MD JOG]** knob.

(Traverse Waveform)

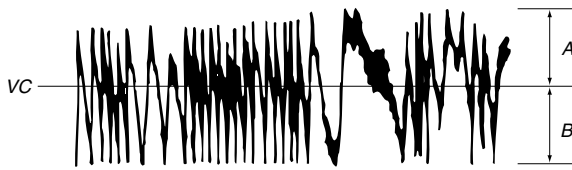

Specified value : Below 10% offset value

$$\text{Offset value (\%)} = \frac{|A - B|}{2(A + B)} \times 100$$

- Press the **[ENTER/YES]** button and display “EF CD CHECK” (C15).
- Press the **[⇐]** button and remove the check disc (MD) TDYS-1.

Note 1 : MO reading data will be erased during if a recorded disc is used in this adjustment.

Note 2 : If the traverse waveform is not clear, connect the oscilloscope as shown in the following figure so that it can be seen more clearly.

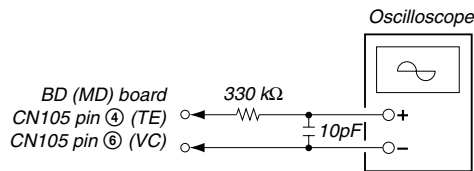

5-6-7. Focus Bias Check

Change the focus bias and check the focus tolerance amount.

Checking Procedure :

- Load a continuously recorded test disc (MDW-74/GA-1). (Refer to “5-5. Using the Continuously Recorded Disc”.)
- Rotate the **[MD JOG]** knob and display “CPLAY 1MODE” (C34).
- Press the **[ENTER/YES]** button and display “CPLAY1 MID”.
- Press the **[MENU/NO]** button when “C = [] AD = []” is displayed.
- Rotate the **[MD JOG]** knob and display “FBIAS CHECK” (C16).
- Press the **[ENTER/YES]** button and display “[]/[] c = []”.
The first four digits indicate the C1 error rate, the two digits after [/] indicate ADER, and the 2 digits after [c =] indicate the focus bias value.
Check that the C1 error is below 20 and ADER is below 2.
- Press the **[ENTER/YES]** button and display “[]/[] b = []”.
Check that the C1 error is below 100 and ADER is below 2.
- Press the **[ENTER/YES]** button and display “[]/[] a = []”.
Check that the C1 error is below 100 and ADER is below 2.
- Press the **[MENU/NO]** button, next press the **[⇐]** button, and remove the test disc.

5-6-8. C PLAY Check

MO Error Rate Check

Checking Procedure :

- Load a continuously recorded test disc (MDW-74/GA-1). (Refer to “5-5. Using the Continuously Recorded Disc”.)
- Rotate the **[MD JOG]** knob and display “CPLAY 1MODE” (C34).
- Press the **[ENTER/YES]** button and display “CPLAY1 MID”.
- The display changes to “C1 = [] AD = []”.
- If the C1 error rate is below 20, check that ADER is 00.
- Press the **[MENU/NO]** button, stop playback, press the **[⇐]** button, and test disc.

CD Error Rate Check

Checking Procedure :

- Load a check disc (MD) TDYS-1.
- Rotate the **[MD JOG]** knob and display “CPLAY 1MODE” (C34).
- Press the **[ENTER/YES]** button twice and display “CPLAY1 MID”.
- The display changes to “C1 = [] AD = []”.
- Check that the C1 error rate is below 20.
- Press the **[MENU/NO]** button, stop playback, press the **[⇐]** button, and the test disc.

5-6-9. Self-Recording/playback Check

Prepare a continuous recording disc using the unit to be repaired and check the error rate.

Checking Procedure :

- Insert a recordable test disc (MDW-74/GA-1) into the unit.
- Rotate the **[MD JOG]** knob to display “CREC 1MODE” (C35).
- Press the **[ENTER/YES]** button to display the “CREC1 MID”.
- When recording starts, “**REC**” is displayed, this becomes “CREC (@@@@)” (@@@@ is the address), and recording starts.
- About 1 minute later, press the **[MENU/NO]** button to stop continuous recording.
- Rotate the **[MD JOG]** knob to display “CPLAY 1MODE” (C34).
- Press the **[ENTER/YES]** button to display “C PLAY1 MID”.
- “C1 = [] AD = []” will be displayed.
- Check that the C1 error becomes below 20 and the AD error below 2.
- Press the **[MENU/NO]** button to stop playback, and press the **[⇐]** button and remove the disc.

5-7. INITIAL SETTING OF ADJUSTMENT VALUE

Note:

Mode which sets the adjustment results recorded in the non-volatile memory to the initial setting value. However the results of the temperature compensation offset adjustment will not change to the initial setting value.

If initial setting is performed, perform all adjustments again excluding the temperature compensation offset adjustment.

For details of the initial setting, refer to “5-4. Precautions for Adjustments” and execute the initial setting before the adjustment as required.

Setting Procedure :

1. Rotate the **[MD JOG]** knob to display “ADJ CLEAR” (C28).
2. Press the **[ENTER/YES]** button. “Complete!” will be displayed momentarily and initial setting will be executed, after which “ADJ CLEAR” (C28) will be displayed.

5-8. RECORDING AND DISPLAYING THE Iop INFORMATION

The IOP data can be recorded in the non-volatile memory. The Iop value on the label of the optical pick-up and the Iop value after the adjustment will be recorded. Recording these data eliminates the need to read the label on the optical pick-up.

Recording Procedure :

1. While pressing the **[MD JOG]** knob and **[]** button, connect the power plug to the outlet, and release the **[MD JOG]** knob and **[]** button.
2. Rotate the **[MD JOG]** knob to display “[Service]”, and press the **[ENTER/YES]** button.
3. Rotate the **[MD JOG]** knob to display “Iop Write” (C05), and press the **[ENTER/YES]** button.
4. The display becomes Ref=@@.@ (@ is an arbitrary number) and the numbers which can be changed will blink.
5. Input the Iop value written on the optical pick-up.
To select the number : Rotate the **[MD JOG]** knob.
To select the digit : Press the **[MD JOG]** knob
6. When the **[ENTER/YES]** button is pressed, the display becomes “Meas=@@.@” (@ is an arbitrary number).
7. As the adjustment results are recorded for the 6 value. Leave it as it is and press the **[ENTER/YES]** button.
8. “Complete!” will be displayed momentarily. The value will be recorded in the non-volatile memory and the display will become “Iop Write” (C05).

Display Procedure :

1. Rotate the **[MD JOG]** knob to display “Iop Read” (C26).
2. “@@.@/##.#” is displayed and the recorded contents are displayed.
@@.@ indicates the Iop value labeled on the optical pick-up.
##.# indicates the Iop value after adjustment
3. To end, press the **[MD JOG]** button or **[MENU/NO]** button to display “Iop Read” (C26).

5-9. TEMPERATURE COMPENSATION OFFSET ADJUSTMENT

Save the temperature data at that time in the non-volatile memory as 25 °C reference data.

Note :

1. Usually, do not perform this adjustment.
2. Perform this adjustment in an ambient temperature of 22 °C to 28 °C. Perform it immediately after the power is turned on when the internal temperature of the unit is the same as the ambient temperature of 22 °C to 28 °C.
3. When D101 has been replaced, perform this adjustment after the temperature of this part has become the ambient temperature.

Adjusting Procedure :

1. Rotate the **[MD JOG]** knob and display “TEMP ADJUS” (C03).
2. Press the **[ENTER/YES]** button and select the “TEMP ADJUS” (C03) mode.
3. “TEMP = [] [OK]” and the current temperature data will be displayed.
4. To save the data, press the **[ENTER/YES]** button.
When not saving the data, press the **[MENU/NO]** button.
5. When the **[ENTER/YES]** button is pressed, “TEMP = [] SAVE” will be displayed and turned back to “TEMP ADJUS” (C03) display then. When the **[MENU/NO]** button is pressed, “TEMP ADJUS” (C03) will be displayed immediately.

Specified Value :

The “TEMP = []” should be within “E0 - EF”, “F0 - FF”, “00 - 0F”, “10 - 1F” and “20 - 2F”.

5-10. LASER POWER ADJUSTMENT

Check the Iop value of the optical pick-up before adjustments. (Refer to 5-8. Recording and Displaying the Iop Information.)

Connection :

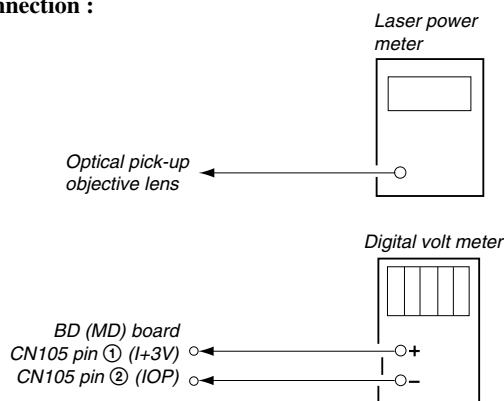

Adjusting Procedure :

1. Set the laser power meter on the objective lens of the optical pick-up. (When it cannot be set properly, press the **[◀]** button or **[▶]** button to move the optical pick-up.)
Connect the digital volt meter to CN105 pin ① (I+3V) and CN105 pin ② (IOP).
2. Rotate the **[MD JOG]** knob and display “LDPWR ADJUS” (C04). (Laser power : For adjustment)
3. Press the **[ENTER/YES]** button once and display “LD 0.9 mW \$ []”.
4. Rotate the **[MD JOG]** knob so that the reading of the laser power meter becomes 0.85 to 0.91 mW. Press the **[ENTER/YES]** button after setting the range knob of the laser power meter, and save the adjustment results. (“LD SAVE \$ []” will be displayed for a moment.)
5. Then “LD 7.0 mW \$ []” will be displayed.
6. Rotate the **[MD JOG]** knob so that the reading of the laser power meter becomes 6.9 to 7.1 mW, press the **[ENTER/YES]** button and save it.

Note : Do not perform the emission with 7.0 mW more than 15 seconds continuously.

- Then, rotate the **MD JOG** knob and display “LDPWR CHECK” (C13).
- Press the **ENTER/YES** button once and display “LD 0.9 mW \$ ”. Check that the reading of the laser power meter become 0.85 to 0.91 mW.
- Press the **ENTER/YES** button once more and display “LD 7.0 mW \$ ”. Check that the reading the laser power meter and digital volt meter satisfy the specified value.
Note down the digital voltmeter reading value.

Specified Value :

Laser power meter reading : 7.0 ± 0.2 mW

Digital voltmeter reading : optical pick-up displayed value $\pm 10\%$

(Optical pick-up label)

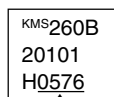

(For details of the method for checking this value, refer to “5-8. Recording and Displaying the IOP Information.”)

$I_{op} = 57.6$ mA in this case
 $I_{op} \text{ (mA)} = \text{Digital voltmeter reading (mV)} / 1 (\Omega)$

- Press the **MENU/NO** button and display “LDPWR CHECK” (C13) and stop the laser emission.
(The **MENU/NO** button is effective at all times to stop the laser emission.)
- Rotate the **MD JOG** knob to display “Iop Write” (C05).
- Press the **ENTER/YES** button. When the display becomes Ref=@@@@ (@ is an arbitrary number), press the **ENTER/YES** button to display “Meas=@@@@” (@ is an arbitrary number).
- The numbers which can be changed will blink. Input the Iop value noted down at step 9.
To select the number : Rotate the **MD JOG** knob.
To select the digit : Press the **MD JOG** knob
- When the **ENTER/YES** button is pressed, “Complete!” will be displayed momentarily. The value will be recorded in the non-volatile memory and the display will become “Iop Write” (C05).

Note 1: After step 4, each time the **ENTER/YES** button is pressed, the display will be switched between “LD 0.7 mW \$ ”, “LD 6.2 mW \$ ”, and “LD Wp \$ ”. Nothing needs to be performed here.

5-11. Iop NV SAVE

Write the reference values in the nonvolatile memory to perform “Iop compare”. As this involves rewriting the reference values, do not perform this procedure except when adjusting the laser power during replacement of the optical pick-up and when replacing the IC102. Otherwise the optical pick-up check may deteriorate.

Note: Perform this function with the optical pick-up set at room temperature.

Procedure

- Rotate the **MD JOG** knob to display “Iop NV Save” (C06).
- Press the **ENTER/YES** button and display “Iop [stop]”.
- After the display changes to “Iop =xxsave?”, press the **ENTER/YES** button.
- After “Complete!” is displayed momentarily, the display changes to “Iop 7.0 mW”.
- After the display changes to “Iop=yysave?”, press the **ENTER/YES** button.
- When “Complete!” is displayed, it means that Iop NV saving has been completed.

5-12. TRAVERSE ADJUSTMENT

Connection :

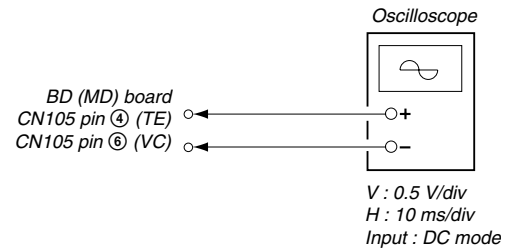

Adjusting Procedure :

- Connect an oscilloscope to CN105 pin ④ (TE) and CN105 pin ⑥ (VC) of the BD board.
- Load a test disc (MDW-74/GA-1). (Refer to Note 1.)
- Press the **▶▶** button and move the optical pick-up outside the pit.
- Rotate the **MD JOG** knob and display “EF MO ADJUS” (C14).
- Press the **ENTER/YES** button and display “EFB = MO-R”. (Laser power READ power/Focus servo ON/tracking servo OFF/spindle (S) servo ON)
- Rotate the **MD JOG** knob so that the waveform of the oscilloscope becomes the specified value.
(When the **MD JOG** knob is rotated, the of “EFB= ” changes and the waveform changes.) In this adjustment, waveform varies at intervals of approx. 2%. Adjust the waveform so that the specified value is satisfied as much as possible.
(Read power traverse adjustment)

(Traverse Waveform)

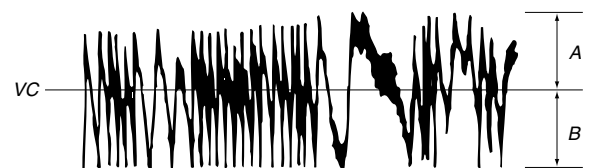

Specification A = B

- Press the **ENTER/YES** button and save the result of adjustment to the non-volatile memory (“EFB = SAVE” will be displayed for a moment. Then “EFB = MO-W” will be displayed).
- Rotate the **MD JOG** knob so that the waveform of the oscilloscope becomes the specified value.
(When the **MD JOG** knob is rotated, the of “EFB= MO-W” changes and the waveform changes.) In this adjustment, waveform varies at intervals of approx. 2%. Adjust the waveform so that the specified value is satisfied as much as possible.
(Write power traverse adjustment)

(Traverse Waveform)

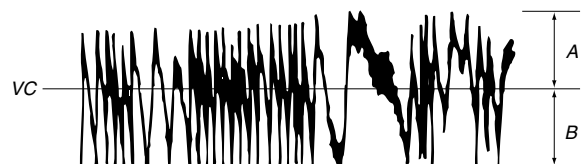

Specification A = B

- Press the **ENTER/YES** button, and save the adjustment results in the non-volatile memory. (“EFB = SAVE” will be displayed for a moment.)
- “EFB = MO-P”. will be displayed.
The optical pick-up moves to the pit area automatically and servo is imposed.

- Rotate the **[MD JOG]** knob until the waveform of the oscilloscope moves closer to the specified value.
In this adjustment, waveform varies at intervals of approx. 2%. Adjust the waveform so that the specified value is satisfied as much as possible.

(Traverse Waveform)

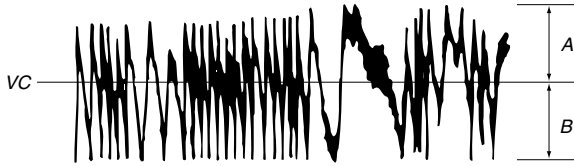

Specification $A = B$

- Press the **[ENTER/YES]** button, and save the adjustment results in the non-volatile memory. (“EFB = $\square\square$ SAVE” will be displayed for a moment.)
Next “EF MO ADJUS” (C07) is displayed. The disc stops rotating automatically.
- Press the **[\square]** button and remove the disc.
- Load the check disc (MD) TDYS-1.
- Rotate **[MD JOG]** knob and display “EF CD ADJUS” (C08).
- Press the **[ENTER/YES]** button and display “EFB = $\square\square$ CD”. Servo is imposed automatically.
- Rotate the **[MD JOG]** knob so that the waveform of the oscilloscope moves closer to the specified value.
In this adjustment, waveform varies at intervals of approx. 2%. Adjust the waveform so that the specified value is satisfied as much as possible.

(Traverse Waveform)

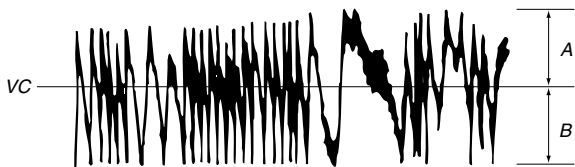

Specification $A = B$

- Press the **[ENTER/YES]** button, display “EFB = $\square\square$ SAVE” for a moment and save the adjustment results in the non-volatile memory.
Next “EF CD ADJUS” (C08) will be displayed.
- Press the **[\square]** button and remove the check disc (MD) TDYS-1.

Note 1 : MO reading data will be erased during if a recorded disc is used in this adjustment.

Note 2 : If the traverse waveform is not clear, connect the oscilloscope as shown in the following figure so that it can be seen more clearly.

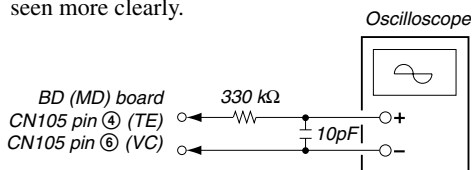

5-13. FOCUS BIAS ADJUSTMENT

Adjusting Procedure :

- Load a test disk (MDW-74/GA-1).
- Rotate the **[MD JOG]** knob and display “CPLAY1MODE” (C34).
- Press the **[ENTER/YES]** button and display “CPLAY1 MID”.
- Press the **[MENU/NO]** button when “C1 = $\square\square\square\square$ AD = $\square\square$ ” is displayed.
- Rotate the **[MD JOG]** knob and display “FBIAS ADJUS” (C09).
- Press the **[ENTER/YES]** button and display “ $\square\square\square\square$ / $\square\square$ a = $\square\square$ ”.
The first four digits indicate the C1 error rate, the two digits after [/] indicate ADER, and the 2 digits after [a =] indicate the focus bias value.
- Rotate the **[MD JOG]** knob in the clockwise direction and find the focus bias value at which the C1 error rate becomes 220 (Refer to Note 2).
- Press the **[ENTER/YES]** button and display “ $\square\square\square\square$ / $\square\square$ b = $\square\square$ ”.
- Rotate the **[MD JOG]** knob in the counterclockwise direction and find the focus bias value at which the C1 error rate becomes 220.
- Press the **[ENTER/YES]** button and display “ $\square\square\square\square$ / $\square\square$ c = $\square\square$ ”.
- Check that the C1 error rate is below 20 and ADER is 00. Then press the **[ENTER/YES]** button.
- If the “(00” in “ $\square\square$ - $\square\square$ - $\square\square$ (00” is above 20, press the **[ENTER/YES]** button.
If below 20, press the **[MENU/NO]** button and repeat the adjustment from step 2.
- Press the **[\square]** button to remove the test disc.

Note 1 : The relation between the C1 error and focus bias is as shown in the following figure. Find points a and b in the following figure using the above adjustment. The focal point position C is automatically calculated from points a and b.

Note 2 : As the C1 error rate changes, perform the adjustment using the average value.

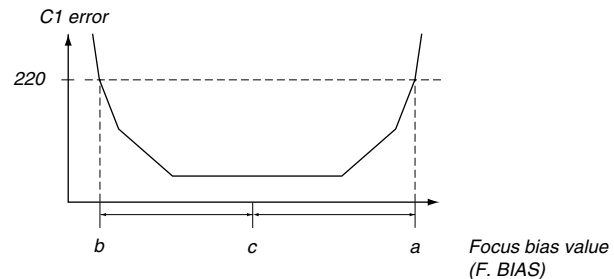

5-14. ERROR RATE CHECK

5-14-1. CD Error Rate Check

Checking Procedure :

1. Load a check disc (MD) TDYS-1.
2. Rotate the **[MD JOG]** knob and display "CPLAY1MODE" (C34).
3. Press the **[ENTER/YES]** button twice and display "CPLAY1 MID".
4. The display changes to "C1 = [] [] [] [] AD = [] []".
5. Check that the C1 error rate is below 20.
6. Press the **[MENU/NO]** button, stop playback, press the **[]** button, and remove the test disc.

5-14-2. MO Error Rate Check

Checking Procedure :

1. Load a continuously recorded test disc (MDW-74/GA-1). (Refer to "5-5. Using the Continuously Recorded Disc".)
2. Rotate the **[MD JOG]** knob and display "CPLAY1MODE" (C34).
3. Press the **[ENTER/YES]** button and display "CPLAY1 MID".
4. The display changes to "C1 = [] [] [] [] AD = [] []".
5. If the C1 error rate is below 20, check that ADER is 00.
6. Press the **[MENU/NO]** button, stop playback, press the **[]** button, and remove the test disc.

5-15. FOCUS BIAS CHECK

Change the focus bias and check the focus tolerance amount.

Checking Procedure :

1. Load a continuously recorded test disc (MDW-74/GA-1). (Refer to "5-5. Using the Continuously Recorded Disc".)
2. Rotate the **[MD JOG]** knob and display "CPLAY1MODE" (C34).
3. Press the **[ENTER/YES]** button twice and display "CPLAY1 MID".
4. Press the **[MENU/NO]** button when "C1 = [] [] [] [] AD = [] []" is displayed.
5. Rotate the **[MD JOG]** knob and display "FBIAS CHECK" (C16).
6. Press the **[ENTER/YES]** button and display "[] [] [] [] / [] [] c = [] []".
The first four digits indicate the C1 error rate, the two digits after [/] indicate ADR, and the 2 digits after [c =] indicate the focus bias value.
Check that the C1 error is below 20 and ADER is below 2.
7. Press the **[ENTER/YES]** button and display "[] [] [] [] / [] [] b = [] []".
Check that the C1 error is below 100 and ADER is below 2.
8. Press the **[ENTER/YES]** button and display "[] [] [] [] / [] [] a = [] []".
Check that the C1 error is below 100 and ADER is below 2.
9. Press the **[MENU/NO]** button, next press the **[]** button, and remove the continuously recorded disc.

Note 1 : If the C1 error and ADER are above other than the specified value at points a (step 8. in the above) or b (step 7. in the above), the focus bias adjustment may not have been carried out properly. Adjust perform the beginning again.

5-16. AUTO GAIN CONTROL OUTPUT LEVEL ADJUSTMENT

Be sure to perform this adjustment when the optical pick-up is replaced.

If the adjustment results becomes "Adjust NG!", the optical pick-up may be faulty or the servo system circuits may be abnormal.

5-16-1. CD Auto Gain Control Output Level Adjustment

Adjusting Procedure :

1. Insert the check disc (MD) TDYS-1.
2. Rotate the **[MD JOG]** knob to display "AG Set (CD)" (C11).
3. When the **[ENTER/YES]** button is pressed, the adjustment will be performed automatically.
"Complete!" will then be displayed momentarily when the value is recorded in the non-volatile memory, after which the display changes to "AG Set (CD)" (C11).
4. Press the **[]** button to remove the disc.

5-16-2. MO Auto Gain Control Output Level Adjustment

Adjusting Procedure :

1. Insert the reference disc (MDW-74/GA-1) for recording.
2. Rotate the **[MD JOG]** knob to display "AG Set (MO)" (C10).
3. When the **[ENTER/YES]** button is pressed, the adjustment will be performed automatically.
"Complete!" will then be displayed momentarily when the value is recorded in the non-volatile memory, after which the display changes to "AG Set (MO)" (C10).
4. Press the **[]** button to remove the disc.

5-17. ADJUSTING POINTS AND CONNECTING POINTS

[BD (MD) BOARD] (SIDE A)

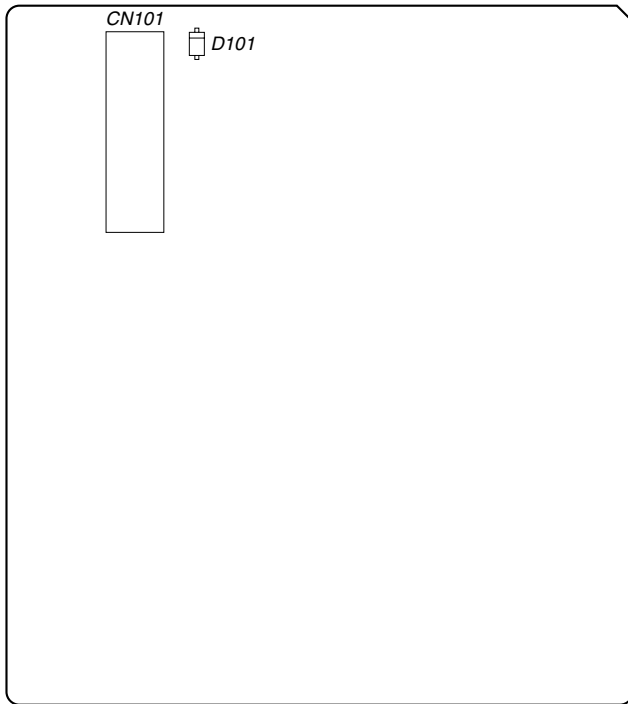

[BD (MD) BOARD] (SIDE B)

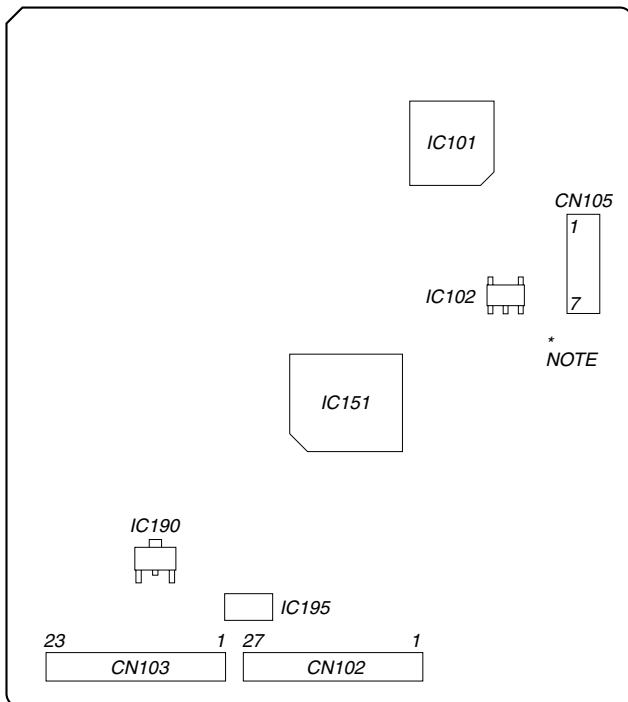

NOTE: It is useful to use the jig for checking the waveform. (Refer to Servicing Note on page 7.)

SECTION 6 DIAGRAMS

6-1. CIRCUIT BOARDS LOCATION

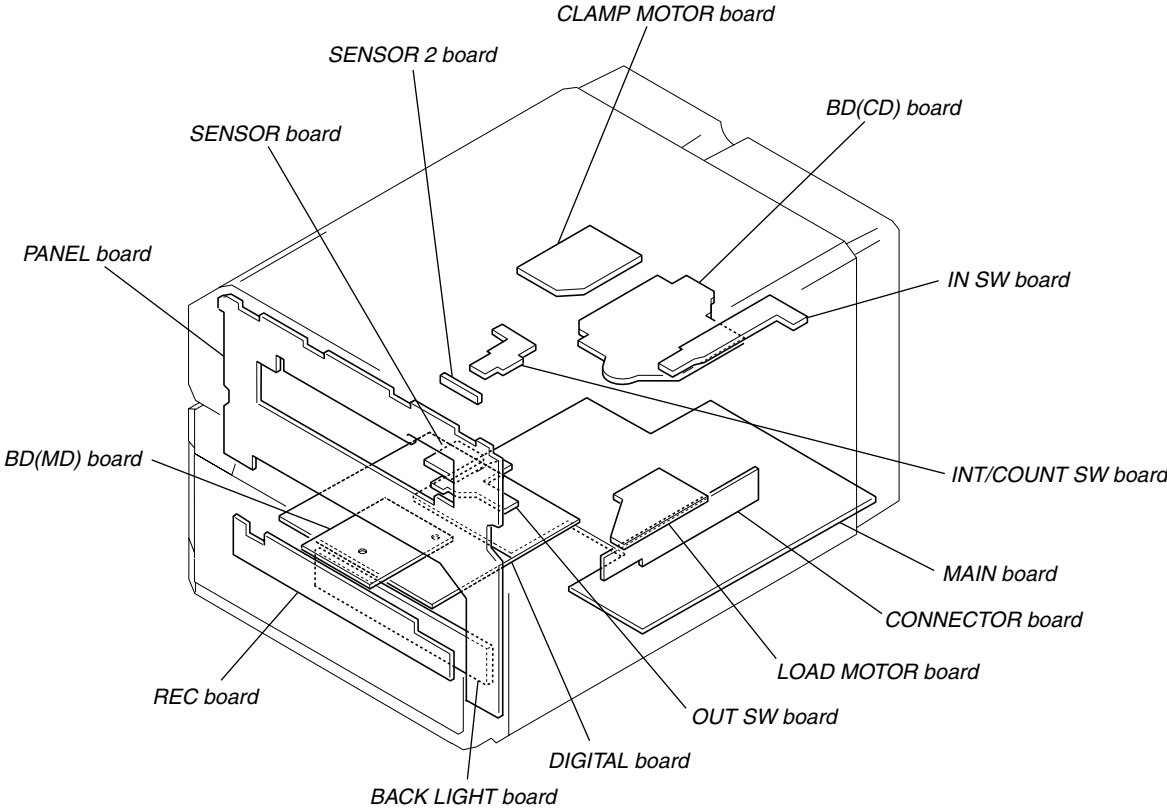



THIS NOTE IS COMMON FOR PRINTED WIRING BOARDS AND SCHEMATIC DIAGRAMS.









(In addition to this, the necessary note is printed in each block.)

For schematic diagrams.

Note:





- All capacitors are in μF unless otherwise noted. pF: $\mu\mu\text{F}$ 50 WV or less are not indicated except for electrolytics and tantalums.
- All resistors are in Ω and $1/4\text{ W}$ or less unless otherwise specified.
- \triangle : internal component.
-  : nonflammable resistor.
-  : panel designation.

Note: The components identified by mark \triangle or dotted line with mark \triangle are critical for safety.
Replace only with part number specified.

-  : B+ Line.
-  : B- Line.
-  : adjustment for repair.
- Voltages and waveforms are dc with respect to ground under no-signal (detuned) conditions.
- Voltages are taken with a VOM (Input impedance $10\text{ M}\Omega$). Voltage variations may be noted due to normal production tolerances.
- Waveforms are taken with a oscilloscope. Voltage variations may be noted due to normal production tolerances.
- Circled numbers refer to waveforms.
- Signal path.
 -  : CD PLAY
 -  : CD PLAY (Digital)
 -  : MD PLAY
 -  : MD PLAY (Digital)
 -  : RECORD
 -  : RECORD (Digital)
- Abbreviation
 - G : German model
 - AED : North European model
 - SP : Singapore model
 - MY : Malaysia model

For printed wiring boards.

Note:

-  : parts extracted from the component side.
 -  : parts extracted from the conductor side.
 -  : Through hole.
 -  : Pattern from the side which enables seeing.
- (The other layers' patterns are not indicated.)

Caution:
 Pattern face side: Parts on the pattern face side seen from the (Side B) pattern face are indicated.
 Parts face side: Parts on the parts face side seen from the (Side A) parts face are indicated.

• Indication of transistor

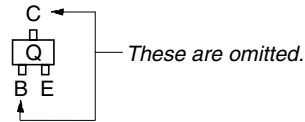
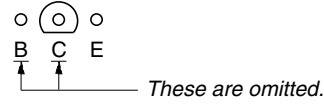
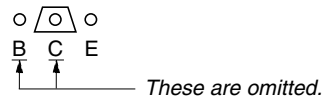

6-2. BLOCK DIAGRAMS
- CD SECTION -

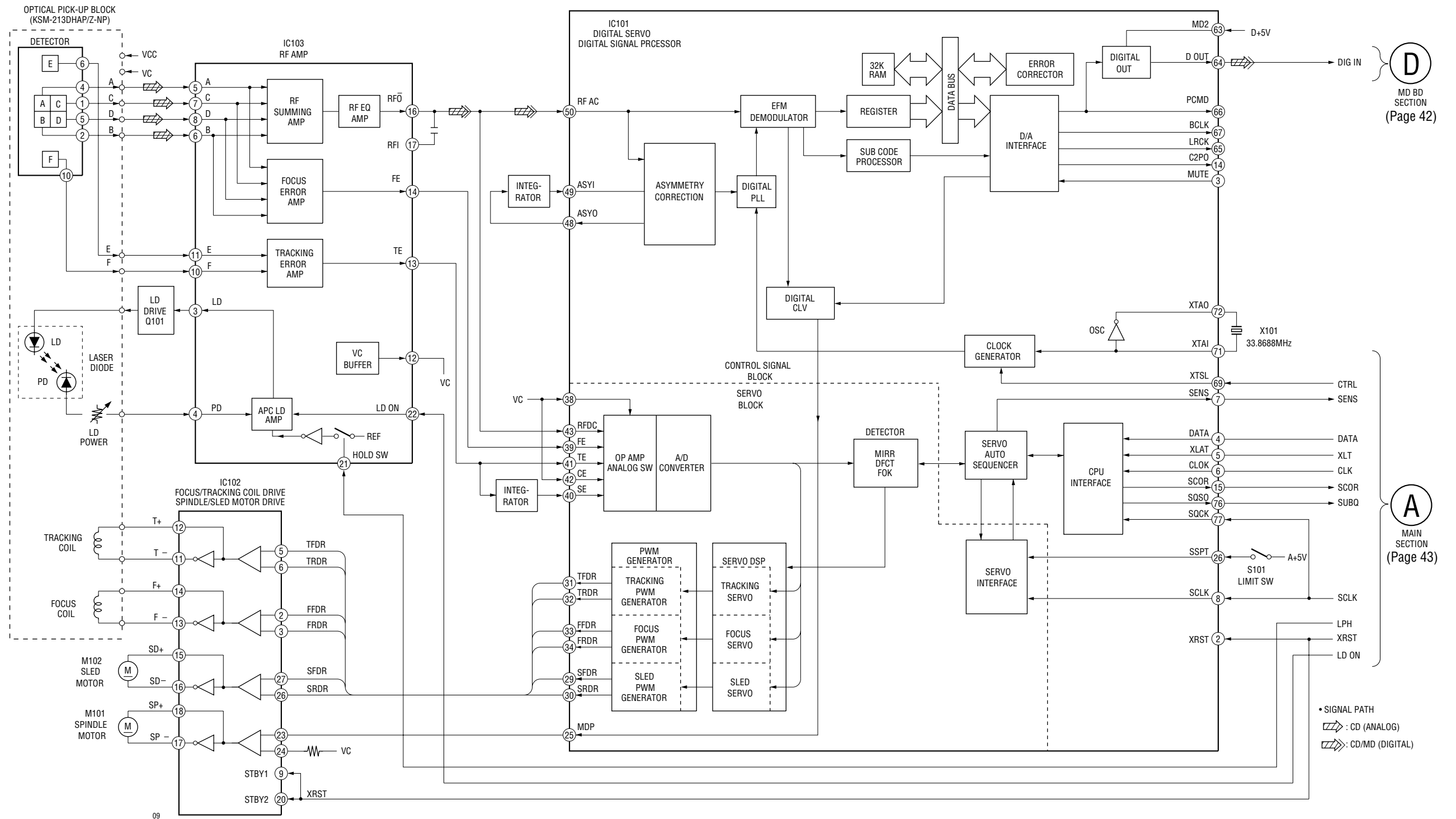

D
MD BD
SECTION
(Page 42)

A
MAIN
SECTION
(Page 43)

- MD SECTION -

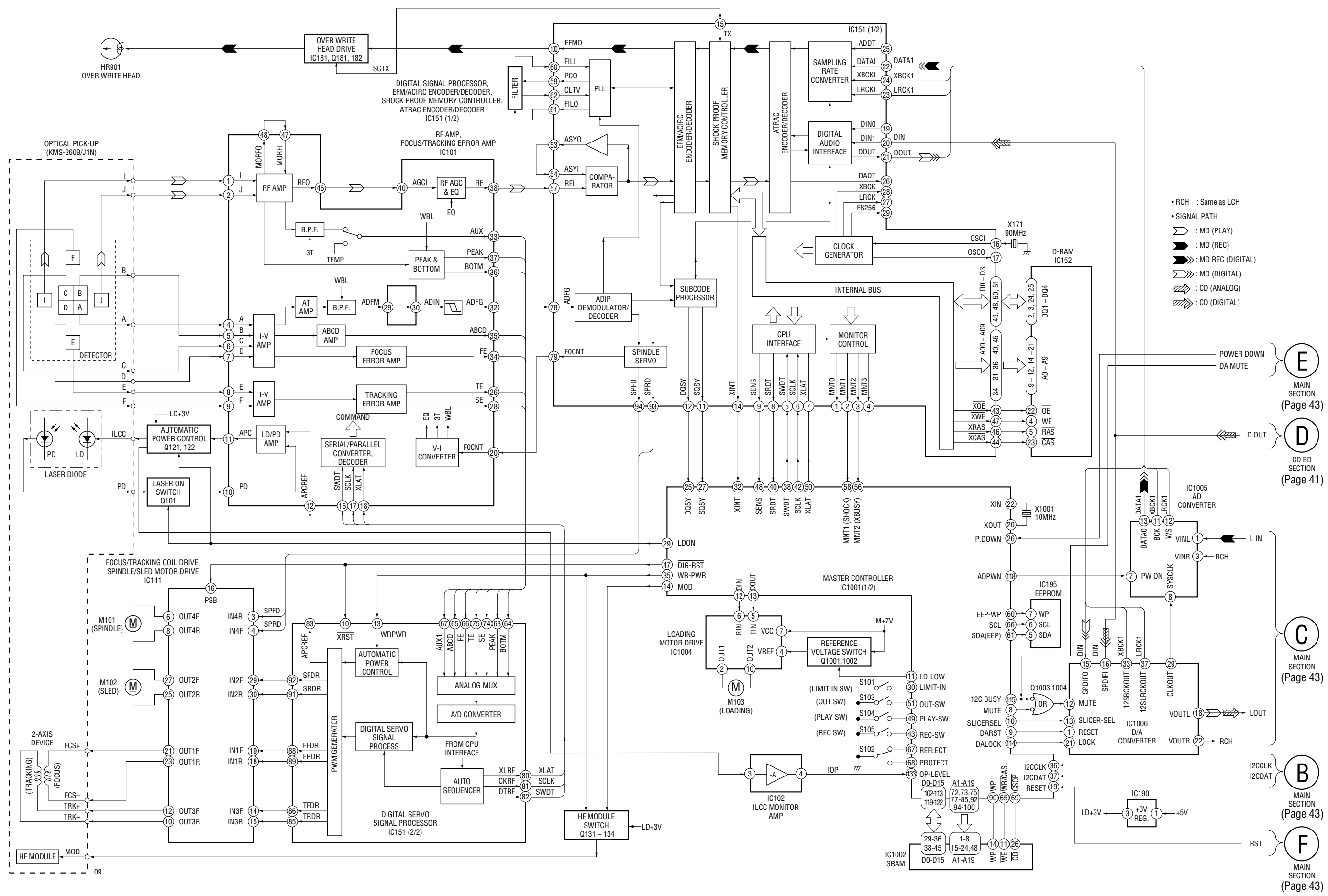

- RCH : Same as LCH
- SIGNAL PATH
- ◁ : MD (PLAY)
- ▶ : MD (REC)
- ◁▶ : MD REC (DIGITAL)
- ◁▶ : MD (DIGITAL)
- ◁▶ : CD (ANALOG)
- ◁▶ : CD (DIGITAL)

E
MAIN SECTION
(Page 43)

D
CD BD SECTION
(Page 41)

C
MAIN SECTION
(Page 43)

B
MAIN SECTION
(Page 43)

F
MAIN SECTION
(Page 43)

- MAIN SECTION -

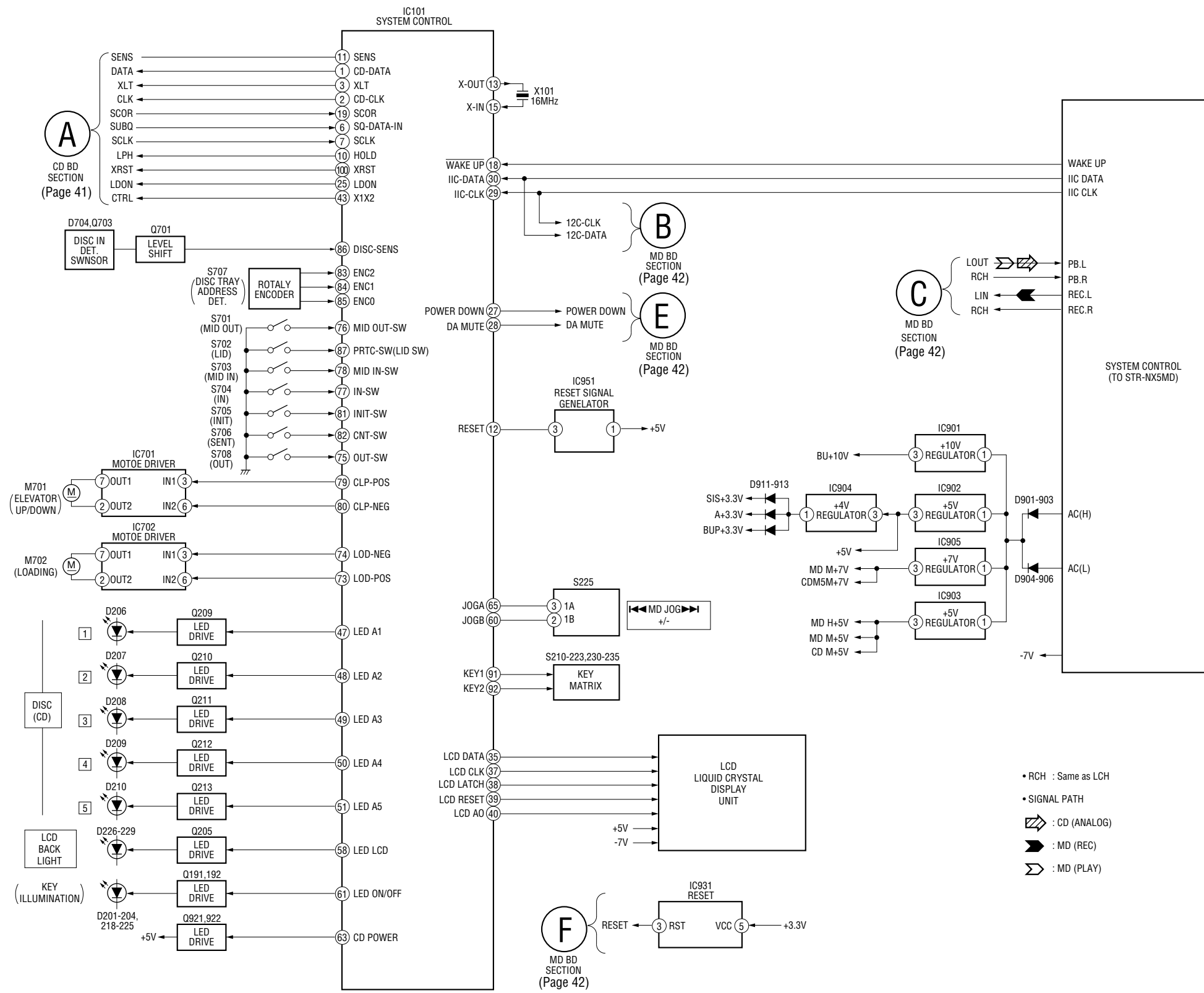

6-3. SCHEMATIC DIAGRAM – CD SECTION –

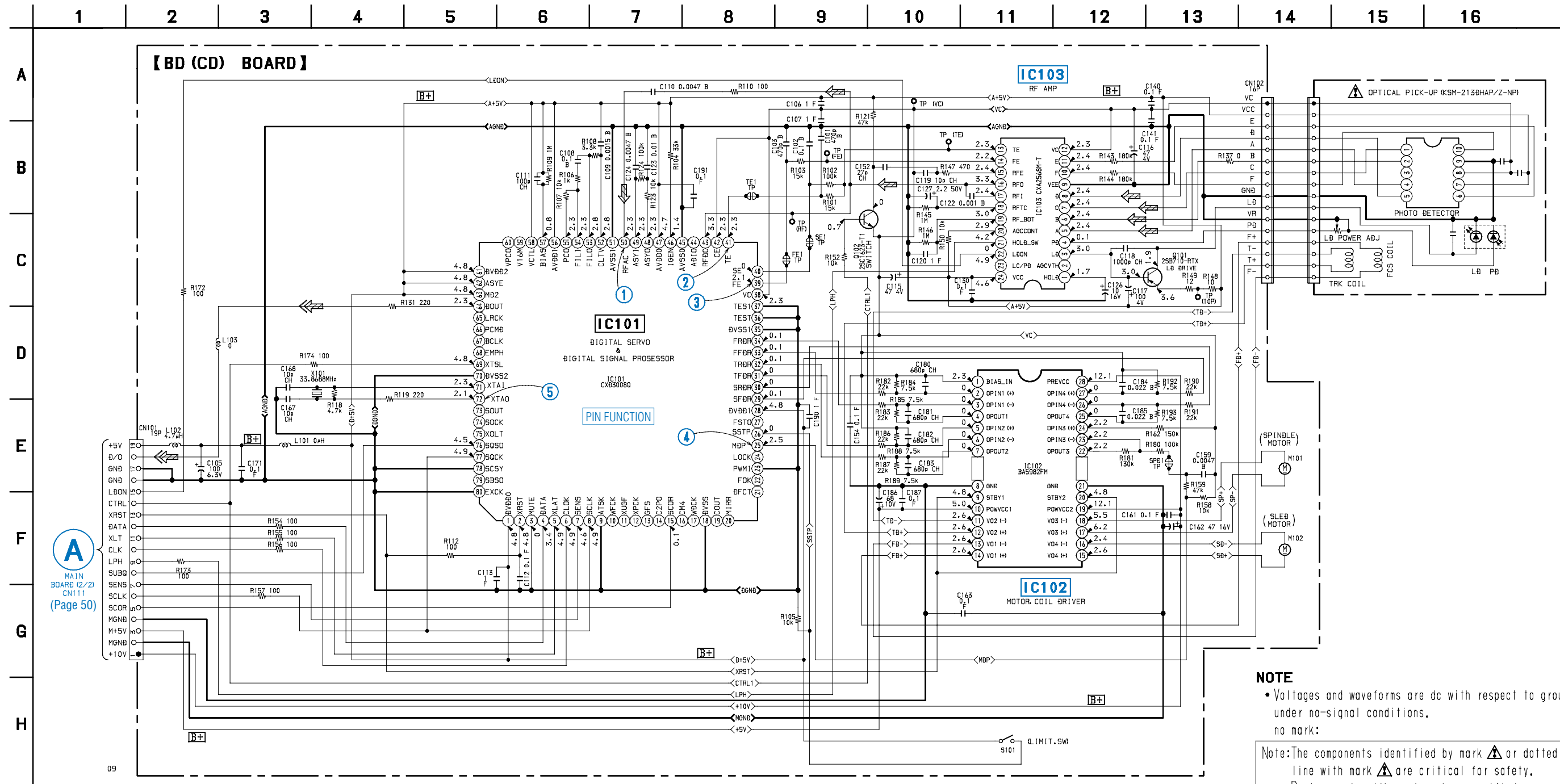

A
MAIN BOARD (2/2)
CN111
(Page 50)

6-4. PRINTED WIRING BOARD – CD SECTION –

【BD (CD) BOARD】(SIDE A)

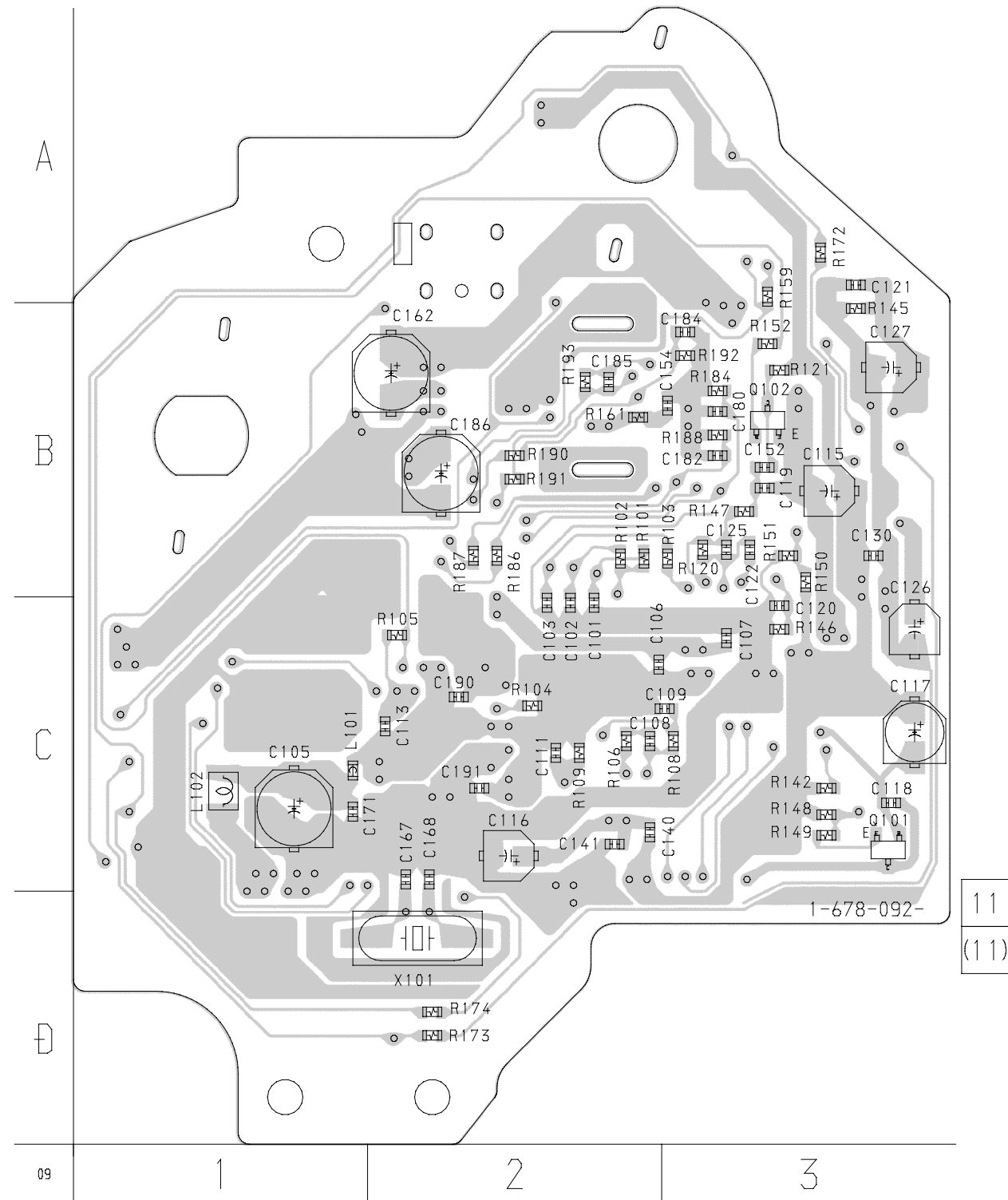

【BD (CD) BOARD】(SIDE B)

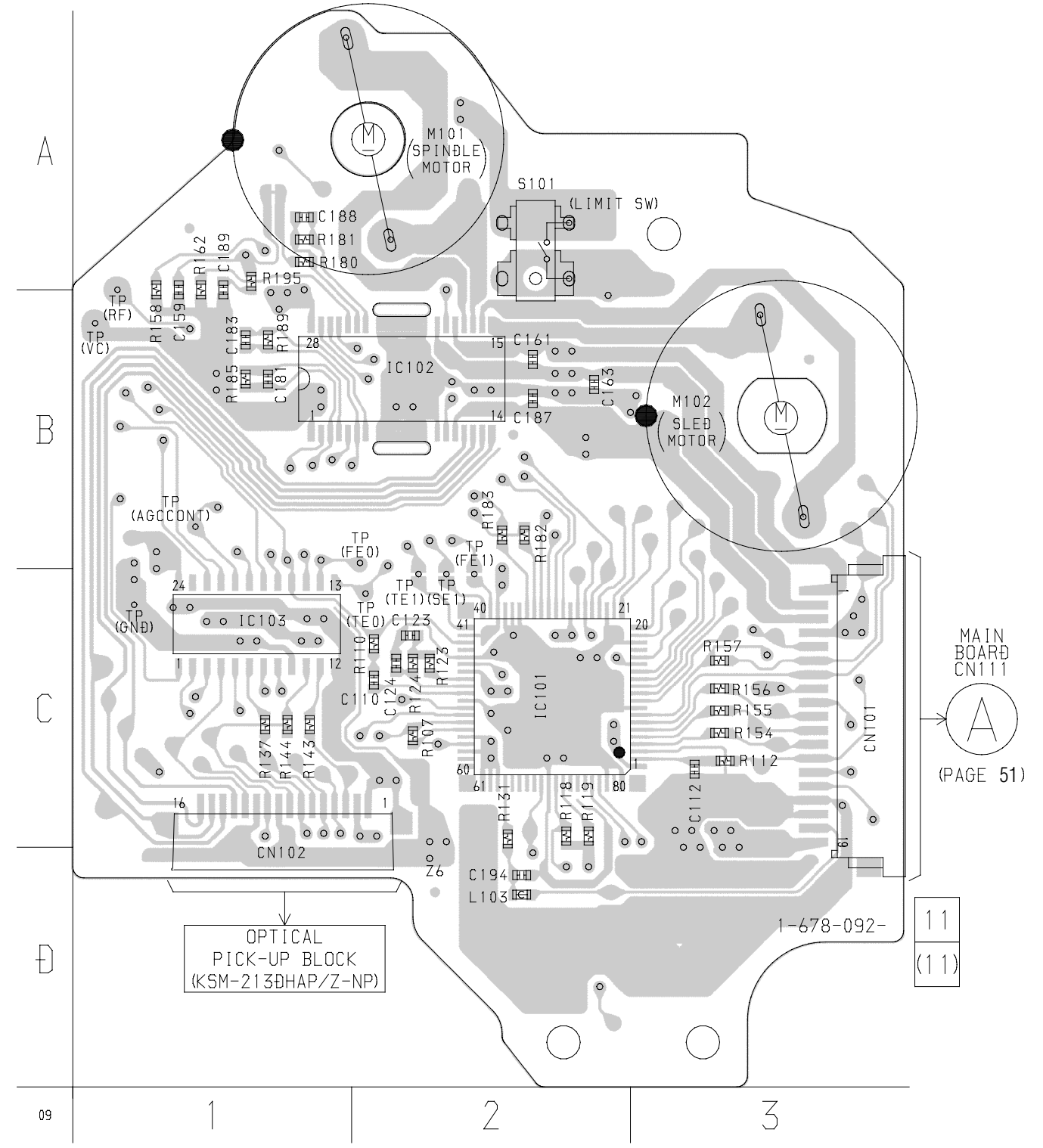

There are a few cases that the part isn't mounted in model is printed on diagram.

6-5. PRINTED WIRING BOARD – MD SECTION –

【BD (MD) BOARD】(SIDE A)

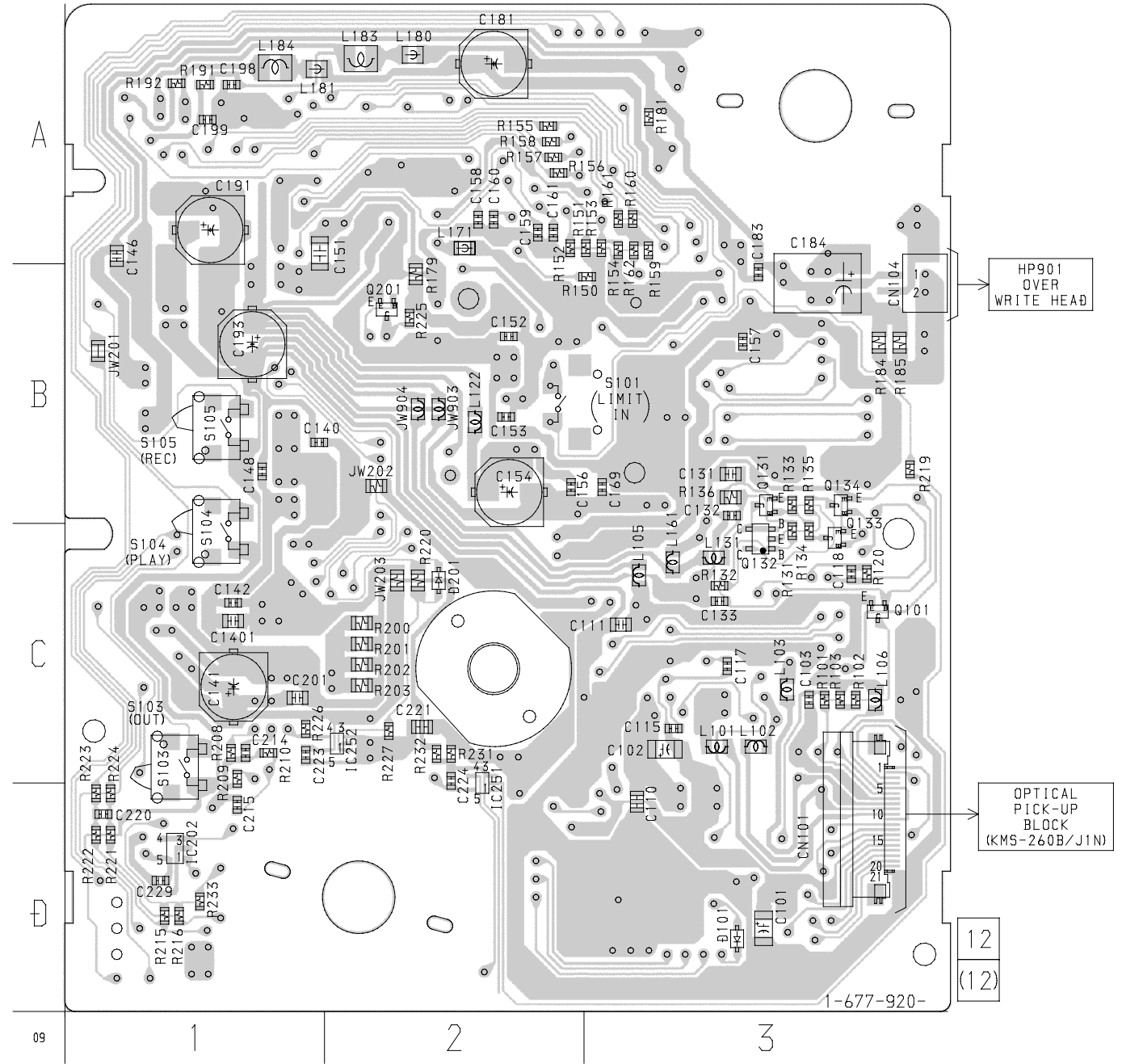

• Semiconductor Location

Ref. No.	Location
D101	D-3
Q101	C-3
Q131	B-3
Q132	C-3
Q133	C-3
Q134	B-3

【BD (MD) BOARD】(SIDE B)

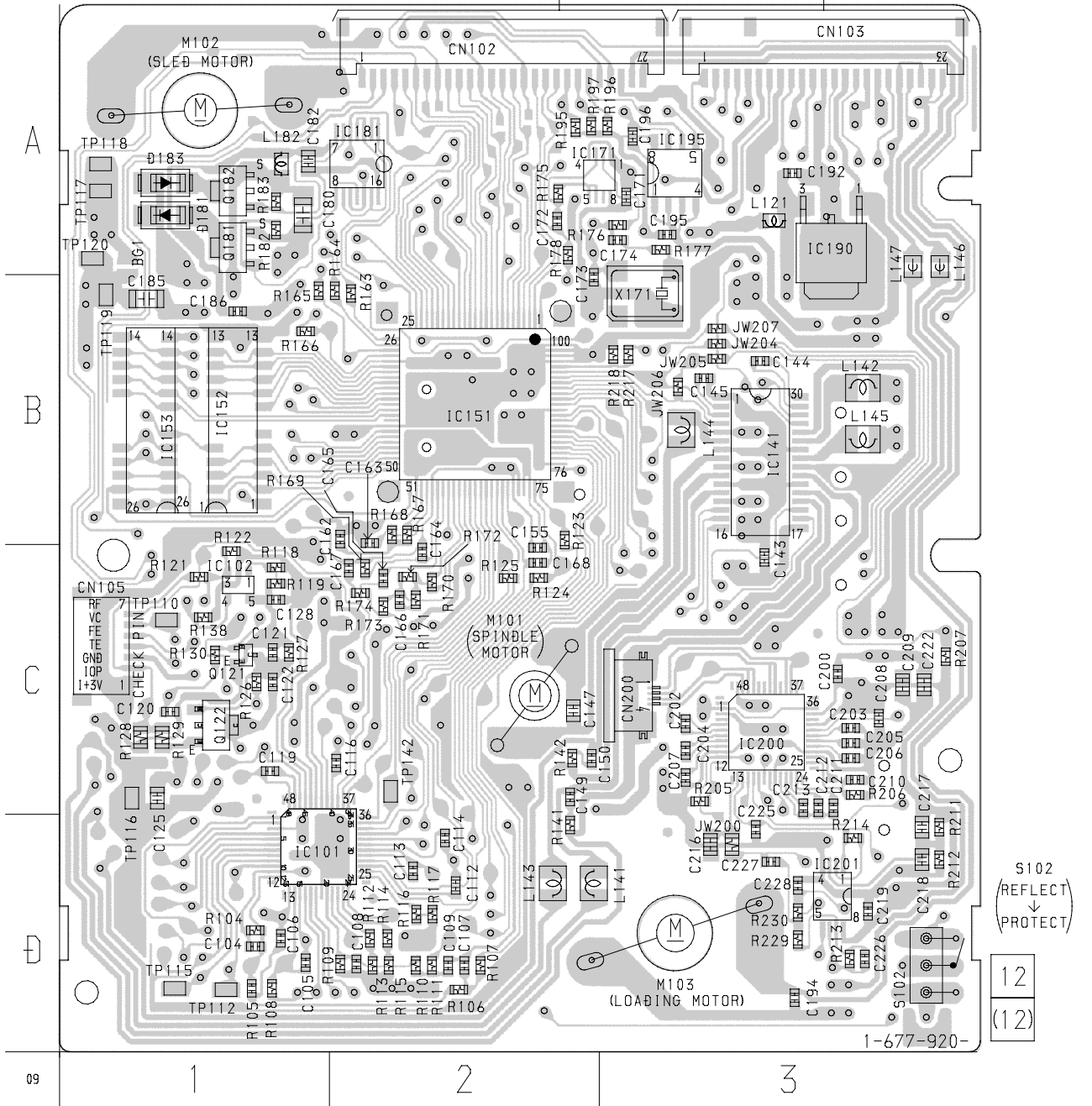

• Semiconductor Location

Ref. No.	Location
D181	A-1
D183	A-1
IC101	D-1
IC102	C-1
IC141	B-3
IC151	B-2
IC181	A-2
IC190	A-3
IC195	A-3
Q121	C-1
Q122	C-1
Q181	A-1
Q182	A-1

There are a few cases that the part isn't mounted in model is printed on diagram.

6-6. SCHEMATIC DIAGRAM – MD SECTION (1/2) –

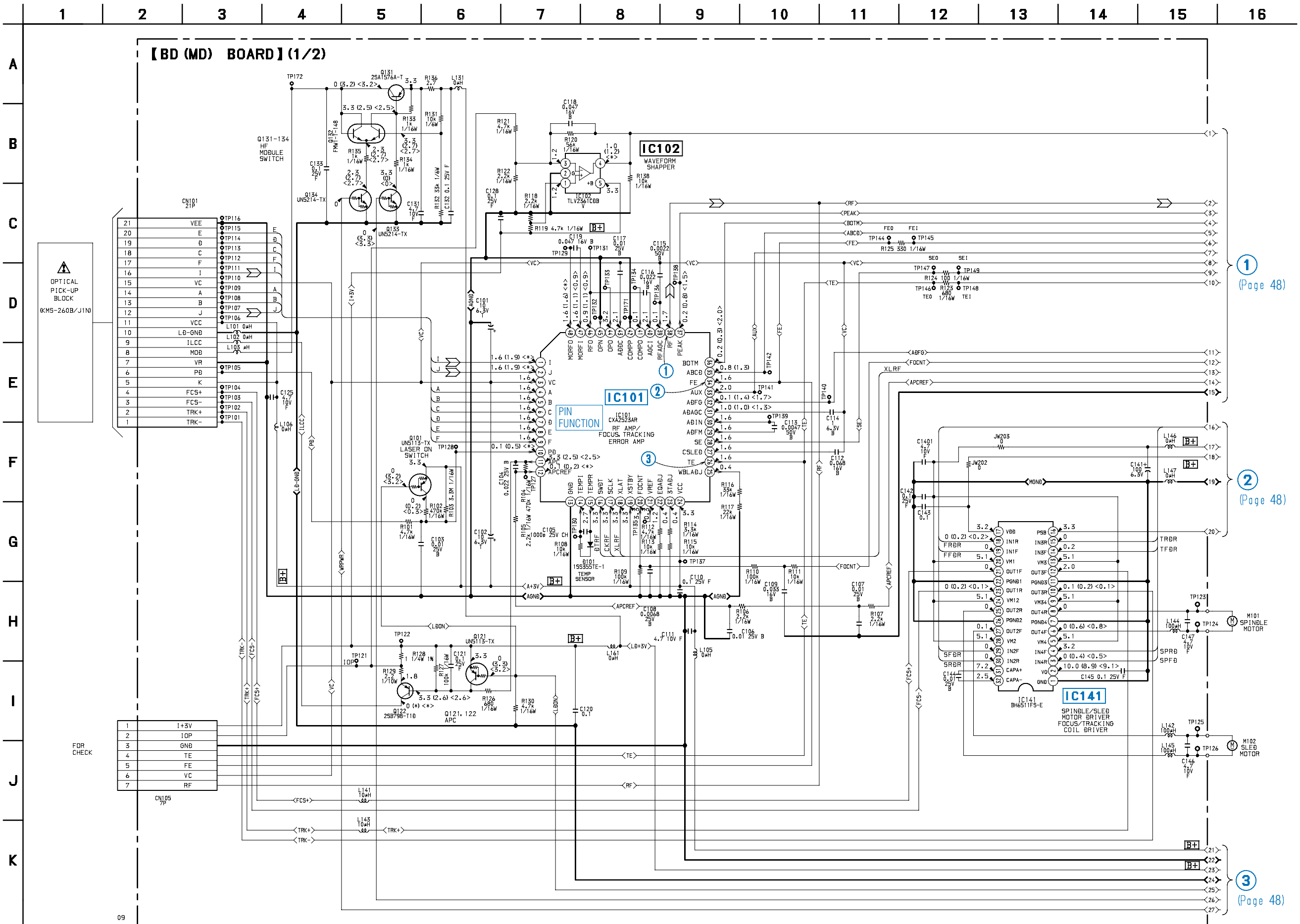

1 (Page 48)

2 (Page 48)

3 (Page 48)

Note: The components identified by mark or dotted line with mark are critical for safety. Replace only with part number specified.

NOTE
• Voltages and waveforms are dc with respect to ground under no-signal conditions.

no mark: STOP
(): PLAY
< >: REC
* : can not be measured.

6-7. SCHEMATIC DIAGRAM – MD SECTION (2/2) –

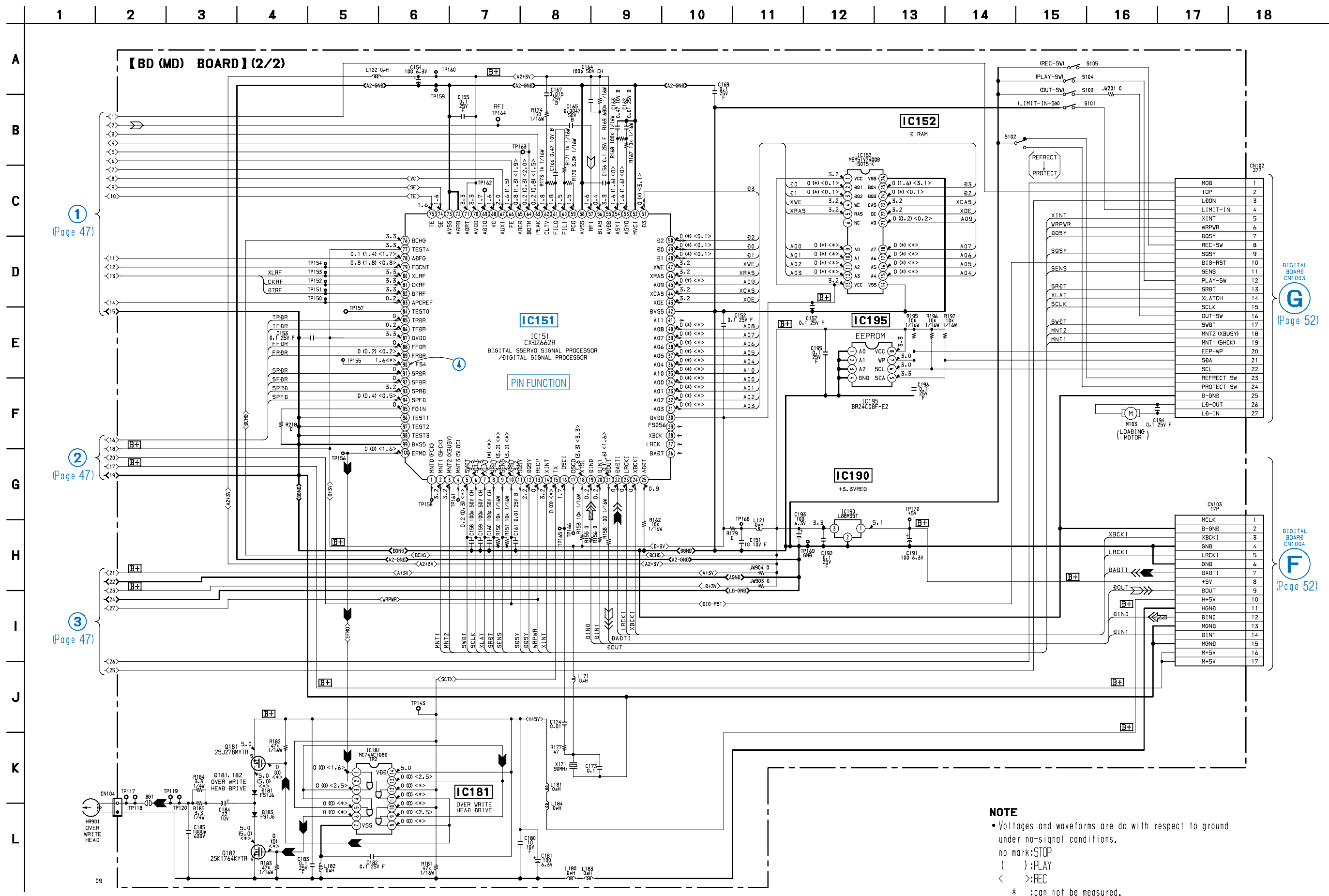

1 (Page 47)

2 (Page 47)

3 (Page 47)

DIGITAL BOARD CN1005 (Page 52)

DIGITAL BOARD CN1004 (Page 52)

NOTE

- Voltages and waveforms are dc with respect to ground under no-signal conditions.
- no mark: STOP
- (): PLAY
- < >: REC
- * : can not be measured.

6-8. SCHEMATIC DIAGRAM – MAIN SECTION (1/2) –

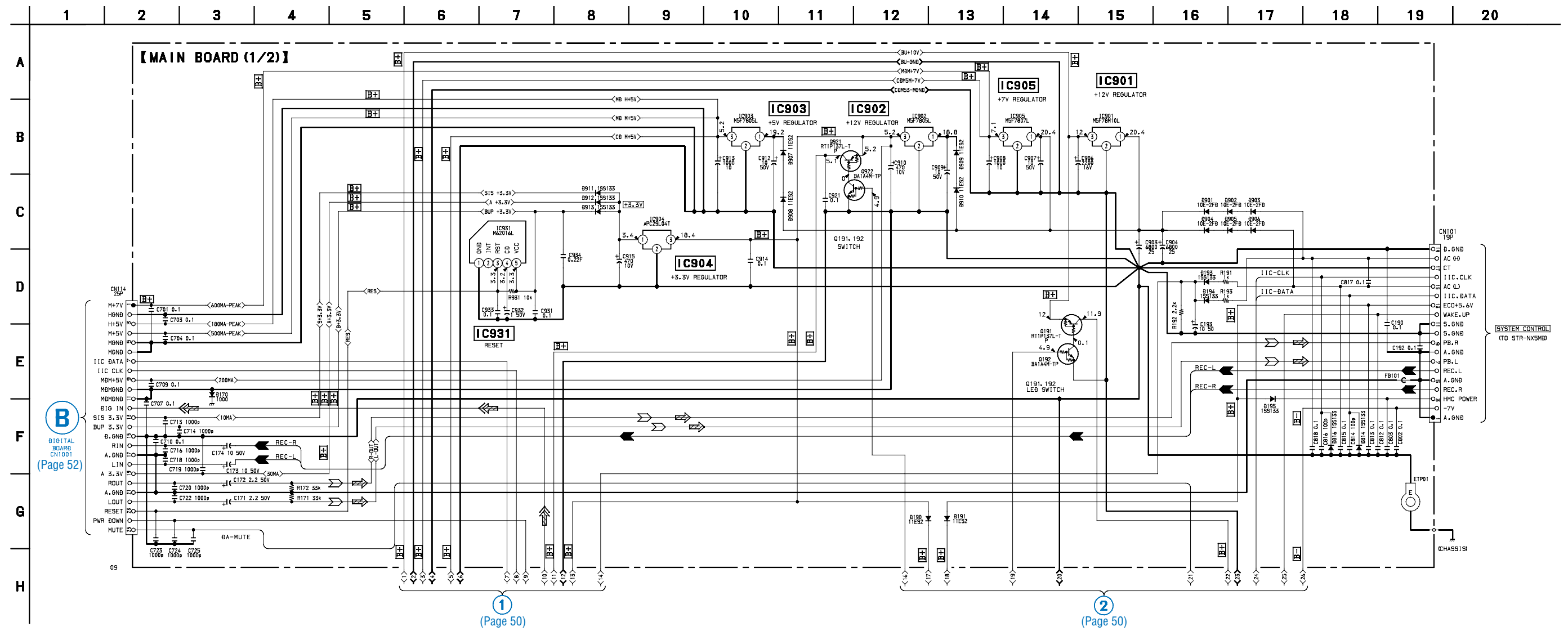

6-9. SCHEMATIC DIAGRAM – MAIN SECTION (2/2) –

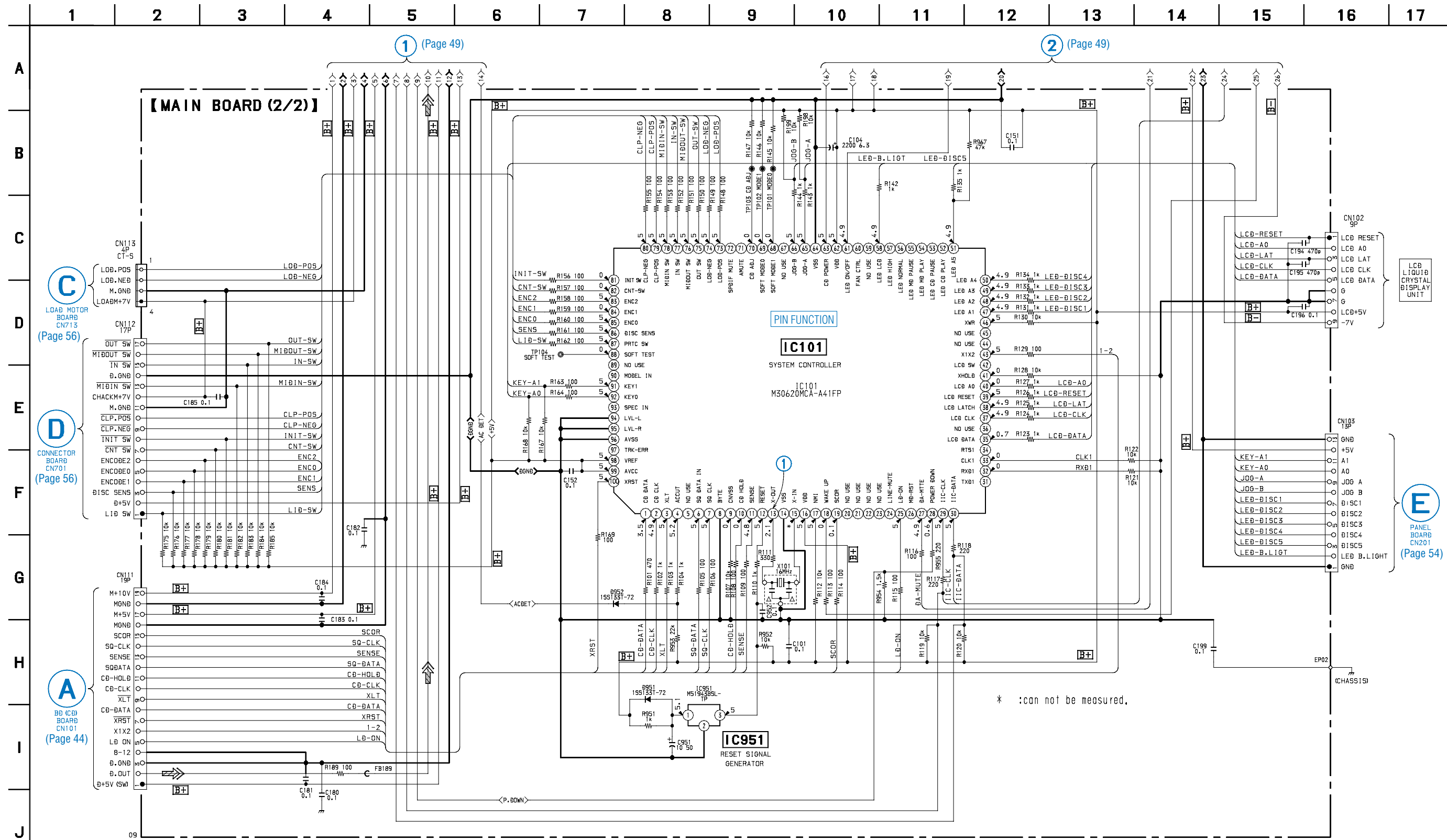

6-10. PRINTED WIRING BOARD – MAIN SECTION –

【MAIN BOARD】

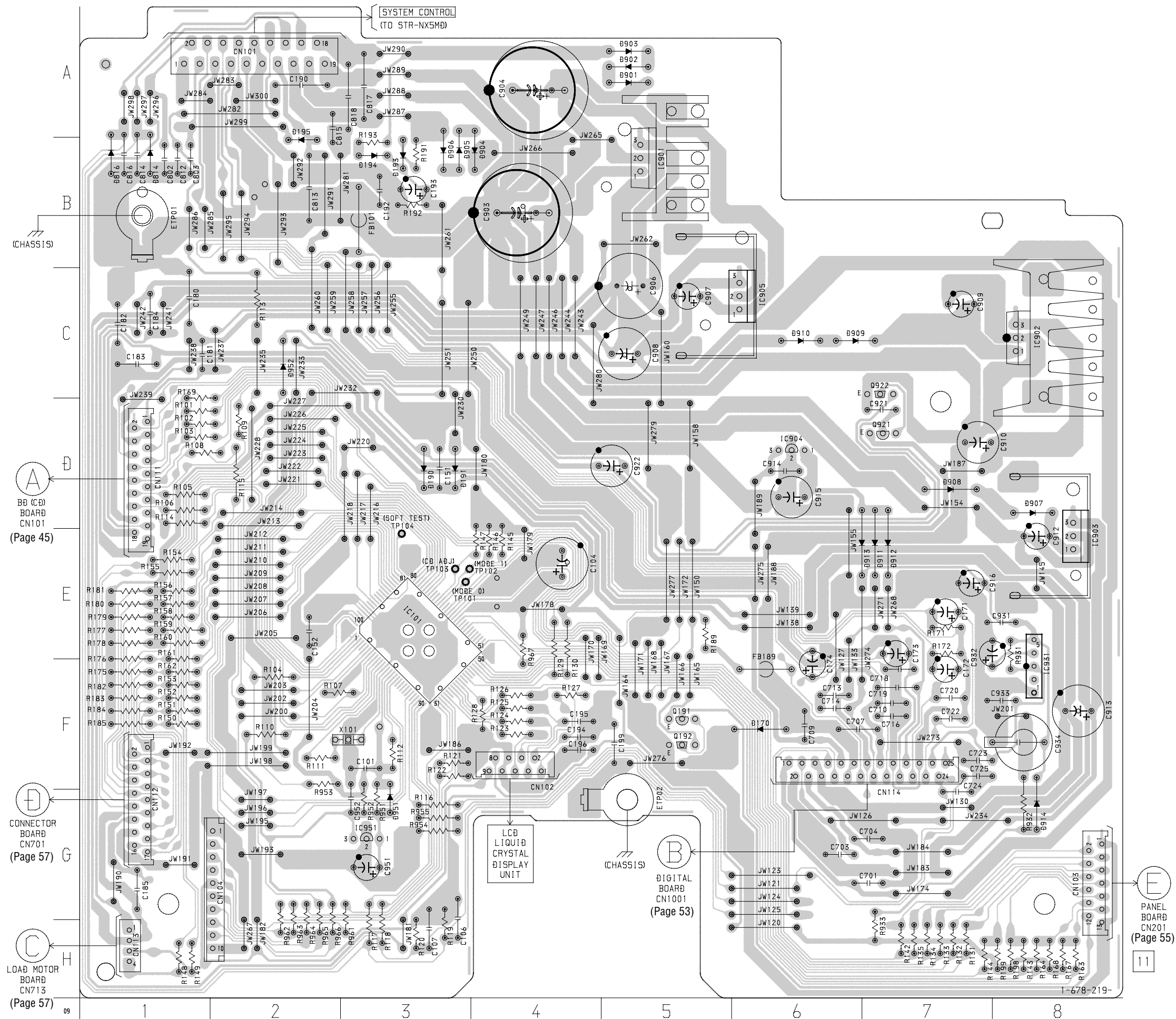

• Semiconductor Location

Ref. No.	Location
D171	
D190	D-3
D191	D-3
D193	B-3
D194	B-3
D195	A-2
D814	B-1
D816	B-1
D901	A-5
D902	A-5
D903	A-5
D904	B-4
D905	B-3
D906	B-3
D907	D-8
D908	D-7
D909	C-6
D910	C-6
D911	E-7
D912	E-7
D913	E-7
D951	G-3
D952	C-2
IC101	E-3
IC901	B-5
IC902	C-8
IC903	E-8
IC904	D-6
IC905	C-6
IC931	F-8
IC951	G-3
Q191	F-5
Q192	F-5
Q921	C-7
Q922	D-7

There are a few cases that the part isn't mounted in model is printed on diagram.

6-11. SCHEMATIC DIAGRAM – DIGITAL SECTION –

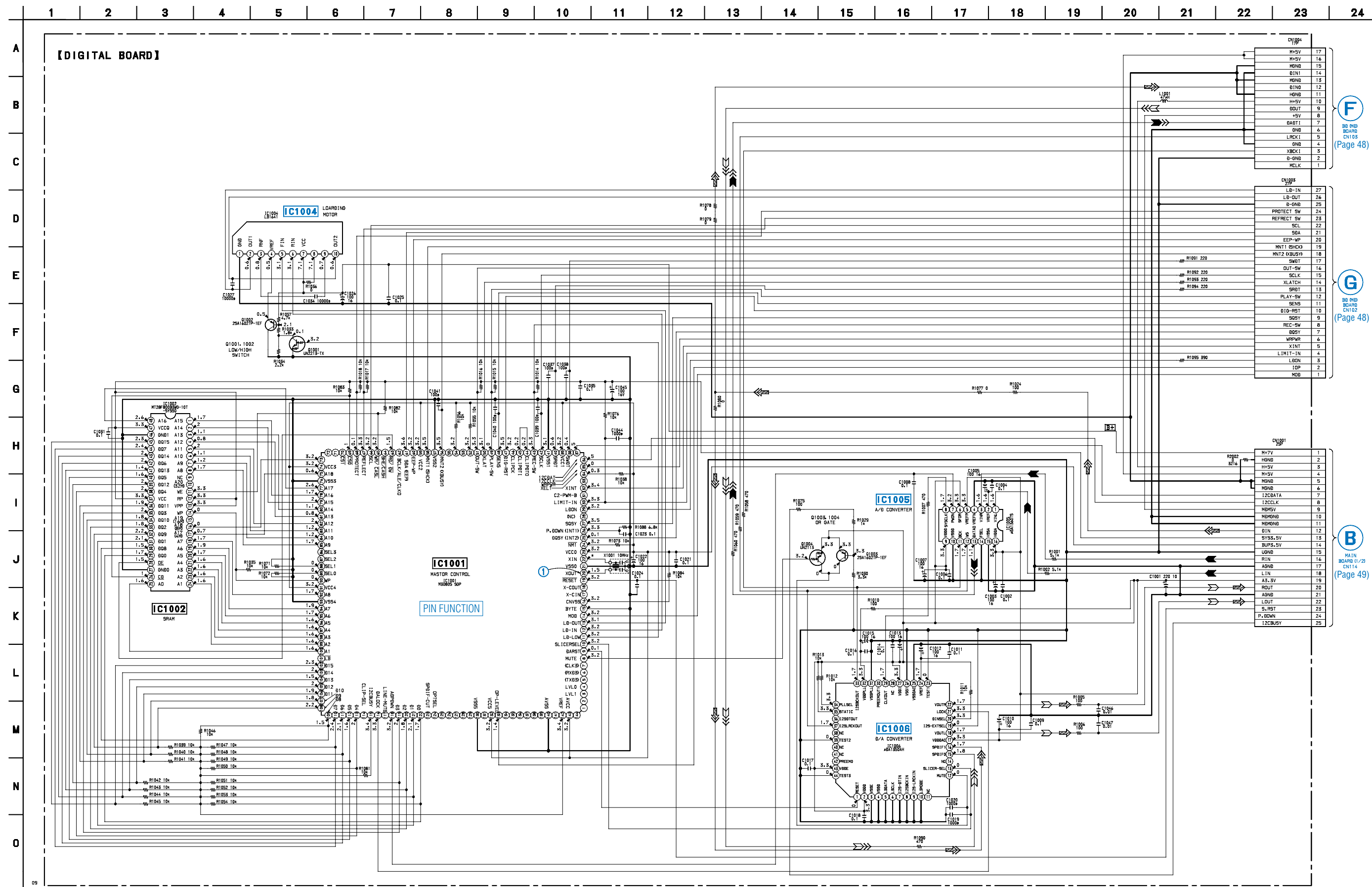

F BB PWB BOARD CN103 (Page 48)

G BB PWB BOARD CN102 (Page 48)

B MAIN BOARD U/23 CN114 (Page 49)

6-12. PRINTED WIRING BOARD – DIGITAL SECTION –

【DIGITAL BOARD】(SIDE A)

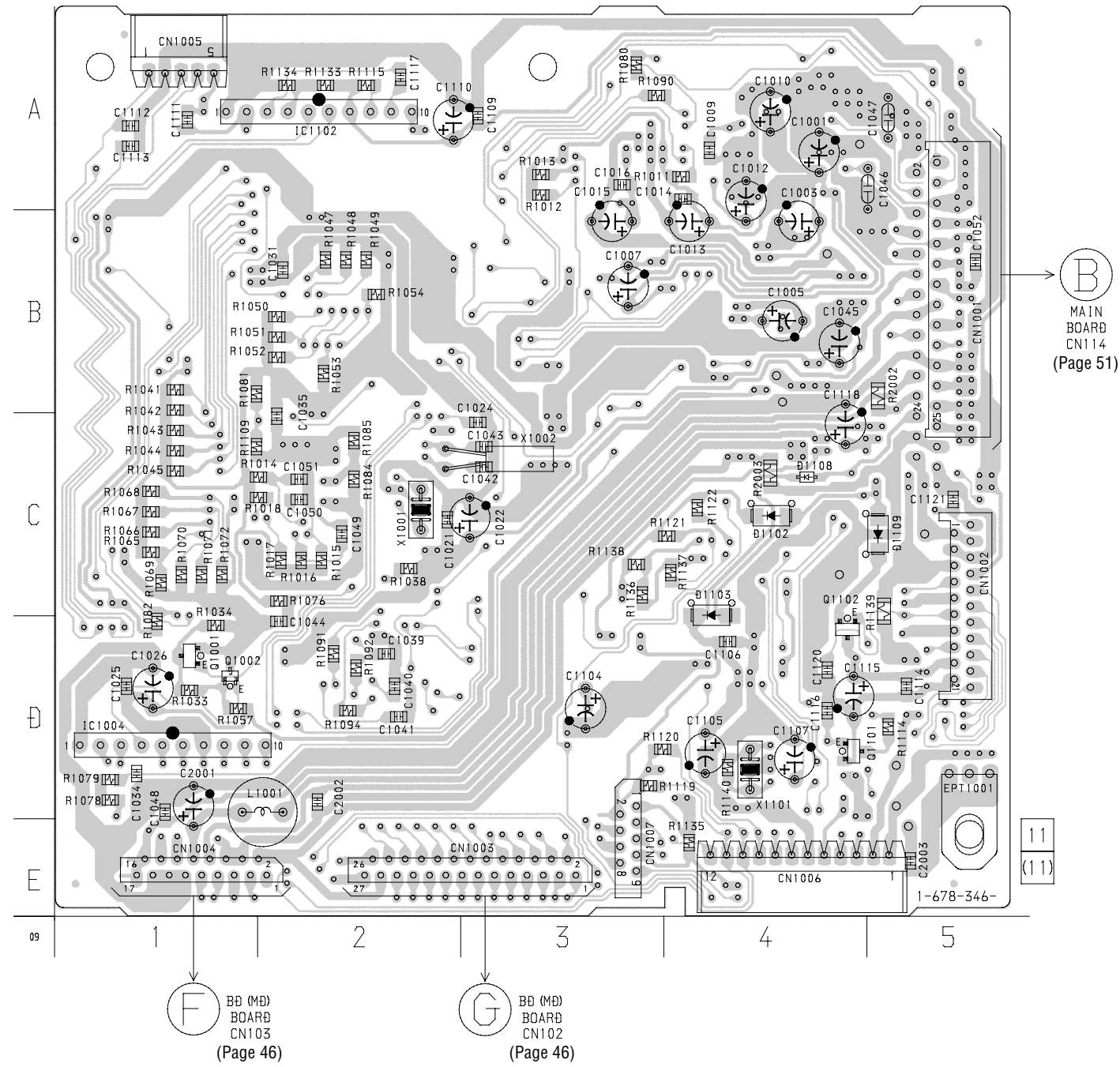

• Semiconductor Location

Ref. No.	Location
IC1004	D-1
Q1001	D-1
Q1002	D-1

【DIGITAL BOARD】(SIDE B)

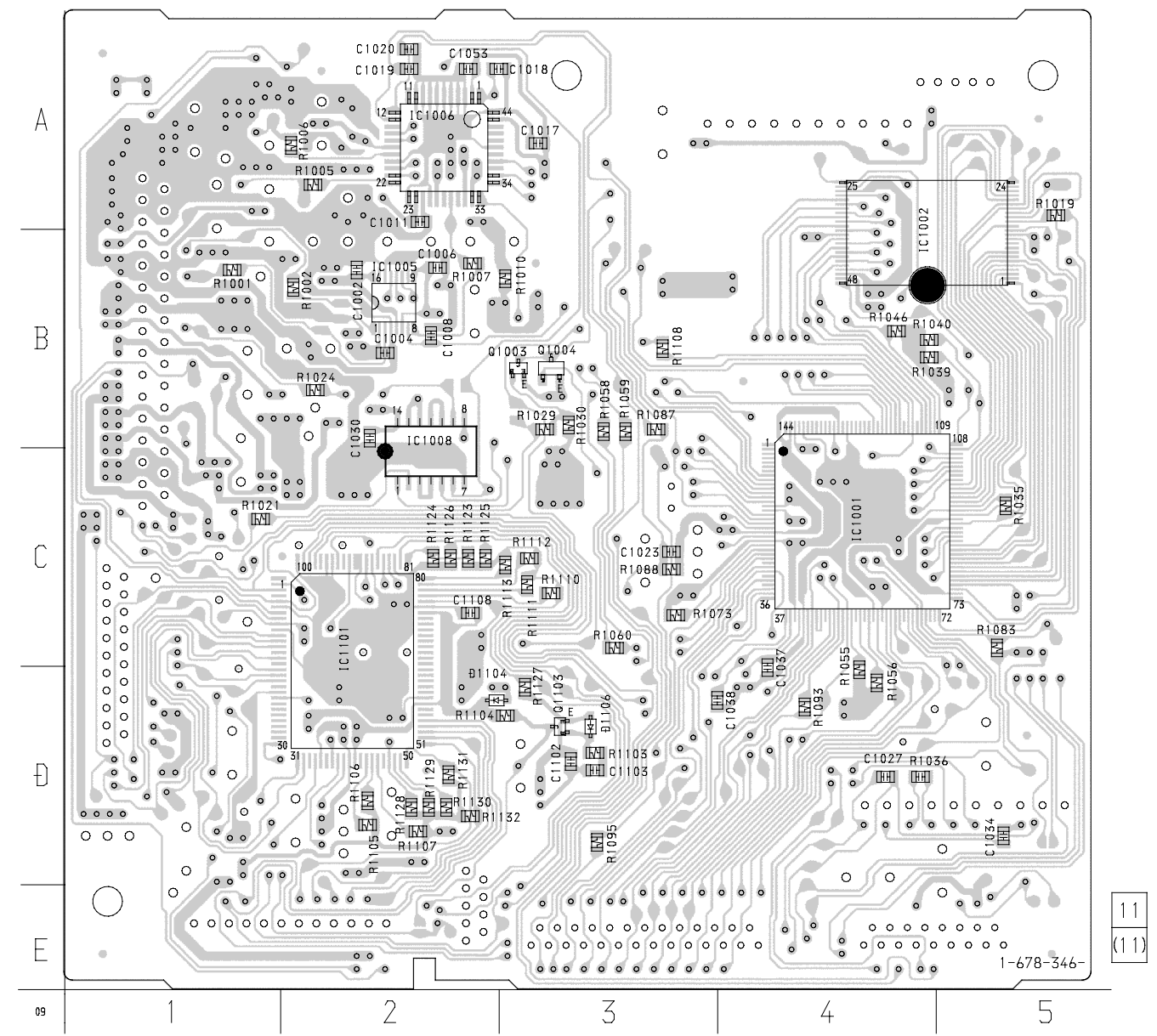

• Semiconductor Location

Ref. No.	Location
IC1001	C-4
IC1002	B-4
IC1005	B-2
IC1006	A-2
Q1003	B-3
Q1004	B-3

There are a few cases that the part isn't mounted in model is printed on diagram.

6-13. SCHEMATIC DIAGRAM – PANEL SECTION –

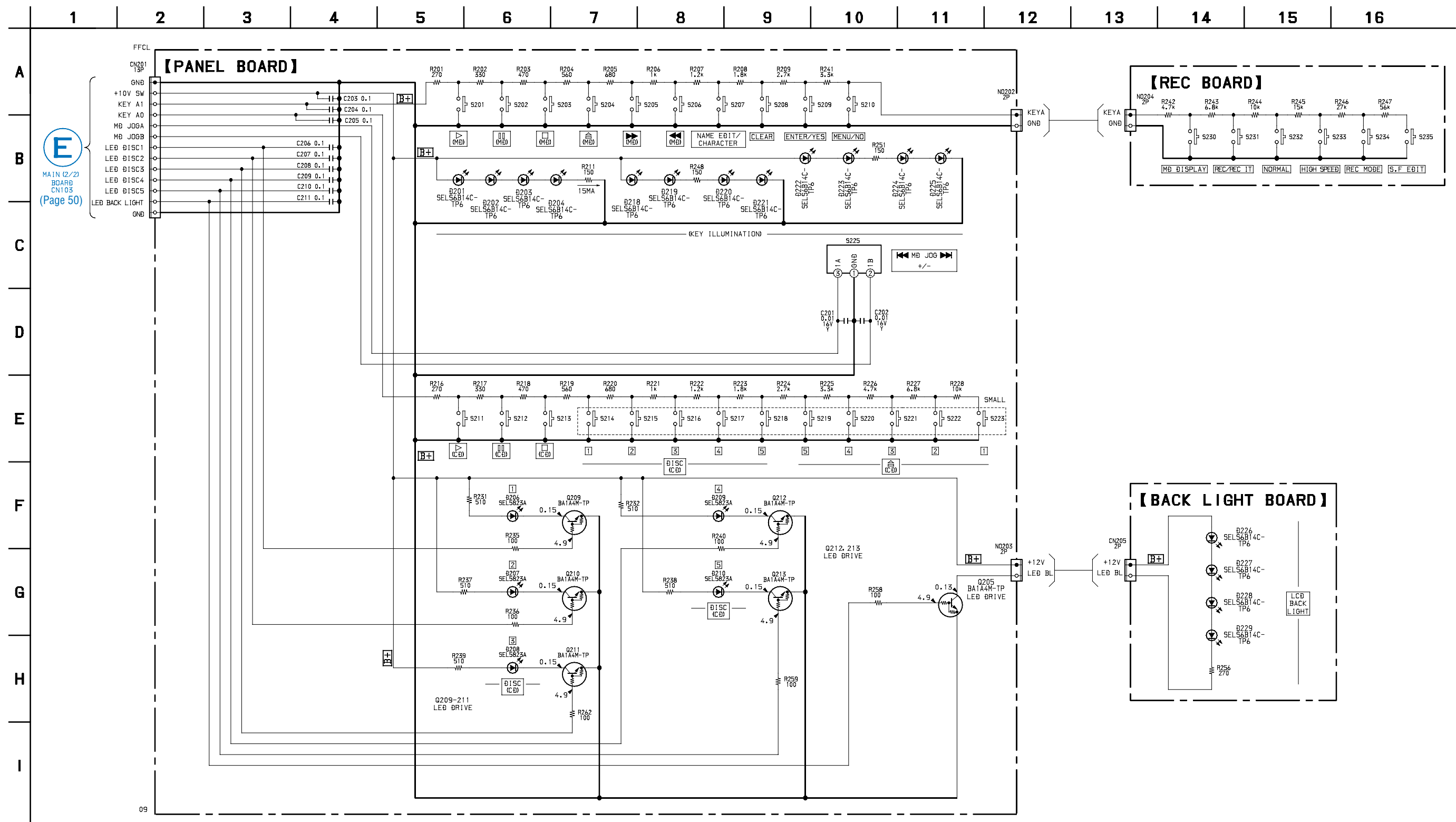

E
MAIN (2/2)
BOARD
CN103
(Page 50)

6-14. PRINTED WIRING BOARD – PANEL SECTION –

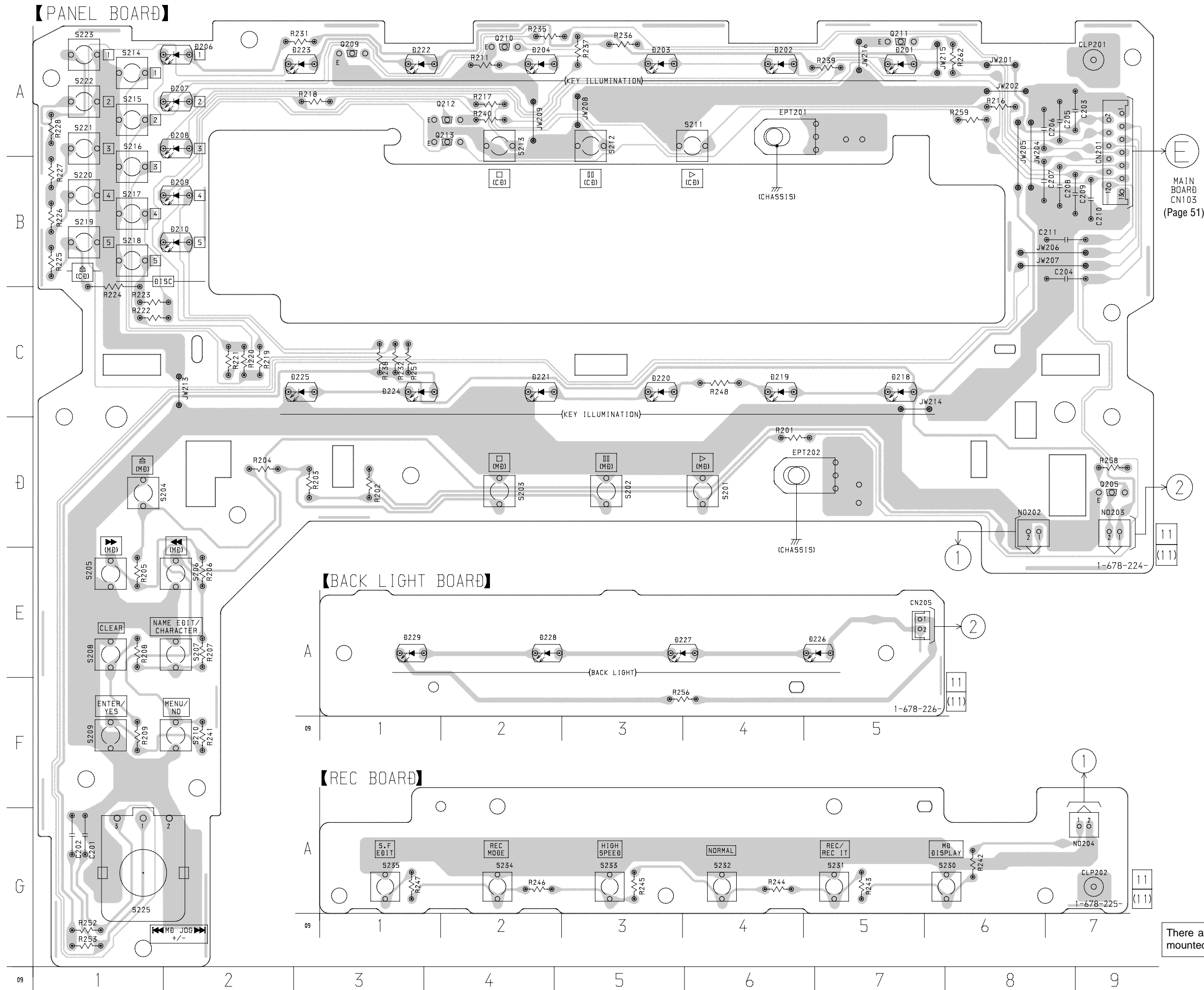

• Semiconductor Location

Ref. No.	Location
D201	A-7
D202	A-6
D203	A-5
D204	A-4
D206	A-2
D207	A-2
D208	A-2
D209	B-2
D210	B-2
D218	C-7
D219	C-6
D220	C-5
D221	C-4
D222	A-4
D223	A-3
D224	C-3
D225	C-3
Q205	D-9
Q209	A-3
Q210	A-4
Q211	A-7
Q212	A-4
Q213	A-4

There are a few cases that the part isn't mounted in model is printed on diagram.

6-15. SCHEMATIC DIAGRAM – CD MECHANISM SECTION –

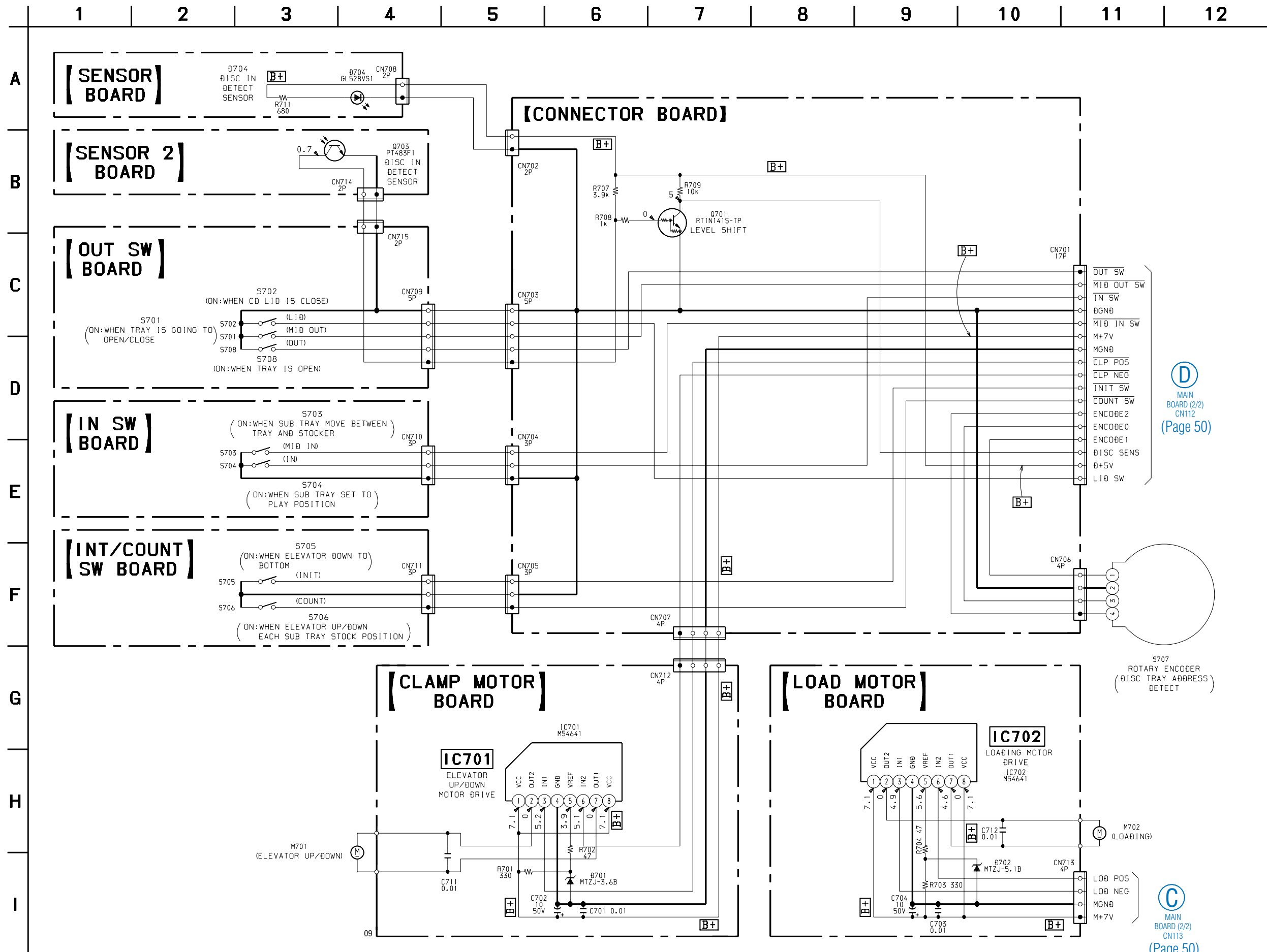

D
MAIN BOARD (2/2)
CN112
(Page 50)

C
MAIN BOARD (2/2)
CN113
(Page 50)

6-16. PRINTED WIRING BOARD – CD MECHANISM SECTION – • See page 39 for Circuit Boards Location.

【SENSOR BOARD】

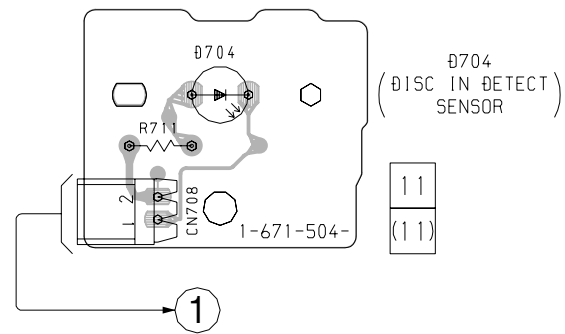

【SENSOR 2 BOARD】

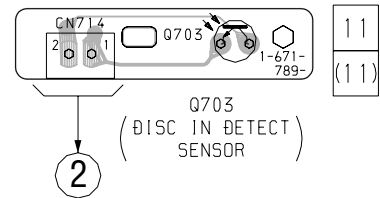

【OUT SW BOARD】

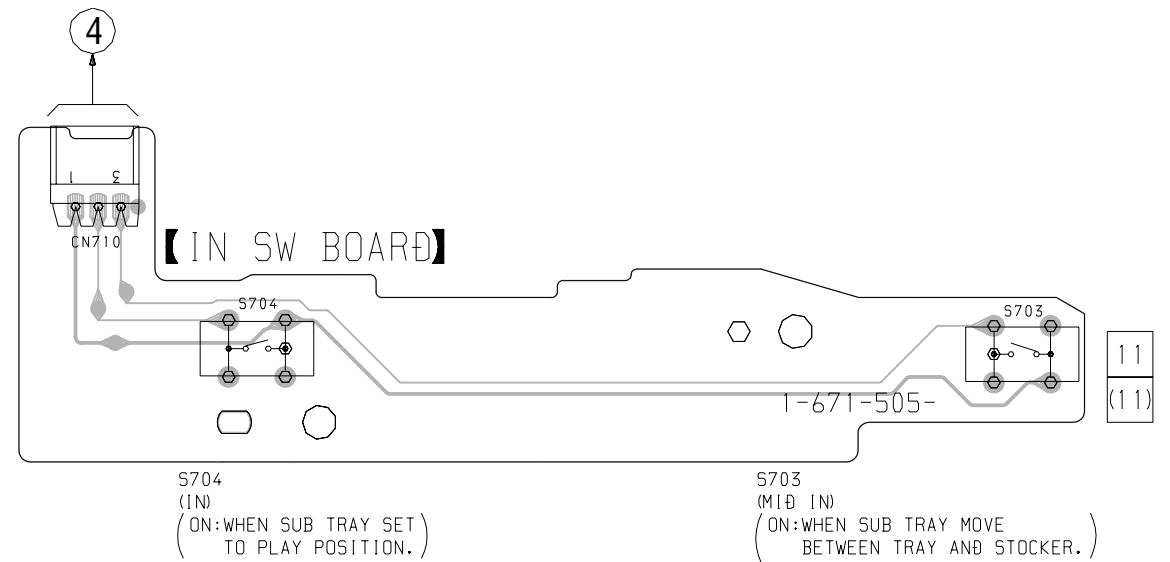
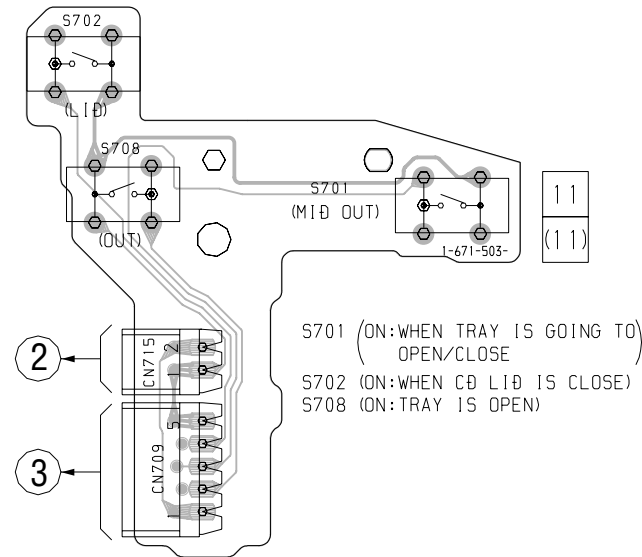

【CLAMP MOTOR BOARD】

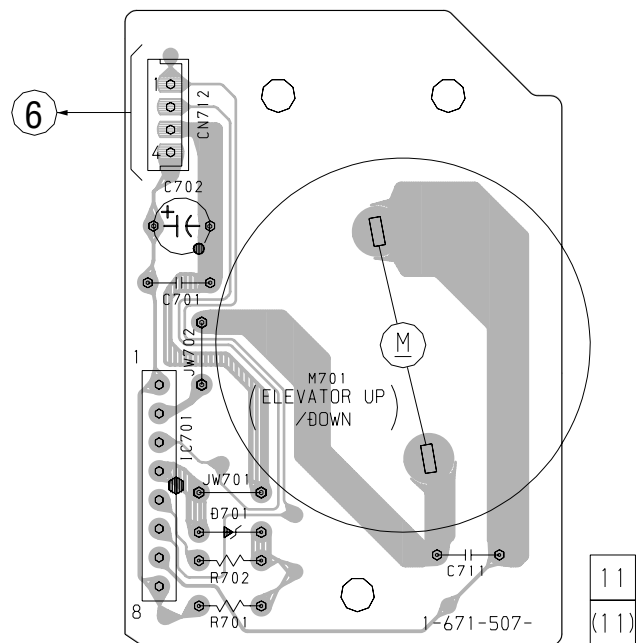

【LOAD MOTOR BOARD】

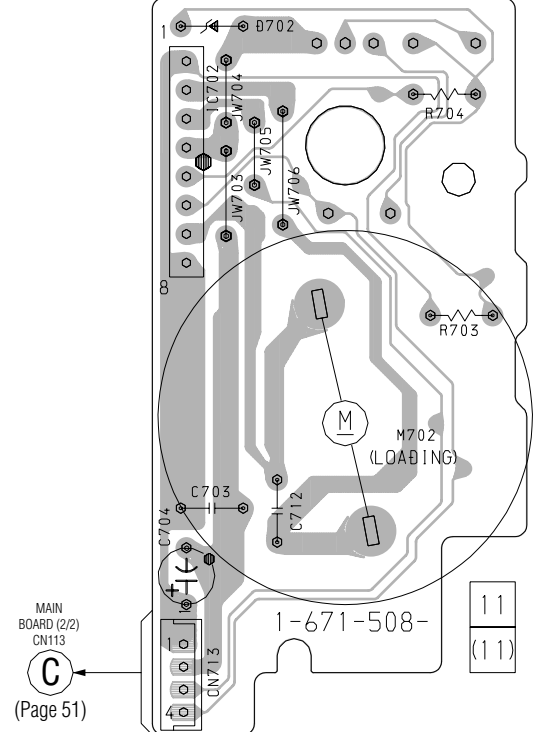

【CONNECTOR BOARD】

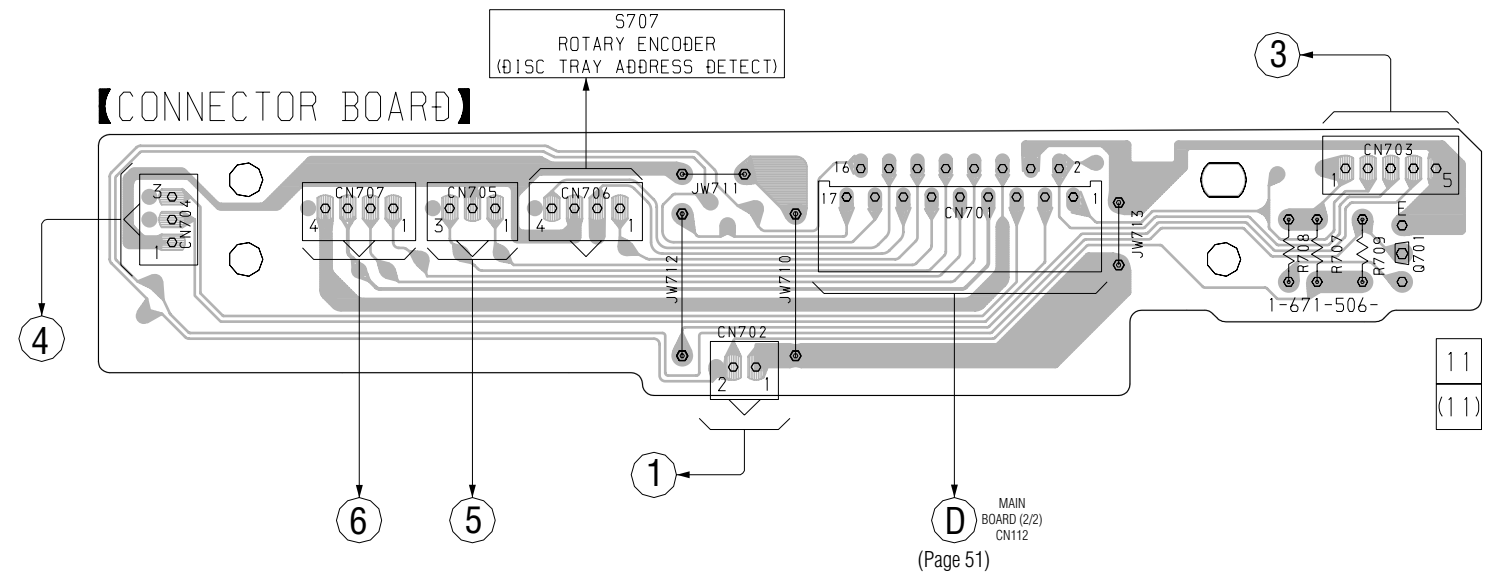

【INT/COUNT SW BOARD】

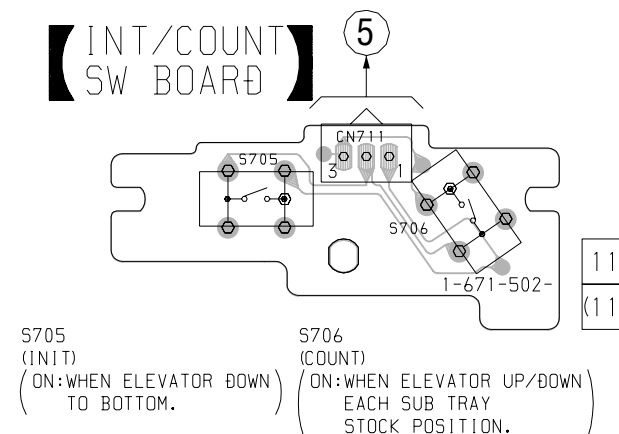

There are a few cases that the part isn't mounted in model is printed on diagram.

• WAVEFORMS

– BD (MD) SECTION –

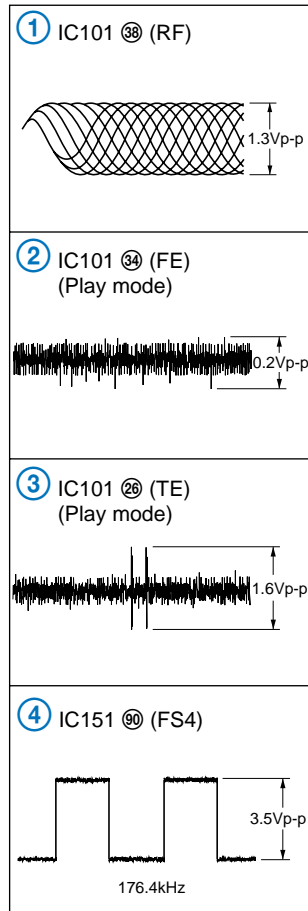

– BD (CD) SECTION –

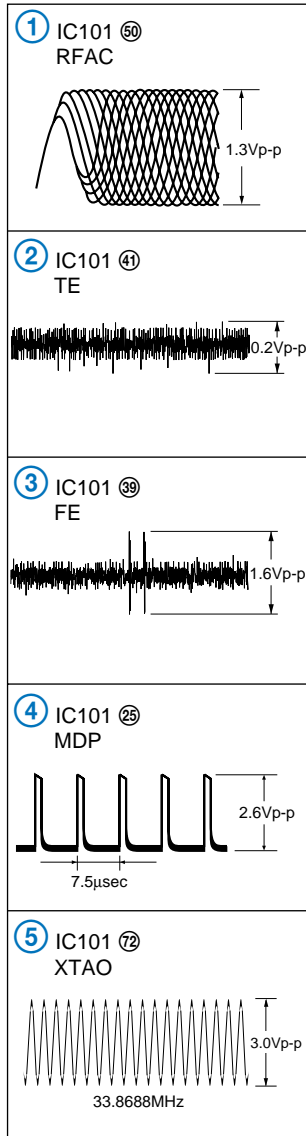

– MAIN SECTION –

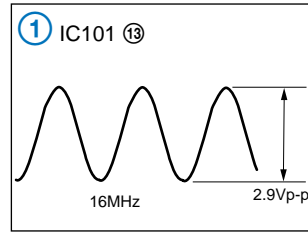

– MD DIGITAL SECTION –

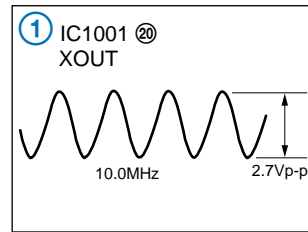

6-17. IC BLOCK DIAGRAMS

IC101 CXA2523AR (BD (MD) BOARD)

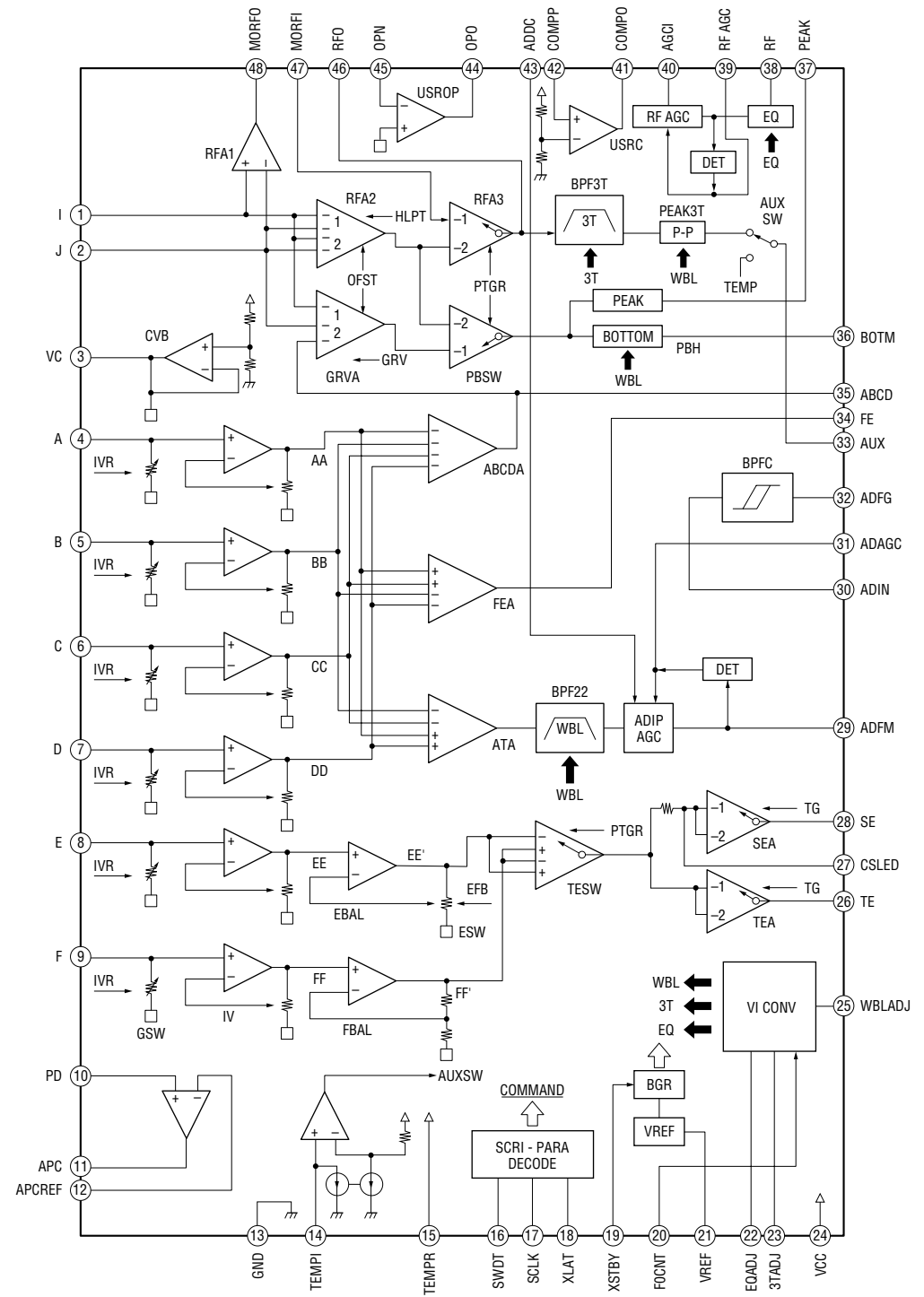

IC151 CXD2662R (BD (MD) BOARD)

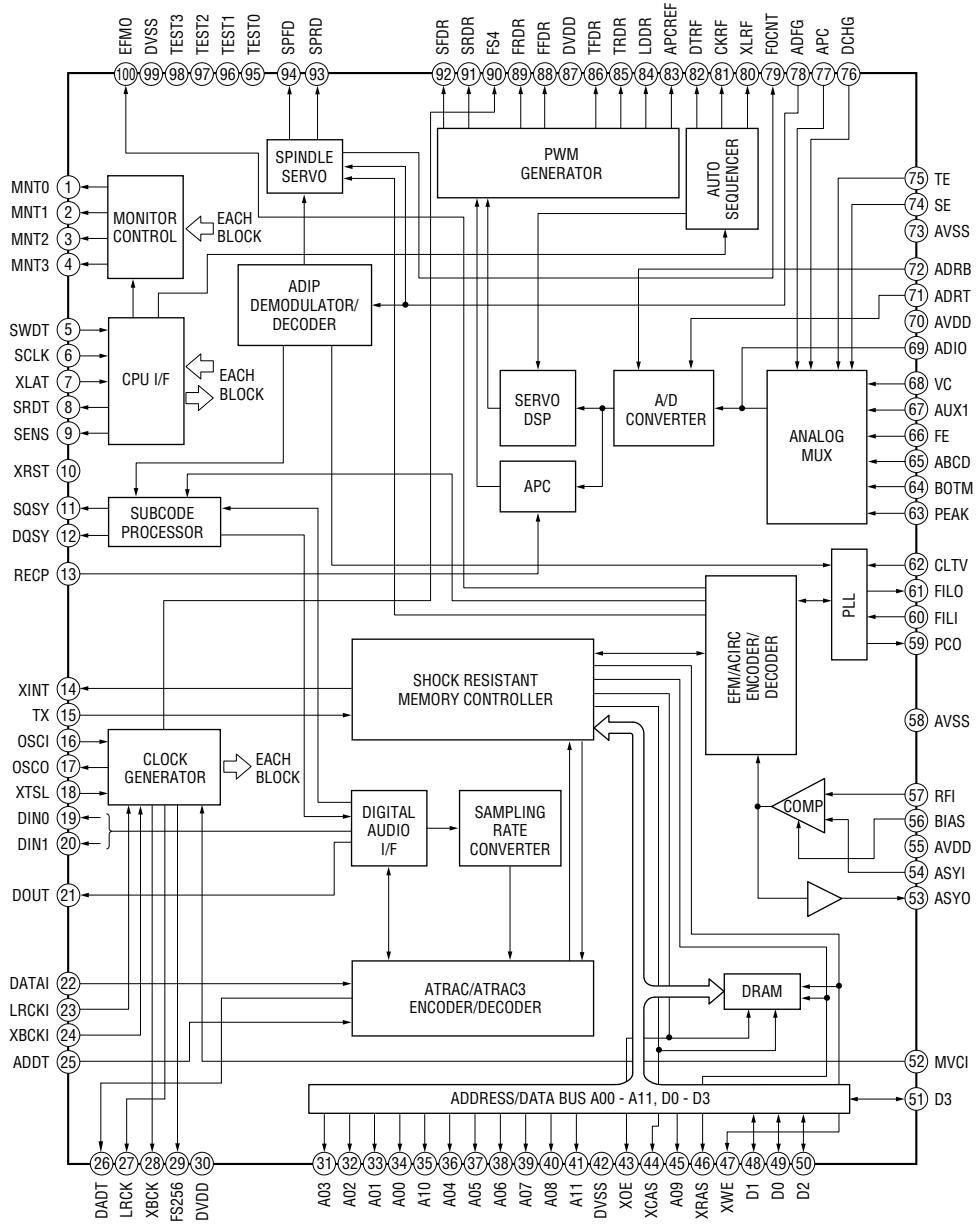

IC141 BH6511FS-E2 (BD (MD) BOARD)

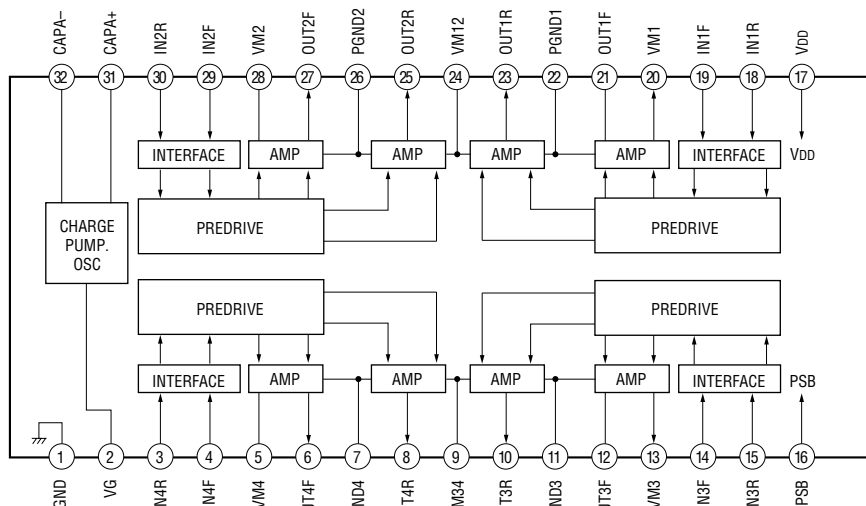

IC102 BA5982FM (BD (CD) BOARD)

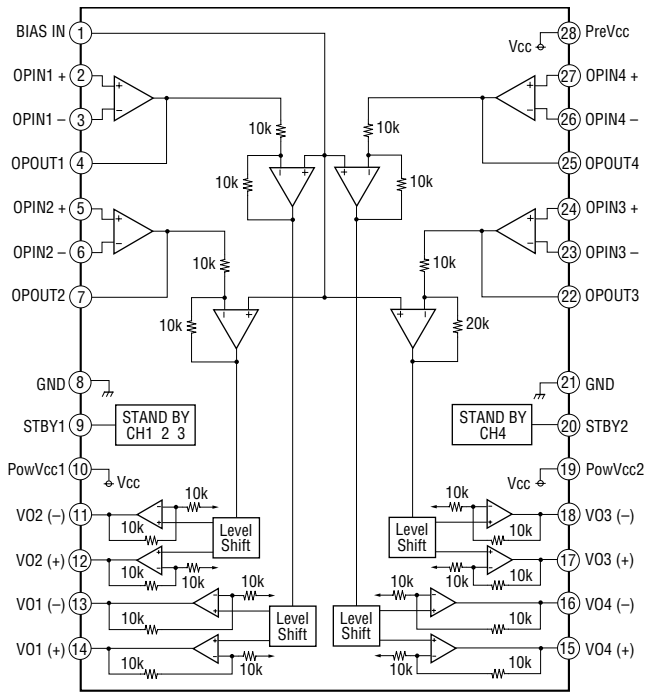

IC103 CXA2568M-T6 (BD (CD) BOARD)

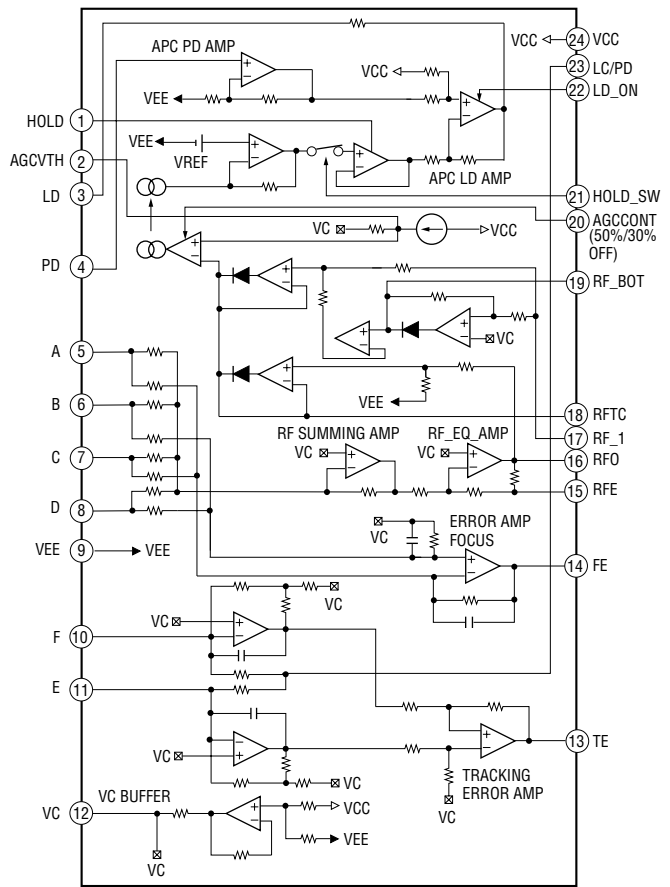

IC1004 LB1641 (DIGITAL BOARD)

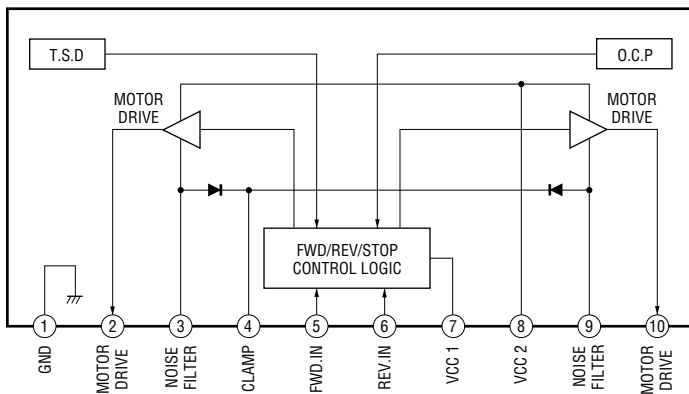

IC1005 μ DA1360TS (DIGITAL BOARD)

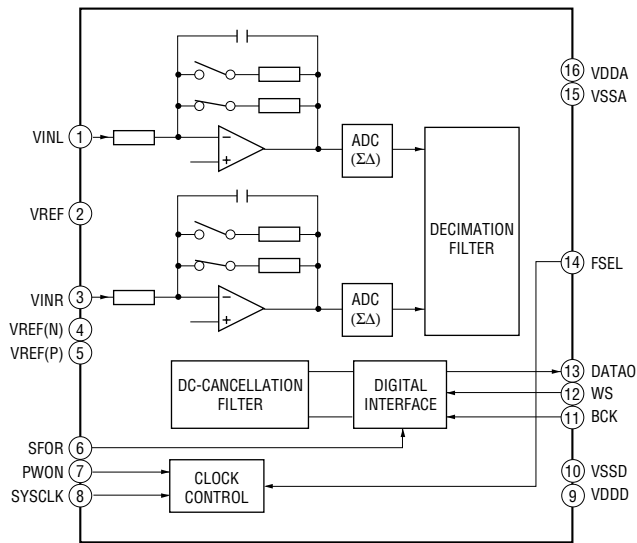

IC1006 μ DA1350AH (DIGITAL BOARD)

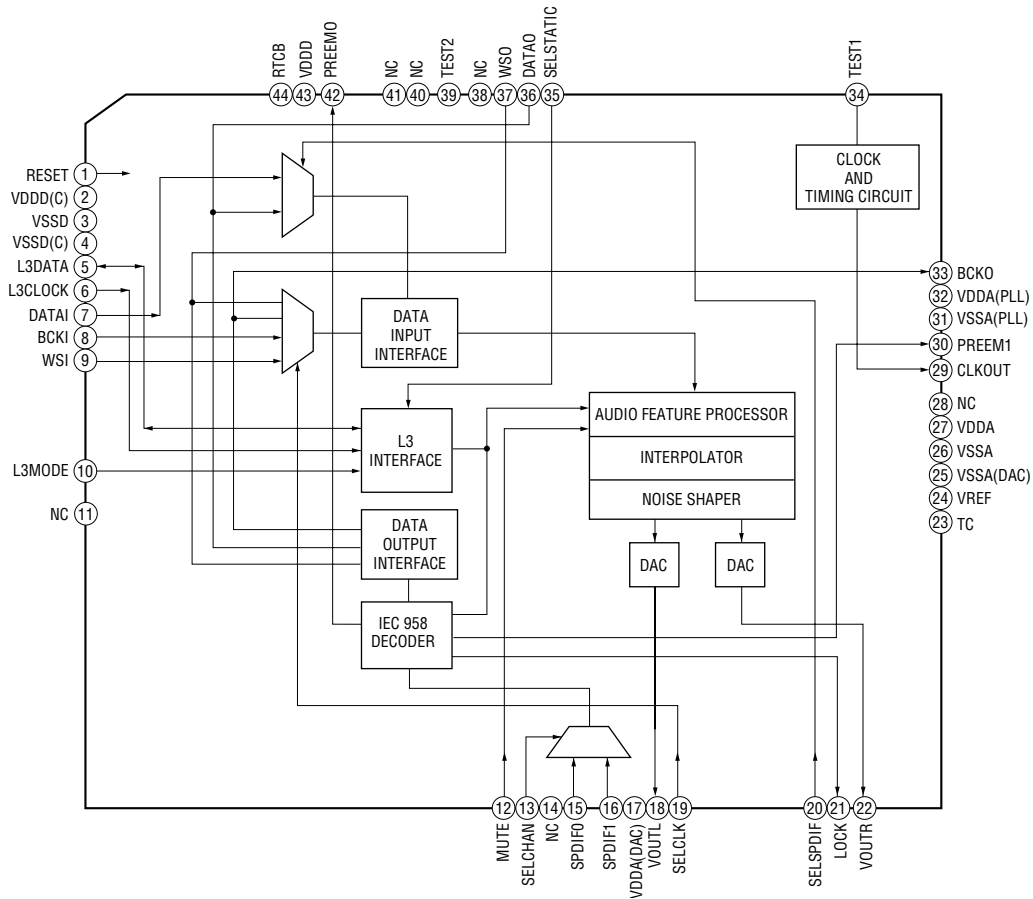

6-18. IC PIN FUNCTIONS

• IC101 CXD3008Q DIGITAL SIGNAL PROCESSOR (BD (CD) Board)

Pin No.	Pin Name	I/O	Function
1	DVDD0	—	Digital power supply
2	XRST	I	System reset
3	MUTE	I	Muting selection pin
4	DATA	I	Serial data input, supplied from CPU
5	XLAT	I	Latch input, supplied from CPU
6	CLOK	I	Serial data transfer clock input, supplied from CPU
7	SENS	O	SENS output
8	SCLK	I	SENS serial data read-out clock
9	ATSK	I/O	Input pin for anti-shock (Ground)
10	WFCK	O	WFCK (Write Frame Clock) output (Not used)
11	XUGF	O	XUGF output (Not used)
12	XPCK	O	XPCK output (Not used)
13	GFS	O	GFS output (Not used)
14	C2P0	O	C2PO output
15	SCOR	O	Sub-code sync output
16	CM4	O	4.2336MHz output (Not used)
17	WDCK	O	48-bit slot D/A interface word clock (Not used)
18	DVSS	—	Digital ground
19	COUT	O	Numbers of track counted signal output (Not used)
20	MIRR	O	Mirror signal output (Not used)
21	DFCT	O	Defect signal output (Not used)
22	FOK	O	Focus OK output (Not used)
23	PWM1	I	(Not used)
24	LOCK	I/O	GFS in sampled by 460Hz (Not used)
25	MDP	O	Output to control spindle motor servo
26	SSTP	I	Input signal to detect disc inner most trak
27	FST0	O	2/3 divider output (Not used)
28	DVDD1	—	Digital power supply
29	SFDR	O	Sled drive output
30	SRDR	O	
31	TFDR	O	Tracking drive output
32	TRDR	O	
33	FFDR	O	Focus drive output
34	FRDR	O	
35	DVSS1	—	Digital ground
36	TEST	I	TEST pin connected normally ground
37	TES1	I	
38	VC	I	Center voltage input
39	FE	I	FOCUS error signal input
40	SE	I	Sled error signal input

Pin No.	Pin Name	I/O	Function
41	TE	I	Tracking error signal input
42	CE	I	Center servo analog input
43	RFDC	I	RF signal input
44	ADI0	O	Test pin (Not used)
45	AVSS0	—	Analog ground
46	IGEN	I	Power supply pin operational amplifiers
47	AVDD	—	Analog power supply
48	ASYO	O	EFM full swing output
49	ASYI	I	Asymmetry compare voltage input
50	RFAC	I	EFM signal input
51	AVSS1	—	Analog ground
52	CLTV	I	Control voltage input for master VCO
53	FILO	O	Filter output for master PLL
54	FILI	I	Filter input for master PLL
55	PCO	O	Charge-pump output for master PLL
56	AVDD1	—	Analog power supply
57	BIAS	I	Asymmetry circuit constant current input
58	VCTL	I	Control voltage input for variable pitch PLL
59	V16M	I/O	16.9344MHz output (Not used)
60	VPCO	O	Charge-pump output for variable pitch PLL (Not used)
61	DVDD2	—	Digital power supply
62	ASYE	I	Asymmetry circuit ON/OFF (Connected to +5V.)
63	MD2	I	Digital-out ON/OFF control (Connected to +5V.)
64	DOUT	O	Digital-out output
65	LRCK	O	48-bit slot D/A interface, LR clock output
66	PCMD	O	48-bit slot D/A interface, Serial data output
67	BCLK	O	48-bit slot D/A interface, bit clock output
68	EMPH	O	Playback disc output in emphasis mode (Not used)
69	XTSL	I	X'tal selection input pin
70	DVSS2	—	Digital ground
71	XTAI	I	X'tal oscillator circuit input
72	XTAO	O	X'tal oscillator circuit output (Not used)
73	SOUT	O	(Not used)
74	SOCK	O	
75	XOCT	O	
76	SQSO	O	Sub-Q serial output
77	SQCK	I	Clock input for SQSO read-out
78	SCSY	I	Sub-code input
79	SBSO	O	Sub-P through Sub-W serial output (Not used)
80	EXCR	I	Clock input for SBSO read-out

• IC101 CXA2523AR RF Amplifier (BD (MD) BOARD)

Pin No.	Pin Name	I/O	Function
1	I	I	I-V converted RF signal I input
2	J	I	I-V converted RF signal J input
3	VC	O	Middle point voltage (+1.5V) generation output
4 to 9	A to F	I	Signal input from the optical pick-up detector
10	PD	I	Light amount monitor input
11	APC	O	Laser APC output
12	APCREF	I	Reference voltage input for setting laser power
13	GND	—	Ground
14	TEMPI	I	Temperature sensor connection
15	TEMPR	O	Reference voltage output for the temperature sensor
16	SWDT	I	Serial data input from the CXD2662R
17	SCLK	I	Serial clock input from the CXD2662R
18	XLAT	I	Latch signal input from the CXD2662R “L”: Latch
19	XSTBY	I	Stand by signal input “L”: Stand by
20	FOCNT	I	Center frequency control voltage input of BPF22, BPF3T, EQ from the CXD2662R
21	VREF	O	Reference voltage output (Not used)
22	EQADJ	I/O	Center frequency setting pin for the internal circuit EQ
23	3TADJ	I/O	Center frequency setting pin for the internal circuit BPF3T
24	Vcc	—	+3V power supply
25	WBLADJ	I/O	Center frequency setting pin for the internal circuit BPF22
26	TE	O	Tracking error signal output to the CXD2662R
27	CSLED	—	External capacitor connection pin for the sled error signal LPF
28	SE	O	Sled error signal output to the CXD2662R
29	ADFM	O	FM signal output of ADIP
30	ADIN	I	ADIP signal comparator input ADFM is connected with AC coupling
31	ADAGC	—	External capacitor connection pin for AGC of ADIP
32	ADFG	O	ADIP duplex signal output to the CXD2662R
33	AUX	O	I3 signal/temperature signal output to the CXD2662R (Switching with a serial command)
34	FE	O	Focus error signal output to the CXD2662R
35	ABCD	O	Light amount signal output to the CXD2662R
36	BOTM	O	RF/ABCD bottom hold signal output to the CXD2662R
37	PEAK	O	RF/ABCD peak hold signal output to the CXD2662R
38	RF	O	RF equalizer output to the CXD2662R
39	RFAGC	—	External capacitor connection pin for the RF AGC circuit
40	AGCI	I	Input to the RF AGC circuit The RF amplifier output is input with AC coupling
41	COMPO	O	User comparator output (Not used)
42	COMPP	I	User comparator input (Fixed at “L”)
43	ADDC	I/O	External capacitor pin for cutting the low band of the ADIP amplifier
44	OPO	O	User operation amplifier output (Not used)
45	OPN	I	User operation amplifier inversion input (Fixed at “L”)
46	RFO	O	RF amplifier output
47	MORFI	I	Groove RF signal is input with AC coupling
48	MORFO	O	Groove RF signal output

• Abbreviation

APC: Auto Power Control

AGC: Auto Gain Control

• IC151 CXD2662R Digital Signal Processor, Digital Servo Signal Processor (BD (MD) BOARD)

Pin No.	Pin Name	I/O	Function
1	MNT0 (FOK)	O	FOK signal output to the system control (monitor output) “H” is output when focus is on
2	MNT1 (SHCK)	O	Track jump detection signal output to the system control (monitor output)
3	MNT2 (XBUSY)	O	Monitor 2 output to the system control (monitor output)
4	MNT3 (SLOC)	O	Monitor 3 output to the system control (monitor output)
5	SWDT	I	Writing data signal input from the system control
6	SCLK	I (S)	Serial clock signal input from the system control
7	XLAT	I (S)	Serial latch signal input from the system control
8	SRDT	O (3)	Reading data signal output to the system control
9	SENS	O (3)	Internal status (SENSE) output to the system control
10	XRST	I (S)	Reset signal input from the system control “L”: Reset
11	SQSY	O	Subcode Q sync (SCOR) output to the system control “L” is output every 13.3 msec. Almost all, “H” is output
12	DQSY	O	Digital In U-bit CD format or MD format subcode Q sync (SCOR) output to the system control
13	RECP	I	Laser power switching input from the system control “H”: Recording, “L”: Playback
14	XINT	O	Interrupt status output to the system control
15	TX	I	Recording data output enable input from the system control
16	OSCI	I	System clock input (512Fs=22.5792 MHz)
17	OSCO	O	System clock output (512Fs=22.5792 MHz) (Not used)
18	XTSL	I	System clock frequency setting “L”: 45.1584 MHz, “H”: 22.5792 MHz (Fixed at “H”)
19	DIN0	I	Digital audio input (Optical input)
20	DIN1	I	Digital audio input (Optical input)
21	DOUT	O	Digital audio output (Optical output)
22	DADTI	I	Serial data input
23	LRCKI	I	LR clock input “H” : Lch, “L” : R ch
24	XBCKI	I	Serial data clock input
25	ADDT	I	Data input from the A/D converter
26	DADT	O	Data output to the D/A converter
27	LRCK	O	LR clock output for the A/D and D/A converter (44.1 kHz)
28	XBCK	O	Bit clock output to the A/D and D/A converter (2.8224 MHz)
29	FS256	O	11.2896 MHz clock output (Not used)
30	DVDD	—	+3V power supply (Digital)
31 to 34	A03 to A00	O	DRAM address output
35	A10	O	DRAM address output (Not used)
36 to 40	A04 to A08	O	DRAM address output
41	A11	O	DRAM address output (Not used)
42	DVSS	—	Ground (Digital)
43	XOE	O	Output enable output for DRAM
44	XCAS	O	CAS signal output for DRAM
45	A09	O	Address output for DRAM
46	XRAS	O	RAS signal output for DRAM
47	XWE	O	Write enable signal output for DRAM
48	D1	I/O	Data input/output for DRAM
49	D0	I/O	
50, 51	D2, D3	I/O	
52	MVCI	I (S)	Clock input from an external VCO (Fixed at “L”)
53	ASYO	O	Playback EFM duplex signal output
54	ASYI	I (A)	Playback EFM comparator slice level input
55	AVDD	—	+3V power supply (Analog)

* I (S) stands for Schmidt input, I (A) for analog input, O (3) for 3-state output, and O (A) for analog output in the column I/O

Pin No.	Pin Name	I/O	Function
56	BIAS	I (A)	Playback EFM comparator bias current input
57	RFI	I (A)	Playback EFM RF signal input
58	AVSS	—	Ground (Analog)
59	PCO	O (3)	Phase comparison output for the recording/playback EFM master PLL
60	FILI	I (A)	Filter input for the recording/playback EFM master PLL
61	FILO	O (A)	Filter output for the recording/playback EFM master PLL
62	CLTV	I (A)	Internal VCO control voltage input for the recording/playback EFM master PLL
63	PEAK	I (A)	Light amount signal peak hold input from the CXA2523AR
64	BOTM	I (A)	Light amount signal bottom hold input from the CXA2523AR
65	ABCD	I (A)	Light amount signal input from the CXA2523AR
66	FE	I (A)	Focus error signal input from the CXA2523AR
67	AUX1	I (A)	Auxiliary A/D input
68	VC	I (A)	Middle point voltage (+1.5V) input from the CXA2523AR
69	ADIO	O (A)	Monitor output of the A/D converter input signal (Not used)
70	AVDD	—	+3V power supply (Analog)
71	ADRT	I (A)	A/D converter operational range upper limit voltage input (Fixed at "H")
72	ADRB	I (A)	A/D converter operational range lower limit voltage input (Fixed at "L")
73	AVSS	—	Ground (Analog)
74	SE	I (A)	Sled error signal input from the CXA2523AR
75	TE	I (A)	Tracking error signal input from the CXA2523AR
76	DCHG	I (A)	Connected to +3V power supply
77	APC	I (A)	Error signal input for the laser digital APC (Fixed at "L")
78	ADFG	I (S)	ADIP duplex FM signal input from the CXA2523AR (22.05 ± 1 kHz)
79	F0CNT	O	Filter f0 control output to the CXA2523AR
80	XLRF	O	Control latch output to the CXA2523AR
81	CKRF	O	Control clock output to the CXA2523AR
82	DTRF	O	Control data output to the CXA2523AR
83	APCREF	O	Reference PWM output for the laser APC
84	TEST0	O	PWM output for the laser digital APC (Not used)
85	TRDR	O	Tracking servo drive PWM output (-)
86	TFDR	O	Tracking servo drive PWM output (+)
87	DVDD	—	+3V power supply (Digital)
88	FFDR	O	Focus servo drive PWM output (+)
89	FRDR	O	Focus servo drive PWM output (-)
90	FS4	O	176.4 kHz clock signal output (X'tal) (Not used)
91	SRDR	O	Sled servo drive PWM output (-)
92	SFDR	O	Sled servo drive PWM output (+)
93	SPRD	O	Spindle servo drive PWM output (-)
94	SPFD	O	Spindle servo drive PWM output (+)
95	FGIN	I (S)	Test input (Fixed at "L")
96 to 98	TEST1 to TEST3	I	
99	DVSS	—	Ground (Digital)
100	EFMO	O	EFM output when recording

- Abbreviation

EFM: Eight to Fourteen Modulation

PLL : Phase Locked Loop

VCO: Voltage Controlled Oscillator

• IC1001 M30805SGP SYSTEM CONTROL (DIGITAL BOARD)

Pin No.	Pin Name	I/O	Function
1	—————	—	Not used.
2	—————	—	Not used.
3	LVLI	—	Not used.
4	LVLO	—	Not used.
5	(TXD3)	—	Not used.
6	(RXD3)	—	Not used.
7	(CLK3)	—	Not used.
8	MUTE	O	Line out muting output. L: Mute
9	DARST	O	Reset signal output to the D/A converter. L: Active
10	SLICERSEL	O	IEC958 input select signal output to the D/A converter. L: CD H: MD
11	LD-LOW	O	Loading motor voltage control output L: High voltage H: Low voltage
12	LDIN	I	Loading motor control input. H: IN
13	LDOUT	O	Loading motor control output. H: OUT
14	MOD	O	Laser modulation switching signal output. L: OFF H: ON
15	BYTE	I	Data bus changed input. (Connected to ground.)
16	CNVSS	—	Ground.
17	X-CIN	O	Sub clock input. (32.768kHz) (Not used.)
18	X-COUT	O	Sub clock output. (32.768kHz) (Not used.)
19	$\overline{\text{RESET}}$	I	System rest input. L : ON
20	XOUT	O	Main clock output. (10MHz)
21	VSS0	—	Ground.
22	XIN	I	Main clock input. (10MHz)
23	VCC0	—	Power supply. (+3.3V)
24	$\overline{\text{NMI}}$	I	Fixed at H. (Pull-up)
25	DQSY	I	Digital in sync input. (Record system)
26	P.DOWN	I	Power down detection input. L: Power down
27	SQSY	I	ADIP (MO) sync or subcode Q (PIT) sync input from CXD2662R.(Playback system)
28	NC	—	Not used.
29	LDON	O	Laser ON/OFF control output. H: Laser ON
30	LIMIT-IN	I	Detection input from the limit switch. L: Sled limit-In H: Sled limit-Out
31	C2-PWM-B	—	Not used.
32	XINIT	I	Interrupt status input from CXD2662R.
33	—————	—	Not used.
34	XELT	I	XELT input from DSP IC.
35	WR PWR	O	Write power ON/OFF output. L: OFF H: ON
36	IIC CLK	I/O	IIC serial clock input/output.
37	IIC DATA	I/O	IIC serial data input/output.
38	SWDT	O	Writing data signal output to the serial bus.
39	VCC1	—	Power supply. (+3.3V)
40	SRDT	I	Reading data signal input from the serial bus.
41	VSS1	—	Ground.
42	SCLK	O	Clock signal output to the serial bus.
43	REC-SW	I	Detection signal input from the recording position detection switch. L: REC
44	CLIP DTO	O	CLIP serial data output.
45	CLIPDTI	I	CLIP serial data input. (Not used.)
46	CLIP CLK	O	CLIP serial clock output. (Not used.)
47	DIG-RST	O	Digital rest signal output to the CXD2662R and motor driver. L: Reset
48	SENS	I	Internal status (SENSE) input from the CXD2662R.
49	PLAY-SW	I	Detection signal input from the playback position detection switch. L: PLAY
50	XLAT	O	Latch signal output to DSP IC.
51	OUT-SW	I	Detection signal input from the loading out detection switch.
52	—————	—	Not used.

Pin No.	Pin Name	I/O	Function
53	————	—	Not used.
54	————	—	Not used.
55	————	O	Not used.
56	MNT2 (XBUSY)	I	In the state of executive command from the CXD2662R
57	VSS2	—	Ground.
58	MNT1 (SHCK)	I	Track jump signal input from the CXD2662R
59	VCC2	—	Power supply. (+3.3V)
60	EEP-WP	O	EEP-ROM write protect signal output. L: write possibility
61	SDA (EEP)	I/O	Data signal input/output pin with the EEPROM.
62	BCLK/ALE/CLKO	—	Not used.
63	$\overline{RD}/\overline{DW}$	O	Read signal output.
64	$\overline{BHE}/\overline{CASH}$	—	Not used.
65	$\overline{WR}/\overline{CASL}$	O	Write signal output.
66	SCL	O	Clock signal output to the EEPROM.
67	REFLECT	I	Disk reflection rate detection input from the reflect detection switch. H: Disk with low reflection rate
68	PROTECT	I	Recording-protection claw detection input from the protection detection switch. H: Protect
69	$\overline{CS0}$	O	Chip select signal output to the Flash ROM.
70	$\overline{CS1}$	O	Not used.
71	————	O	Not used.
72	A20	O	Address bus signal output to Flash ROM.
73	A19	O	Address bus signal output to Flash ROM.
74	VCC3	—	Power supply. (+3.3V)
75	A18	O	Address bus signal output to Flash ROM.
76	VSS3	—	Ground
77 to 85	A17 to A9	O	Address bus signal output to Flash ROM.
86 to 89	SEL 3 to 0	O	Not used.
90	WP	O	Write protect signal to the Flash ROM.
91	VCC4	—	Power supply. (+3.3V)
92	A8	O	Address bus signal output to Flash ROM.
93	VSS4	—	Ground.
94 to 100	A7 to A1	O	Address bus signal output to Flash ROM.
101	\overline{LB}	—	Not used.
102 to 113	D15 to D4	I/O	Data bus signal input/output to the Flash ROM.
114	CLIP-SEL	O	Not used.
115	IIC BUSY	O	IIC cable connect check. L: Active
116	DALOCK	O	LOCK signal input from D/A converter.
117	LINE-MUTE	O	Not used.
118	ADP DOWN	O	Reset signal output to the A/D converter.
119 to 122	D3 to D0	I/O	Data bus signal input/output to the Flash ROM.
123	SPDIF-CUT	—	Jog dial pulse input from the rotary encoder.
124	OPT SEL	O	Optical select signal output.
125 to 129	————	—	Not used.
130	VSS5	—	Ground.
131	————	O	Not used.
132	VCC5	—	Power supply. (+3.3V)
133	OP-LEVEL	I	Optical Pick-up voltage (current) detect signal input.
134 to 139	————	—	Not used.
140	AVSS	—	Ground. (Analog)
141	————	—	Not used.
142	VREF	—	Power supply. (+3.3V)
143	AVCC	—	Power supply. (+3.3V)
144	NC	I	Not used.

• IC101 M30620MCA-A41FP MASTER CONTROL (MAIN BOARD)

Pin No.	Pin Name	I/O	Descriptions
1	CD DATA	O	CD data output
2	CD CLK	O	CD clock output
3	XLT	O	CD latch signal output
4	ACCUT	I	AC cut input L=ON, H=OFF
5	NO USE	—	Not used.
6	SQ DATA IN	I	Subcode Q data input
7	SQ CLK	I	Subcode Q data input
8	BYTE	—	Connected to ground
9	CNVSS	—	Vss help down for FLASH connector
10	CD HOLD	O	CD LASER power control output
11	SENSE	I	CD SENSOR input
12	RESET	I	System reset input
13	X-OUT	O	MAIN SYSTEM CLOCK output (16MHz)
14	VSS	—	Connected to ground
15	X-IN	I	MAIN SYSTEM CLOCK input (16MHz)
16	VDD	—	Power supply (+5V)
17	NMI	I	PULL UP (EVER +5V)
18	WAKE UP	I	WAKE UP signal input (L)
19	SCOR	I	CD Q-data request signal input
20 to 23	NO USE	—	Not used.
24	LINE-MUTE	—	Not used.
25	LD-ON	O	CD LASER ON
26	MD-RST	—	Not used.
27	DA-MTTE	O	DA mute signal output L=ON, H=OFF
28	POWER DOWN	O	MD power down output
29	IIC-CLK	O	IIC SCL output
30	IIC-DATA	O	IIC SDA output
31	TXD1	O	Write data output for FLASH connector
32	RXD1	I	Read data input for FLASH connector
33	CLK1	I	Clock data input for FLASH connector
34	RTS1	O	Write data output for FLASH connector
35	LCD DATA	O	LCD data output
36	NO USE	—	Not used.
37	LCD CLK	O	LCD driver clock output
38	LCD LATCH	O	LCD driver latch output
39	LCD RESET	O	LCD reset signal output
40	LCD A0	O	LCD A0 signal output
41	XHOLD	I	Vss help down for FLASH connector
42	LCD SW	O	LCD power L=ON, H=OFF
43	X1 X2	O	Speed selector
44, 45	NO USE	—	Not used.
46	XWR	I	Vcc help up for FLASH connector
47	LED A1	O	LED drive signal output of the DISC1 indicator
48	LED A2	O	LED drive signal output of the DISC2 indicator
49	LED A3	O	LED drive signal output of the DISC3 indicator
50	LED A4	O	LED drive signal output of the DISC4 indicator
51	LED A5	O	LED drive signal output of the DISC5 indicator
52	LED CD PLAY	—	Not used.

Pin No.	Pin Name	I/O	Descriptions
53	LED CD PAUSE	—	Not used.
54	LED MD PLAY	—	Not used.
55	LED MD PAUSE	—	Not used.
56	LED NORMAL	—	Not used.
57	LED HIGH	—	Not used.
58	LED LCD	O	LED drive signal output of the LCD indicator
59	NO USE	—	Not used.
60	FAN CTRL	—	Not used.
61	LED ON/OFF	O	Power ON/OFF control signal output of the key illumination LED
62	VDD	—	Power supply (+5V)
63	CD POWER	O	CD power H=ON, L=OFF
64	VSS	—	Connected to ground
65	JOG-A	I	JOG A (Rotary encoder) control input
66	JOG-B	I	JOG B (Rotary encoder) control input
67	NO USE	—	Not used.
68	SOFT MODE1	O	Destination setting terminal (normally: fixed at “L”)
69	SOFT MODE0	O	Destination setting terminal (normally: fixed at “L”)
70	CD ADJ	I	Setting terminal for the CD test mode
71	AMUTE	—	Not used.
72	SPDIF MUTE	—	Not used.
73	LDP-POS	O	CD loading motor control signal output
74	LDP-NEG	O	CD loading motor control signal output
75	OUT SW	I	Detection input from the tray open/close detect switch on the CD mechanism block
76	MIDOUT SW	I	Detection input from the mid out detect switch on the CD mechanism block
77	IN SW	I	Detection input from the tray open/close detect switch on the CD mechanism block
78	MIDIN SW	I	Detection input from the mid out detect switch on the CD mechanism block
79	CLP-POS	O	CD elevator up/down motor control signal output
80	CLP-NEG	O	CD elevator up/down motor control signal output
81	INT SW	I	Detection input from the INT detection switch on the CD mechanism block
82	CNT-SW	I	Detection input from the count detect switch on the CD mechanism block
83	ENC 2	I	Detection input from the disc tray address detect rotary encoder on the CD mechanism block
84	ENC 1	I	Detection input from the disc tray address detect rotary encoder on the CD mechanism block
85	ENC 0	I	Detection input from the disc tray address detect rotary encoder on the CD mechanism block
86	DISC SENS	I	Detection input from the disc in detect sensor on the CD mechanism block
87	PRTC SW	I	Detection input from the CD tray door open/close detect switch
88	SOFT TEST	—	Not used.
89	NO USE	—	Not used.
90	MODEL IN	—	Not used.
91	KEY 1	I	Key input terminal (A/D input)
92	KEY 0	I	Key input terminal (A/D input)
93	SPEC IN	—	Not used.
94	LVL-L	—	Connected to ground
95	LVL-R	—	Connected to ground
96	AVSS	—	Connected to ground
97	TRK-ERR	—	Not used.
98	VREF	I	Analog Reference Voltage
99	AVCC	—	Analog Power supply
100	XRST	O	CD reset signal output

SECTION 7 EXPLODED VIEWS

NOTE:

- -XX and -X mean standardized parts, so they may have some difference from the original one.
- Color Indication of Appearance Parts
Example:
KNOB, BALANCE (WHITE) . . . (RED)
 ↑ ↑
 Parts Color Cabinet's Color

- Items marked "*" are not stocked since they are seldom required for routine service. Some delay should be anticipated when ordering these items.
- The mechanical parts with no reference number in the exploded views are not supplied.
- Hardware (# mark) list is given in the last of the electrical parts list.

The components identified by mark Δ or dotted line with mark Δ are critical for safety. Replace only with part number specified.

- Abbreviation
MY : Malaysia model
SP : Singapore model
G : German model
AED : North European model

7-1. CASE, CHASSIS SECTION

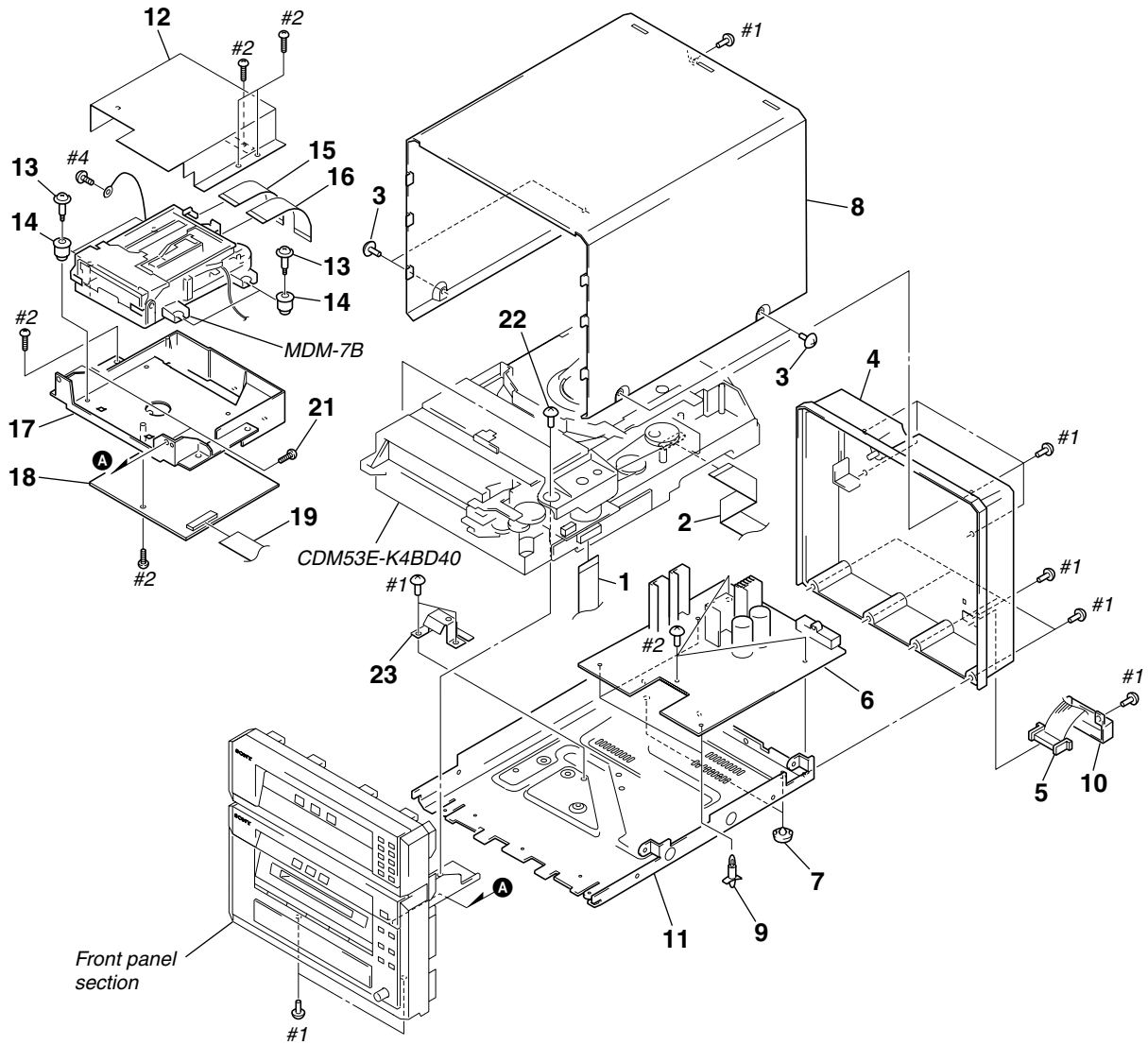

Ref. No.	Part No.	Description	Remark	Ref. No.	Part No.	Description	Remark
1	1-773-044-11	WIRE(FLAT TYPE) (17 CORE)		12	4-230-903-01	COVER (MD)	
2	1-791-433-11	WIRE(FLAT TYPE) (19 CORE)		13	4-228-684-01	SCREW (+BVTPWH M3), STEP	
3	3-363-099-11	SCREW(CASE 3 TP2)		14	4-228-689-11	INSULATOR	
4	4-228-328-01	PANEL, BACK		15	1-775-151-11	WIRE(FLAT TYPE) (17 CORE)	
5	1-791-075-21	CORD, CONNECTION		16	1-775-236-11	WIRE(FLAT TYPE) (27 CORE)	
6	A-4725-321-A	MAIN BOARD, COMPLETE(AEP,UK,G,AED,CIS)		17	4-228-332-01	HOLDER (MD)	
6	A-4725-326-A	MAIN BOARD, COMPLETE(MY,SP)		18	A-4725-324-A	DIGITAL BOARD, COMPLETE	
7	4-965-822-01	FOOT		19	1-773-233-11	WIRE(FLAT TYPE) (25 CORE)	
8	4-221-365-52	CASE		21	3-970-608-01	SUMITITE (B3), +BV	
* 9	4-924-098-51	HOLDER, PC BOARD		22	4-951-620-01	SCREW (2.6X8), +BVTP	
10	4-221-456-11	COVER (CONNECTOR)		23	4-228-333-01	BRACKET (MD)	
11	X-4952-657-4	CHASSIS ASSY					

7-2. FRONT PANEL SECTION

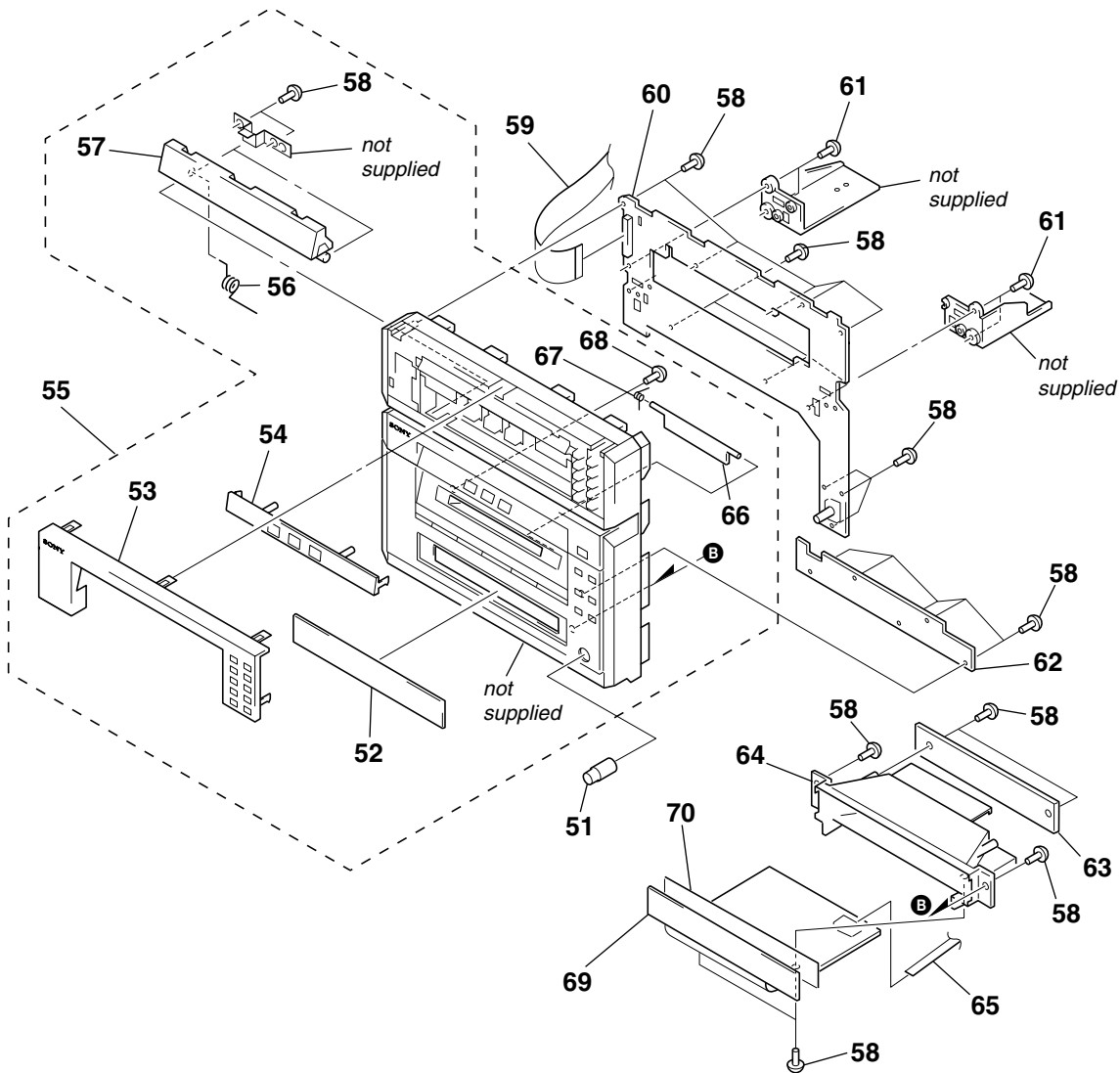

Ref. No.	Part No.	Description	Remark	Ref. No.	Part No.	Description	Remark
51	4-228-330-01	JOG(MD)		61	4-951-620-11	SCREW (2.6X10), +BVTP	
52	X-4952-956-1	WINDOW (MD) ASSY		62	1-678-225-11	REC BOARD	
53	4-221-432-31	PANEL (CD), SUB		63	1-678-226-11	BACK LIGHT BOARD	
54	4-221-430-01	COVER (CD)		64	4-228-331-01	HOLDER (LMD)	
55	X-4952-942-1	PANEL ASSY, FRONT		65	1-769-916-11	WIRE(FLAT TYPE) (9 CORE)	
56	4-221-451-02	SPRING (CD), TORSION		66	4-228-335-01	LID(MD)	
57	4-221-442-01	CDLID		67	4-228-323-01	SPRING (MD)	
58	4-951-620-01	SCREW (2.6X8), +BVTP		68	4-933-134-11	SCREW (+PTPWH M2.6X8)	
59	1-769-989-11	WIRE(FLAT TYPE) (13 CORE)		69	1-804-012-11	DISPLAY PANEL, LIQUID CRYSTAL	
60	A-4725-318-A	PANEL BOARD, COMPLETE		70	4-228-326-01	SHEET(MD), DIFFUSION	

**7-3. CD MECHANISM DECK SECTION-1
(CDM53E-K4BD40)**

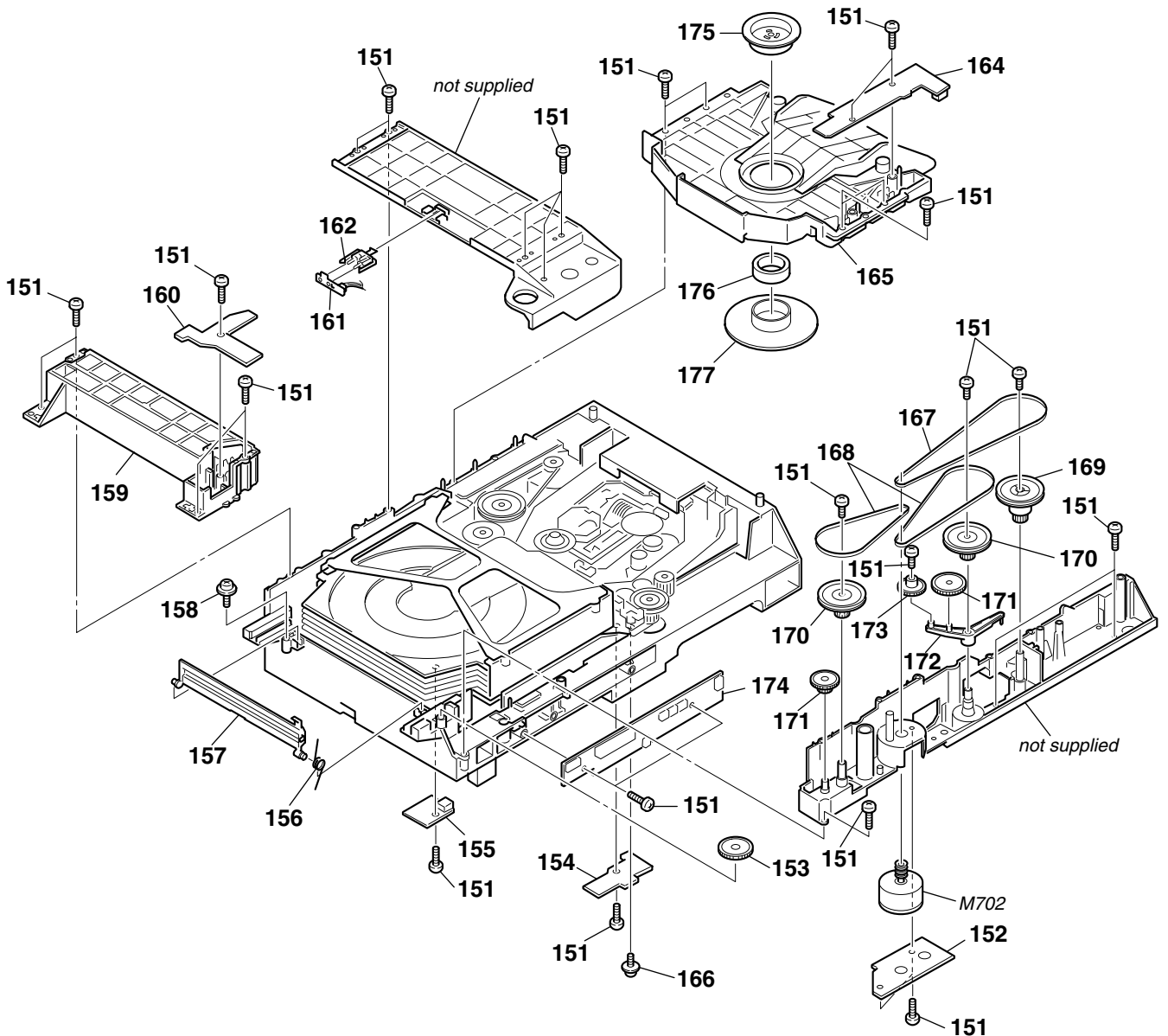

Ref. No.	Part No.	Description	Remark	Ref. No.	Part No.	Description	Remark
151	4-218-253-11	SCREW (M2.6), +BTTP		166	3-341-549-01	SCREW(2.6X12)(DIA.7.5),+PTP WH	
152	1-671-508-11	LOAD MOTOR BOARD		167	4-211-235-01	BELT (COMMUNICATION)	
153	4-211-215-01	GEAR (EJECT)		168	4-211-236-01	BELT (LOADING)	
154	1-671-502-11	INT/COUNT SW BOARD		169	4-211-231-01	PULLEY (MODE)	
155	1-671-504-11	SENSOR BOARD		170	4-211-214-01	PULLEY (LD)	
156	4-212-676-01	SPRING (LID), TORSION		171	4-211-232-01	GEAR (MODE DECELERATION)	
157	4-212-674-01	LID(DISC)		172	4-211-228-01	LEVER (GOOSENECK)	
158	4-985-672-01	SCREW (+PTPWH M2.6), FLOATING		173	4-214-130-01	GEAR (TRAY)	
159	A-4672-873-A	BASE (GUIDE) ASSY, FITTING		174	1-671-506-11	CONNECTOR BOARD	
160	1-671-503-11	OUT SW BOARD		175	4-225-368-01	PULLEY (C), CHUCKING	
161	1-671-789-11	SENSOR 2 BOARD		176	1-471-061-11	MAGNET ASSY	
162	4-964-461-02	HOLDER (SENSOR)		177	X-4952-936-1	PULLEY (A) ASSY, CHUCKING	
164	1-671-505-11	IN SW BOARD		M702	X-4950-342-1	MOTOR (LOADING) ASSY	
165	A-4672-872-D	BASE (MAGNET) ASSY, FITTING					

**7-4. CD MECHANISM DECK SECTION-2
(CDM53E-K4BD40)**

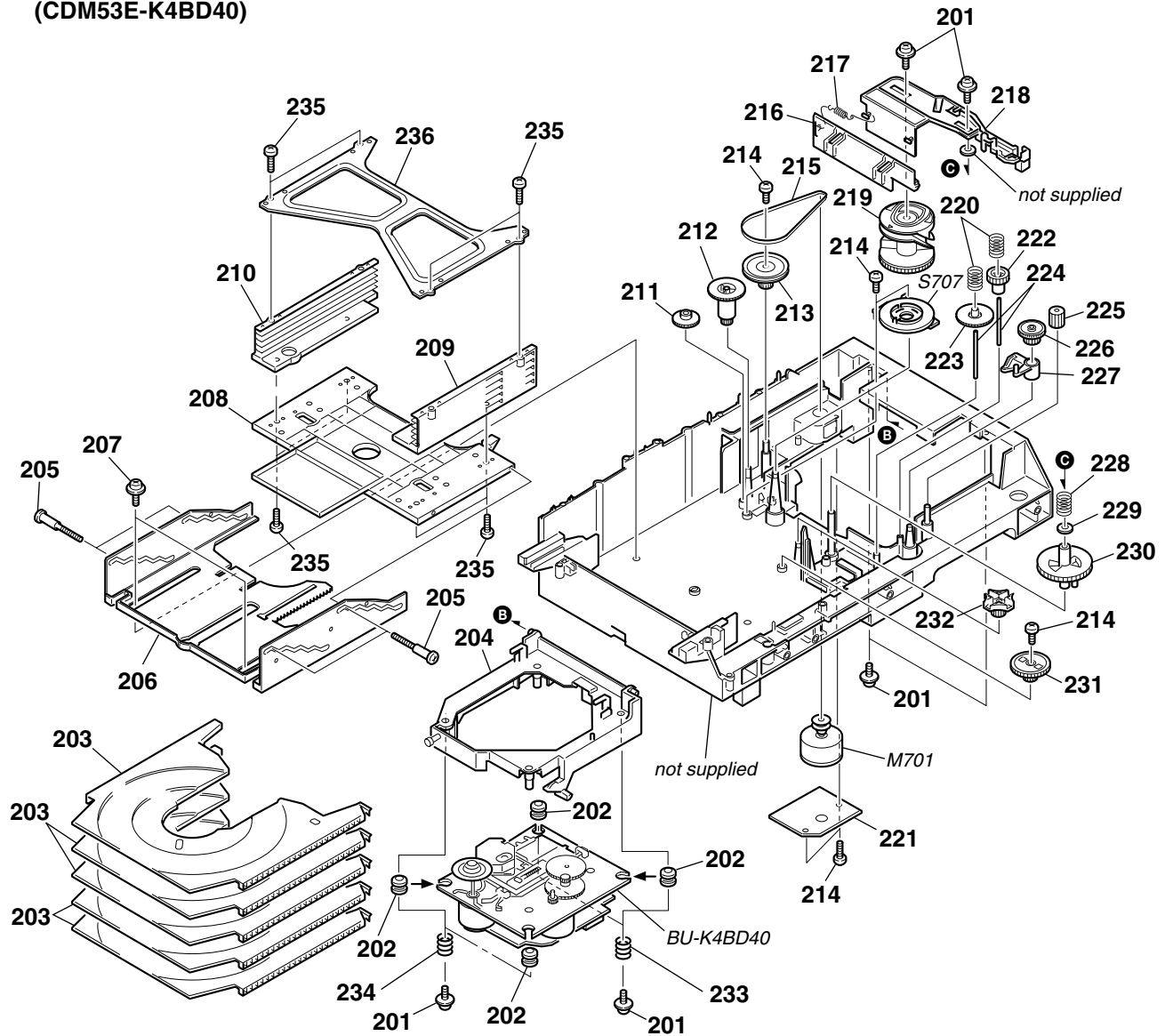

Ref. No.	Part No.	Description	Remark	Ref. No.	Part No.	Description	Remark
201	4-985-672-01	SCREW (+PTPWH M2.6), FLOATING		221	1-671-507-11	CLAMP MOTOR BOARD	
202	4-220-933-01	INSULATOR		222	4-211-221-01	GEAR (LD MOVABLE)	
203	4-211-212-51	TRAY (SUB)		223	4-211-217-01	GEAR (SELECTION)	
204	X-4950-322-3	HOLDER (BU) ASSY		224	4-211-242-11	SHAFT (SELECTION GEAR)	
205	4-211-244-01	SCREW, STEP		225	4-211-240-01	GEAR (LD DECELERATION B)	
206	4-211-223-01	SLIDER (U/D)		226	4-211-216-01	GEAR (RELAY)	
207	4-933-134-01	SCREW (M2.6), +PTPWH		227	3-701-446-21	WASHER	
208	4-221-504-01	BASE (STOCKER), FITTING		227	4-211-241-01	LEVER (SELECTION)	
209	4-211-211-01	STOCKER (R)		228	4-216-879-01	SPRING (GEAR), COMPRESSION	
210	4-211-210-01	STOCKER (L)		230	4-211-218-01	GEAR (GEAR A)	
211	4-211-215-01	GEAR (EJECT)		231	4-211-220-01	GEAR (U/D SLIDER)	
212	4-211-232-01	GEAR (LD DECELERATION)		232	4-211-219-01	GEAR (GEAR B)	
213	4-211-214-01	PULLEY (LD)		233	4-222-784-01	SPRING (INSULATOR), COMPRESSION	
214	4-218-253-31	SCREW (M2.6), +BTTP		234	4-222-785-01	SPRING (INSULATOR), COMPRESSION	
215	4-211-237-01	BELT (MODE)		235	4-218-253-21	SCREW (M2.6), +BTTP	
216	4-212-677-01	SLIDER (SHUTTER)		236	4-211-234-01	BRACKET (STOCKER T)	
217	4-212-678-01	SPRING (SHUTTER), TENSION		M701	X-4950-341-1	MOTOR (CLAMP) ASSY	
218	4-211-233-01	SLIDER (SELECTION)		S707	1-418-045-11	ENCODER, ROTARY(DISC TRAY ADDRESS)	
219	4-211-230-01	GEAR (CHUCKING)					(DET)
220	4-211-245-01	SPRING, COMPRESSION					

**7-5. CD BASE UNIT SECTION
(BU-K4BD40)**

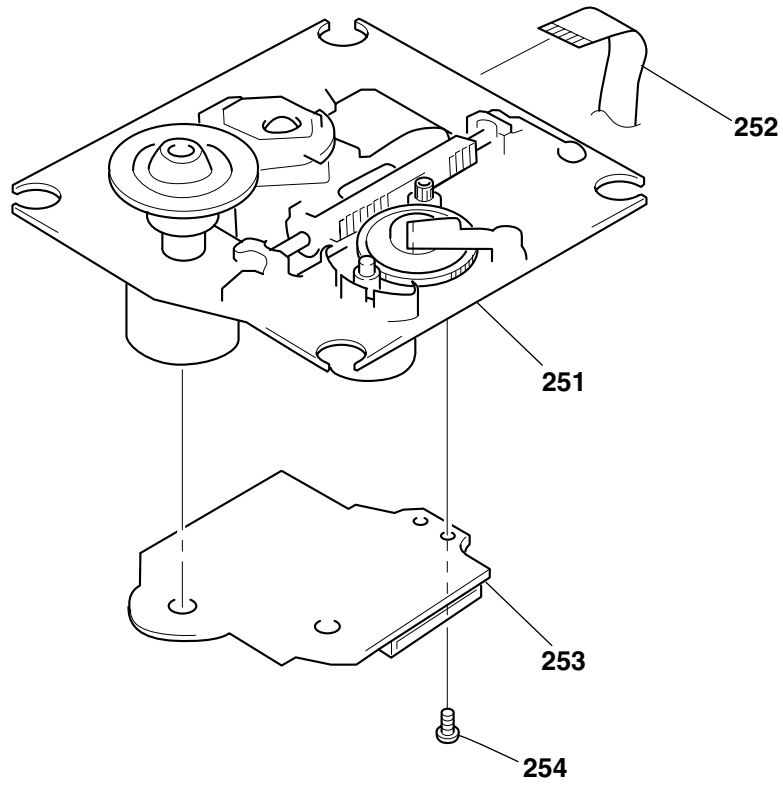

The components identified by mark \triangle or dotted line with mark \triangle are critical for safety. Replace only with part number specified.

<u>Ref. No.</u>	<u>Part No.</u>	<u>Description</u>	<u>Remark</u>	<u>Ref. No.</u>	<u>Part No.</u>	<u>Description</u>	<u>Remark</u>
\triangle 251	8-820-122-01	OPTICAL PICK-UP KSM-213DHAP/Z-NP		253	A-4725-108-A	BD(CD) BOARD, COMPLETE	
252	1-769-069-11	WIRE (FLAT TYPE) (16 CORE)		254	4-951-620-01	SCREW (2.6X8), +BVTP	

7-6. MD MECHANISM SECTION-1
(MDM-7B)

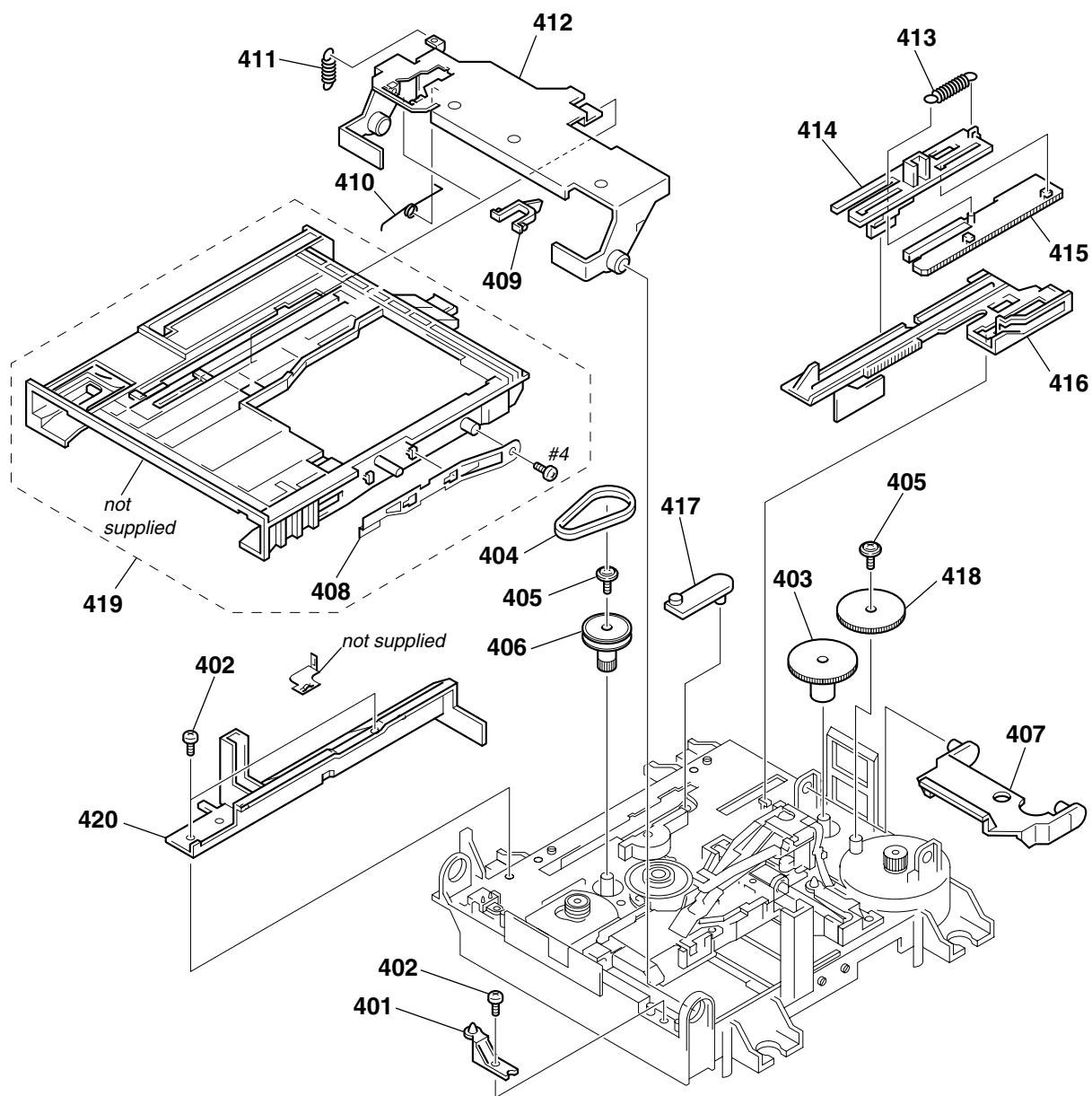

Ref. No.	Part No.	Description	Remark	Ref. No.	Part No.	Description	Remark
* 401	4-996-267-01	BASE (BU-D)		411	4-227-012-01	SPRING (HOLDER), TENSION	
402	4-908-618-21	SCREW (+BTP) (2X6)		412	4-227-019-02	PLATE (HOLDER), RETAINER	
403	4-227-007-01	GEAR (SB)		413	4-227-013-01	SPRING (EJ), TENSION	
404	4-227-025-01	BELT (LOADING)		414	4-226-995-01	SLIDER (EJ)	
405	3-372-761-01	SCREW (M1.7), TAPPING		415	4-226-996-01	LIMITTER (EJ)	
406	4-227-002-01	GEAR, PULLEY		416	4-226-997-01	SLIDER	
407	4-226-999-01	LEVER (HEAD)		417	4-226-998-01	LEVER (CHG)	
408	X-4952-665-1	SPRING (SHT) ASSY, LEAF		418	4-227-006-01	GEAR (SA)	
409	4-228-923-01	LOCK (HOLDER)		419	A-4673-973-A	HOLDER ASSY	
410	4-229-533-02	SPRING (STOPPER), TORSION		420	4-226-994-01	GUIDE (L)	

**7-7. MD MECHANISM SECTION-2
(MDM-7B)**

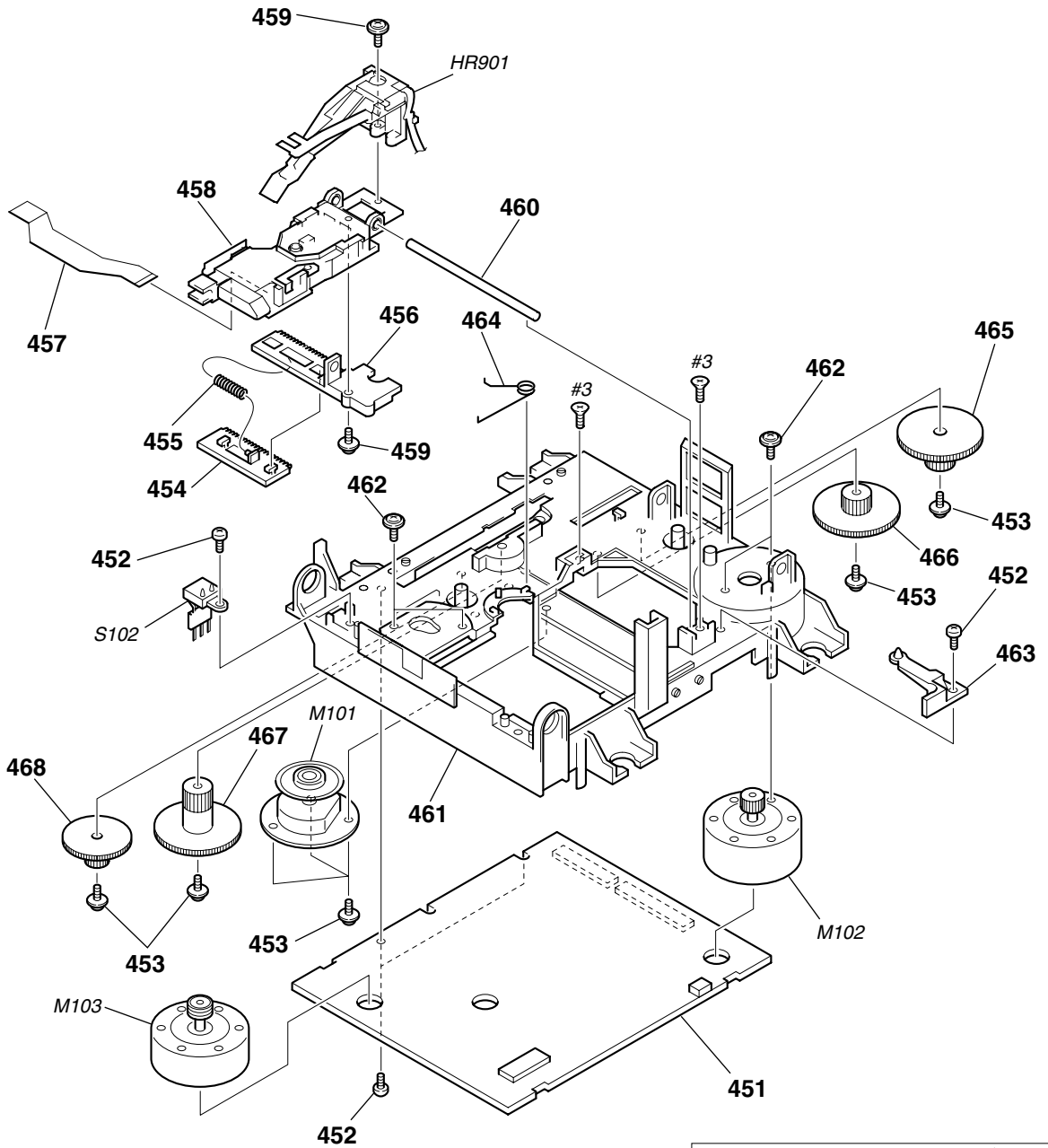

The components identified by mark \triangle or dotted line with mark \triangle are critical for safety. Replace only with part number specified.

Ref. No.	Part No.	Description	Remark	Ref. No.	Part No.	Description	Remark
451	A-4725-101-A	BD(MD) BOARD, COMPLETE		463	4-226-990-01	BASE (BU-A)	
452	4-908-618-21	SCREW (+BTP) (2X6)		464	4-227-023-01	SPRING (SPINDLE), TORSION	
453	3-372-761-01	SCREW (M1.7), TAPPING		465	4-227-004-01	GEAR (LC)	
454	4-226-993-01	RACK		466	4-227-005-01	GEAR (LD)	
455	4-227-014-01	SPRING (RACK), COMPRESSION		467	4-227-009-01	GEAR (SD)	
456	4-226-992-01	BASE, SL		468	4-227-008-01	GEAR (SC)	
457	1-678-514-11	FLEXIBLE BOARD		HR901	1-500-670-11	HEAD, OVER LIGHT	
\triangle 458	A-4672-541-A	OPTICAL PICK-UP KMS-260B/J1N		M101	A-4672-898-A	MOTOR ASSY, SPINDLE	
459	4-988-560-01	SCREW (+P 1.7X6)		M102	A-4672-900-A	MOTOR ASSY, SLED	
460	4-996-265-01	SHAFT, MAIN		M103	A-4672-975-A	MOTOR ASSY, LOADING	
461	4-226-989-01	CHASSIS		S102	1-771-957-11	SWITCH, PUSH (2 KEY)	
462	4-211-036-01	SCREW (1.7X2.5), +PWH					

Ref. No.	Part No.	Description			Remark	Ref. No.	Part No.	Description			Remark
R106	1-216-821-11	METAL CHIP	1K	5%	1/16W		A-4725-101-A	BD (MD) BOARD, COMPLETE			
R107	1-216-833-11	METAL CHIP	10K	5%	1/16W			*****			
R108	1-216-827-11	METAL CHIP	3.3K	5%	1/16W						
R109	1-216-857-11	METAL CHIP	1M	5%	1/16W			< CAPACITOR >			
R110	1-216-809-11	METAL CHIP	100	5%	1/16W						
R112	1-216-809-11	METAL CHIP	100	5%	1/16W		C101	1-135-259-11	TANTAL. CHIP	10uF	20.00% 6.3V
R118	1-216-829-11	METAL CHIP	4.7K	5%	1/16W		C102	1-135-259-11	TANTAL. CHIP	10uF	20.00% 6.3V
R119	1-216-813-11	METAL CHIP	220	5%	1/16W		C103	1-162-970-11	CERAMIC CHIP	0.01uF	10% 25V
R121	1-216-841-11	METAL CHIP	47K	5%	1/16W		C104	1-164-227-11	CERAMIC CHIP	0.022uF	10% 25V
R123	1-216-833-11	METAL CHIP	10K	5%	1/16W		C105	1-115-416-11	CERAMIC CHIP	1000PF	5.00% 25V
R124	1-216-845-11	METAL CHIP	100K	5%	1/16W		C106	1-162-970-11	CERAMIC CHIP	0.01uF	10% 25V
R131	1-216-813-11	METAL CHIP	220	5%	1/16W		C107	1-162-970-11	CERAMIC CHIP	0.01uF	10% 25V
R137	1-216-864-11	METAL CHIP	0				C108	1-162-969-11	CERAMIC CHIP	0.0068uF	10% 25V
R143	1-216-848-11	METAL CHIP	180K	5%	1/16W		C109	1-164-677-11	CERAMIC CHIP	0.033uF	10.00% 16V
R144	1-216-848-11	METAL CHIP	180K	5%	1/16W		C110	1-163-038-11	CERAMIC CHIP	0.1uF	25V
R145	1-216-857-11	METAL CHIP	1M	5%	1/16W		C111	1-117-720-11	CERAMIC CHIP	4.7uF	10V
R146	1-216-857-11	METAL CHIP	1M	5%	1/16W		C112	1-110-563-11	CERAMIC CHIP	0.068uF	10.00% 16V
R147	1-216-817-11	METAL CHIP	470	5%	1/16W		C113	1-162-968-11	CERAMIC CHIP	0.0047uF	10% 50V
R148	1-216-797-11	METAL CHIP	10	5%	1/16W		C114	1-125-837-91	CERAMIC CHIP	1uF	10% 6.3V
R149	1-216-798-11	RES-CHIP	12	5%	1/16W		C115	1-162-966-11	CERAMIC CHIP	0.0022uF	10% 50V
R150	1-216-833-11	METAL CHIP	10K	5%	1/16W		C116	1-164-227-11	CERAMIC CHIP	0.022uF	10% 25V
R152	1-216-833-11	METAL CHIP	10K	5%	1/16W		C117	1-162-970-11	CERAMIC CHIP	0.01uF	10% 25V
R154	1-216-809-11	METAL CHIP	100	5%	1/16W		C118	1-165-176-11	CERAMIC CHIP	0.047uF	10.00% 16V
R155	1-216-809-11	METAL CHIP	100	5%	1/16W		C119	1-165-176-11	CERAMIC CHIP	0.047uF	10.00% 16V
R156	1-216-809-11	METAL CHIP	100	5%	1/16W		C120	1-164-156-11	CERAMIC CHIP	0.1uF	25V
R157	1-216-809-11	METAL CHIP	100	5%	1/16W		C121	1-164-156-11	CERAMIC CHIP	0.1uF	25V
R158	1-216-833-11	METAL CHIP	10K	5%	1/16W		C125	1-117-720-11	CERAMIC CHIP	4.7uF	10V
R159	1-216-841-11	METAL CHIP	47K	5%	1/16W		C128	1-164-156-11	CERAMIC CHIP	0.1uF	25V
R162	1-216-847-11	METAL CHIP	150K	5%	1/16W		C131	1-117-720-11	CERAMIC CHIP	4.7uF	10V
R172	1-216-809-11	METAL CHIP	100	5%	1/16W		C132	1-164-156-11	CERAMIC CHIP	0.1uF	25V
R173	1-216-809-11	METAL CHIP	100	5%	1/16W		C133	1-164-156-11	CERAMIC CHIP	0.1uF	25V
R174	1-216-809-11	METAL CHIP	100	5%	1/16W		C141	1-126-206-11	ELECT CHIP	100uF	20% 6.3V
R180	1-216-845-11	METAL CHIP	100K	5%	1/16W		C142	1-164-156-11	CERAMIC CHIP	0.1uF	25V
R181	1-218-332-11	RES-CHIP	130K	5%	1/16W		C143	1-164-156-11	CERAMIC CHIP	0.1uF	25V
R182	1-216-837-11	METAL CHIP	22K	5%	1/16W		C144	1-162-970-11	CERAMIC CHIP	0.01uF	10% 25V
R183	1-216-837-11	METAL CHIP	22K	5%	1/16W		C145	1-164-156-11	CERAMIC CHIP	0.1uF	25V
R184	1-218-344-11	RES-CHIP	7.5K	5%	1/16W		C146	1-117-720-11	CERAMIC CHIP	4.7uF	10V
R185	1-218-344-11	RES-CHIP	7.5K	5%	1/16W		C147	1-117-720-11	CERAMIC CHIP	4.7uF	10V
R186	1-216-837-11	METAL CHIP	22K	5%	1/16W		C151	1-117-370-11	CERAMIC CHIP	10uF	10V
R187	1-216-837-11	METAL CHIP	22K	5%	1/16W		C152	1-164-156-11	CERAMIC CHIP	0.1uF	25V
R188	1-218-344-11	RES-CHIP	7.5K	5%	1/16W		C153	1-164-156-11	CERAMIC CHIP	0.1uF	25V
R189	1-218-344-11	RES-CHIP	7.5K	5%	1/16W		C154	1-126-206-11	ELECT CHIP	100uF	20% 6.3V
R190	1-216-837-11	METAL CHIP	22K	5%	1/16W		C155	1-164-156-11	CERAMIC CHIP	0.1uF	25V
R191	1-216-837-11	METAL CHIP	22K	5%	1/16W		C156	1-164-156-11	CERAMIC CHIP	0.1uF	25V
R192	1-218-344-11	RES-CHIP	7.5K	5%	1/16W		C157	1-164-156-11	CERAMIC CHIP	0.1uF	25V
R193	1-218-344-11	RES-CHIP	7.5K	5%	1/16W		C158	1-162-927-11	CERAMIC CHIP	100PF	5% 50V
		< SWITCH >					C159	1-162-927-11	CERAMIC CHIP	100PF	5% 50V
S101	1-771-853-11	SWITCH, DETECTION (LIMIT SW)					C160	1-162-927-11	CERAMIC CHIP	100PF	5% 50V
		< VIBRATOR >					C161	1-162-970-11	CERAMIC CHIP	0.01uF	10% 25V
X101	1-767-518-11	VIBRATOR, CRYSTAL (33.8688MHz)					C162	1-162-970-11	CERAMIC CHIP	0.01uF	10% 25V
		*****					C163	1-125-891-11	CERAMIC CHIP	0.47uF	10.00% 10V
							C164	1-162-927-11	CERAMIC CHIP	100PF	5% 50V
							C165	1-162-968-11	CERAMIC CHIP	0.0047uF	10% 50V
							C166	1-125-891-11	CERAMIC CHIP	0.47uF	10.00% 10V
							C167	1-164-245-11	CERAMIC CHIP	0.015uF	10.00% 25V
							C169	1-164-156-11	CERAMIC CHIP	0.1uF	25V
							C173	1-164-156-11	CERAMIC CHIP	0.1uF	25V
							C174	1-162-970-11	CERAMIC CHIP	0.01uF	10% 25V
							C180	1-117-370-11	CERAMIC CHIP	10uF	10V

BD (MD)

Ref. No.	Part No.	Description	Remark	Ref. No.	Part No.	Description	Remark
C181	1-126-206-11	ELECT CHIP 100uF	20% 6.3V	L161	1-500-245-11	INDUCTOR CHIP 0uH	
C182	1-163-038-11	CERAMIC CHIP 0.1uF	25V	L171	1-500-245-11	INDUCTOR CHIP 0uH	
C183	1-164-156-11	CERAMIC CHIP 0.1uF	25V	L180	1-469-855-21	FERRITE 0uH	
C184	1-117-970-11	ELECT CHIP 22uF	20.00% 10V	L181	1-469-855-21	FERRITE 0uH	
C185	1-131-872-91	CERAMIC CHIP 1000PF	10% 630V	L182	1-500-245-11	INDUCTOR CHIP 0uH	
C191	1-126-206-11	ELECT CHIP 100uF	20% 6.3V	L183	1-216-296-91	SHORT 0	
C192	1-164-156-11	CERAMIC CHIP 0.1uF	25V	L184	1-216-296-91	SHORT 0	
C193	1-126-206-11	ELECT CHIP 100uF	20% 6.3V	< TRANSISTOR >			
C194	1-164-156-11	CERAMIC CHIP 0.1uF	25V	Q101	8-729-403-35	TRANSISTOR UN5113-TX	
C195	1-164-156-11	CERAMIC CHIP 0.1uF	25V	Q121	8-729-403-35	TRANSISTOR UN5113-TX	
C196	1-164-156-11	CERAMIC CHIP 0.1uF	25V	Q122	8-729-101-07	TRANSISTOR 2SB798-T1DK	
C1401	1-117-720-11	CERAMIC CHIP 4.7uF	10V	Q131	8-729-026-53	TRANSISTOR 2SA1576A-T106-QR	
< CONNECTOR >				Q132	8-729-903-10	TRANSISTOR FMW1-T-148	
CN101	1-766-833-21	CONNECTOR, FFC/FPC (ZIF) 21P		Q133	8-729-402-93	TRANSISTOR UN5214-TX	
CN102	1-784-835-21	CONNECTOR, FFC (LIF (NON-ZIF)) 27P		Q134	8-729-402-93	TRANSISTOR UN5214-TX	
CN103	1-784-869-21	CONNECTOR, FFC (LIF (NON-ZIF)) 17P		Q181	8-729-018-75	TRANSISTOR 2SJ278MYTR	
* CN104	1-580-055-21	PIN, CONNECTOR (SMD) 2P		Q182	8-729-017-65	TRANSISTOR 2SK1764KYTR	
CN105	1-784-859-21	CONNECTOR, FFC (LIF (NON-ZIF)) 7P		< RESISTOR >			
< DIODE >				R101	1-216-829-11	METAL CHIP 4.7K	5% 1/16W
D101	8-719-988-61	DIODE 1SS355TE-17		R102	1-216-853-11	METAL CHIP 470K	5% 1/16W
D181	8-719-080-81	DIODE FS1J6		R103	1-216-863-11	RES-CHIP 3.3M	5% 1/16W
D183	8-719-080-81	DIODE FS1J6		R104	1-216-853-11	METAL CHIP 470K	5% 1/16W
< IC >				R105	1-216-825-11	METAL CHIP 2.2K	5% 1/16W
IC101	8-752-080-95	IC CXA2523AR		R106	1-216-825-11	METAL CHIP 2.2K	5% 1/16W
IC102	8-759-473-51	IC TLV2361CDBV		R107	1-216-825-11	METAL CHIP 2.2K	5% 1/16W
IC141	8-759-430-25	IC BH6511FS-E2		R108	1-216-833-11	METAL CHIP 10K	5% 1/16W
IC151	8-752-404-64	IC CXD2662R		R109	1-216-845-11	METAL CHIP 100K	5% 1/16W
IC152	8-759-599-51	IC MSM51V17400D-50TS-K		R110	1-216-845-11	METAL CHIP 100K	5% 1/16W
IC181	8-759-481-17	IC MC74ACT08DTR2		R111	1-216-833-11	METAL CHIP 10K	5% 1/16W
IC190	8-759-677-64	IC L88M35T		R112	1-216-829-11	METAL CHIP 4.7K	5% 1/16W
IC195	8-759-640-41	IC BR24C08F-E2		R113	1-216-833-11	METAL CHIP 10K	5% 1/16W
< JUMPER RESISTOR >				R114	1-216-827-11	METAL CHIP 3.3K	5% 1/16W
JW201	1-216-295-11	SHORT 0		R115	1-216-833-11	METAL CHIP 10K	5% 1/16W
JW202	1-216-295-11	SHORT 0		R116	1-216-839-11	METAL CHIP 33K	5% 1/16W
JW203	1-216-295-11	SHORT 0		R117	1-216-837-11	METAL CHIP 22K	5% 1/16W
JW903	1-216-295-11	SHORT 0		R118	1-218-855-11	METAL CHIP 2.2K	0.5% 1/16W
JW904	1-216-295-11	SHORT 0		R119	1-218-863-11	METAL CHIP 4.7K	0.5% 1/16W
< COIL >				R120	1-218-889-11	METAL CHIP 56K	0.5% 1/16W
L101	1-500-245-11	INDUCTOR CHIP 0uH		R121	1-218-863-11	METAL CHIP 4.7K	0.5% 1/16W
L102	1-500-245-11	INDUCTOR CHIP 0uH		R122	1-218-855-11	METAL CHIP 2.2K	0.5% 1/16W
L103	1-500-245-11	INDUCTOR CHIP 0uH		R123	1-216-819-11	METAL CHIP 680	5% 1/16W
L105	1-414-235-22	INDUCTOR CHIP 0uH		R124	1-216-809-11	METAL CHIP 100	5% 1/16W
L106	1-500-245-11	INDUCTOR CHIP 0uH		R125	1-216-815-11	METAL CHIP 330	5% 1/16W
L121	1-500-245-11	INDUCTOR CHIP 0uH		R126	1-216-819-11	METAL CHIP 680	5% 1/16W
L122	1-500-245-11	INDUCTOR CHIP 0uH		R127	1-216-845-11	METAL CHIP 100K	5% 1/16W
L131	1-500-245-11	INDUCTOR CHIP 0uH		R128	1-219-724-11	METAL CHIP 1	1% 1/4W
L141	1-412-029-11	INDUCTOR CHIP 10uH		R129	1-216-298-00	METAL CHIP 2.2	5% 1/10W
L142	1-412-032-11	INDUCTOR CHIP 100uH		R130	1-216-829-11	METAL CHIP 4.7K	5% 1/16W
L143	1-412-029-11	INDUCTOR CHIP 10uH		R131	1-216-833-11	METAL CHIP 10K	5% 1/16W
L144	1-412-032-11	INDUCTOR CHIP 100uH		R132	1-216-839-11	METAL CHIP 33K	5% 1/16W
L145	1-412-032-11	INDUCTOR CHIP 100uH		R133	1-216-821-11	METAL CHIP 1K	5% 1/16W
L146	1-469-855-21	FERRITE 0uH		R134	1-216-821-11	METAL CHIP 1K	5% 1/16W
L147	1-469-855-21	FERRITE 0uH		R135	1-216-821-11	METAL CHIP 1K	5% 1/16W
				R136	1-216-302-00	METAL CHIP 2.7	5% 1/10W
				R138	1-216-833-11	METAL CHIP 10K	5% 1/16W
				R150	1-216-833-11	METAL CHIP 10K	5% 1/16W

BD (MD)**CALMP MOTOR****CONNECTOR****DIGITAL**

Ref. No.	Part No.	Description	Remark
R151	1-216-833-11	METAL CHIP	10K 5% 1/16W
R153	1-216-833-11	METAL CHIP	10K 5% 1/16W
R155	1-216-864-11	METAL CHIP	0
R156	1-216-864-11	METAL CHIP	0
R158	1-216-809-11	METAL CHIP	100 5% 1/16W
R162	1-216-833-11	METAL CHIP	10K 5% 1/16W
R167	1-216-833-11	METAL CHIP	10K 5% 1/16W
R168	1-216-845-11	METAL CHIP	100K 5% 1/16W
R169	1-216-855-11	METAL CHIP	680K 5% 1/16W
R170	1-216-827-11	METAL CHIP	3.3K 5% 1/16W
R171	1-216-821-11	METAL CHIP	1K 5% 1/16W
R173	1-216-821-11	METAL CHIP	1K 5% 1/16W
R174	1-216-811-11	METAL CHIP	150 5% 1/16W
R177	1-216-805-11	METAL CHIP	47 5% 1/16W
R179	1-216-295-11	SHORT	0
R181	1-216-841-11	METAL CHIP	47K 5% 1/16W
R182	1-216-841-11	METAL CHIP	47K 5% 1/16W
R183	1-216-841-11	METAL CHIP	47K 5% 1/16W
R184	1-220-942-11	METAL CHIP	3.3 1% 1/4W
R185	1-220-942-11	METAL CHIP	3.3 1% 1/4W
R195	1-216-833-11	METAL CHIP	10K 5% 1/16W
R196	1-216-833-11	METAL CHIP	10K 5% 1/16W
R197	1-216-833-11	METAL CHIP	10K 5% 1/16W
R218	1-216-864-11	METAL CHIP	0
< SWITCH >			
S101	1-762-596-21	SWITCH, PUSH (1 KEY) (LIMIT IN SW)	
S103	1-771-956-21	SWITCH, PUSH (1 KEY) (OUT SW)	
S104	1-771-955-21	SWITCH, PUSH (1 KEY) (PLAY SW)	
S105	1-771-955-21	SWITCH, PUSH (1 KEY) (REC SW)	
< VIBRATOR >			
X171	1-781-569-21	OSCILLATOR, CRYSTAL (90MHz)	

	1-671-507-11	CLAMP MOTOR BOARD	

< CAPACITOR >			
C701	1-162-306-11	CERAMIC	0.01uF 30.00% 16V
C702	1-126-964-11	ELECT	10uF 20.00% 50V
C711	1-162-306-11	CERAMIC	0.01uF 30.00% 16V
< CONNECTOR >			
CN712	1-506-469-11	PIN, CONNECTOR 4P	
< DIODE >			
D701	8-719-983-66	DIODE MTZJ-T-72-3.6B	
< IC >			
IC701	8-759-633-65	IC M54641L	
< RESISTOR >			
R701	1-249-411-11	CARBON	330 5% 1/4W
R702	1-249-401-11	CARBON	47 5% 1/4W F

Ref. No.	Part No.	Description	Remark
	1-671-506-11	CONNECTOR BOARD	

< CONNECTOR >			
CN701	1-568-860-11	SOCKET, CONNECTOR 17P	
< TRANSISTOR >			
Q701	8-729-029-66	TRANSISTOR RT1N141S-TP	
< RESISTOR >			
R707	1-249-424-11	CARBON	3.9K 5% 1/4W F
R708	1-249-417-11	CARBON	1K 5% 1/4W F
R709	1-249-429-11	CARBON	10K 5% 1/4W

	A-4725-324-A	DIGITAL BOARD, COMPLETE	

< CAPACITOR >			
C1001	1-126-934-11	ELECT	220uF 20.00% 10V
C1002	1-163-038-11	CERAMIC CHIP	0.1uF 25V
C1003	1-126-933-11	ELECT	100uF 20.00% 16V
C1004	1-163-038-11	CERAMIC CHIP	0.1uF 25V
C1005	1-126-933-11	ELECT	100uF 20.00% 16V
C1006	1-163-038-11	CERAMIC CHIP	0.1uF 25V
C1007	1-126-933-11	ELECT	100uF 20.00% 16V
C1008	1-163-038-11	CERAMIC CHIP	0.1uF 25V
C1009	1-163-038-11	CERAMIC CHIP	0.1uF 25V
C1010	1-126-933-11	ELECT	100uF 20.00% 16V
C1011	1-163-038-11	CERAMIC CHIP	0.1uF 25V
C1012	1-126-933-11	ELECT	100uF 20.00% 16V
C1013	1-126-933-11	ELECT	100uF 20.00% 16V
C1014	1-163-038-11	CERAMIC CHIP	0.1uF 25V
C1015	1-126-933-11	ELECT	100uF 20.00% 16V
C1016	1-163-038-11	CERAMIC CHIP	0.1uF 25V
C1017	1-163-038-11	CERAMIC CHIP	0.1uF 25V
C1018	1-163-038-11	CERAMIC CHIP	0.1uF 25V
C1019	1-163-009-11	CERAMIC CHIP	0.001uF 10% 50V
C1020	1-163-009-11	CERAMIC CHIP	0.001uF 10% 50V
C1021	1-163-038-11	CERAMIC CHIP	0.1uF 25V
C1022	1-126-933-11	ELECT	100uF 20.00% 16V
C1023	1-163-038-11	CERAMIC CHIP	0.1uF 25V
C1024	1-163-038-11	CERAMIC CHIP	0.1uF 25V
C1025	1-163-038-11	CERAMIC CHIP	0.1uF 25V
C1026	1-126-933-11	ELECT	100uF 20.00% 16V
C1027	1-163-031-11	CERAMIC CHIP	0.01uF 50V
C1031	1-163-038-11	CERAMIC CHIP	0.1uF 25V
C1034	1-163-031-11	CERAMIC CHIP	0.01uF 50V
C1035	1-163-038-11	CERAMIC CHIP	0.1uF 25V
C1037	1-163-117-00	CERAMIC CHIP	100PF 5% 50V
C1038	1-163-117-00	CERAMIC CHIP	100PF 5% 50V
C1039	1-163-117-00	CERAMIC CHIP	100PF 5% 50V
C1040	1-163-117-00	CERAMIC CHIP	100PF 5% 50V
C1041	1-163-117-00	CERAMIC CHIP	100PF 5% 50V
C1044	1-163-009-11	CERAMIC CHIP	0.001uF 10% 50V
C1045	1-126-933-11	ELECT	100uF 20.00% 16V
C1046	1-136-153-00	FILM	0.01uF 5% 50V
C1047	1-136-153-00	FILM	0.01uF 5% 50V

DIGITAL**IN SW****INT/COUNT SW****LOAD MOTOR**

Ref. No.	Part No.	Description		Remark	Ref. No.	Part No.	Description		Remark
C1048	1-126-933-11	ELECT	100uF	20.00% 16V	R1051	1-216-073-00	METAL CHIP	10K	5% 1/10W
		< CONNECTOR >			R1052	1-216-073-00	METAL CHIP	10K	5% 1/10W
CN1001	1-784-747-11	CONNECTOR, FFC 25P			R1053	1-216-073-00	METAL CHIP	10K	5% 1/10W
CN1003	1-779-295-11	CONNECTOR, FFC (LIF (NON-ZIF)) 27P			R1054	1-216-073-00	METAL CHIP	10K	5% 1/10W
CN1004	1-779-285-11	CONNECTOR, FFC (LIF (NON-ZIF)) 17P			R1055	1-216-073-00	METAL CHIP	10K	5% 1/10W
		< IC >			R1056	1-216-073-00	METAL CHIP	10K	5% 1/10W
IC1001	8-759-677-81	IC M30805SGP			R1057	1-216-065-91	RES-CHIP	4.7K	5% 1/10W
IC1002	8-759-685-90	IC MT28F800B3WG-10T-SYS70			R1058	1-216-041-00	METAL CHIP	470	5% 1/10W
IC1004	8-759-822-09	IC LB1641			R1059	1-216-041-00	METAL CHIP	470	5% 1/10W
IC1005	8-759-675-78	IC UDA1360TS			R1060	1-216-041-00	METAL CHIP	470	5% 1/10W
IC1006	8-759-675-77	IC UDA1350AH			R1071	1-216-073-00	METAL CHIP	10K	5% 1/10W
		< COIL >			R1072	1-216-073-00	METAL CHIP	10K	5% 1/10W
L1001	1-412-533-21	INDUCTOR 47uH			R1073	1-216-073-00	METAL CHIP	10K	5% 1/10W
		< TRANSISTOR >			R1075	1-216-025-11	RES-CHIP	100	5% 1/10W
Q1001	8-729-421-19	TRANSISTOR UN2213-TW			R1076	1-216-073-00	METAL CHIP	10K	5% 1/10W
Q1002	8-729-602-36	TRANSISTOR 2SA1602TP-1EF			R1077	1-216-295-11	SHORT	0	
Q1003	8-729-602-36	TRANSISTOR 2SA1602TP-1EF			R1078	1-216-295-11	SHORT	0	
Q1004	8-729-424-18	TRANSISTOR UN2113-TX			R1079	1-216-295-11	SHORT	0	
		< RESISTOR >			R1080	1-216-295-11	SHORT	0	
R1001	1-216-066-00	METAL CHIP	5.1K	5% 1/10W	R1081	1-216-073-00	METAL CHIP	10K	5% 1/10W
R1002	1-216-066-00	METAL CHIP	5.1K	5% 1/10W	R1082	1-216-073-00	METAL CHIP	10K	5% 1/10W
R1005	1-216-025-11	RES-CHIP	100	5% 1/10W	R1083	1-216-073-00	METAL CHIP	10K	5% 1/10W
R1006	1-216-025-11	RES-CHIP	100	5% 1/10W	R1084	1-216-073-00	METAL CHIP	10K	5% 1/10W
R1007	1-216-041-00	METAL CHIP	470	5% 1/10W	R1088	1-216-069-00	METAL CHIP	6.8K	5% 1/10W
					R1090	1-216-041-00	METAL CHIP	470	5% 1/10W
R1010	1-216-025-11	RES-CHIP	100	5% 1/10W	R1091	1-216-033-00	METAL CHIP	220	5% 1/10W
R1011	1-216-073-00	METAL CHIP	10K	5% 1/10W	R1092	1-216-033-00	METAL CHIP	220	5% 1/10W
R1012	1-216-073-00	METAL CHIP	10K	5% 1/10W	R1093	1-216-033-00	METAL CHIP	220	5% 1/10W
R1013	1-216-073-00	METAL CHIP	10K	5% 1/10W	R1094	1-216-033-00	METAL CHIP	220	5% 1/10W
R1014	1-216-073-00	METAL CHIP	10K	5% 1/10W	R1095	1-216-039-00	METAL CHIP	390	5% 1/10W
					R2002	1-216-296-91	SHORT	0	
R1015	1-216-073-00	METAL CHIP	10K	5% 1/10W			< VIBRATOR >		
R1016	1-216-073-00	METAL CHIP	10K	5% 1/10W	X1001	1-579-175-11	VIBRATOR, CERAMIC (10MHz)		
R1017	1-216-073-00	METAL CHIP	10K	5% 1/10W	*****				
R1018	1-216-073-00	METAL CHIP	10K	5% 1/10W	-671-505-11	IN SW BOARD			
R1024	1-216-041-00	METAL CHIP	470	5% 1/10W	*****				
						< CONNECTOR >			
R1029	1-216-049-11	METAL CHIP	1K	5% 1/10W	* CN710	1-568-941-11	PIN, CONNECTOR 3P		
R1030	1-216-061-00	METAL CHIP	3.3K	5% 1/10W			< SWITCH >		
R1033	1-216-055-00	METAL CHIP	1.8K	5% 1/10W	S703	1-771-218-11	SWITCH, MICRO(MID IN)		
R1034	1-216-057-00	METAL CHIP	2.2K	5% 1/10W	S704	1-771-218-11	SWITCH, MICRO(IN)		
R1035	1-216-073-00	METAL CHIP	10K	5% 1/10W	*****				
R1036	1-216-295-11	SHORT	0		1-671-502-11	INT/COUNT SW BOARD			
R1038	1-216-073-00	METAL CHIP	10K	5% 1/10W	*****				
R1039	1-216-073-00	METAL CHIP	10K	5% 1/10W	S705	1-771-264-11	SWITCH, PUSH (DETECTION)(1 KEY)(INT)		
R1040	1-216-073-00	METAL CHIP	10K	5% 1/10W	S706	1-771-264-11	SWITCH, PUSH (DETECTION)(1 KEY)(COUNT)		
R1041	1-216-073-00	METAL CHIP	10K	5% 1/10W	*****				
					1-671-508-1	LOAD MOTOR BOARD			
R1042	1-216-073-00	METAL CHIP	10K	5% 1/10W	*****				
R1043	1-216-073-00	METAL CHIP	10K	5% 1/10W			< CAPACITOR >		
R1044	1-216-073-00	METAL CHIP	10K	5% 1/10W	C703	1-162-306-11	CERAMIC	0.01uF	30.00% 16V
R1045	1-216-073-00	METAL CHIP	10K	5% 1/10W					
R1046	1-216-073-00	METAL CHIP	10K	5% 1/10W					
R1047	1-216-073-00	METAL CHIP	10K	5% 1/10W					
R1048	1-216-073-00	METAL CHIP	10K	5% 1/10W					
R1049	1-216-073-00	METAL CHIP	10K	5% 1/10W					
R1050	1-216-073-00	METAL CHIP	10K	5% 1/10W					

Ref. No.	Part No.	Description		Remark	Ref. No.	Part No.	Description		Remark	
C704	1-126-964-11	ELECT	10uF	20.00%	50V	C719	1-162-294-31	CERAMIC	0.001uF 10%	50V
C712	1-162-306-11	CERAMIC	0.01uF	30.00%	16V	C720	1-162-294-31	CERAMIC	0.001uF 10%	50V
		< CONNECTOR >				C722	1-162-294-31	CERAMIC	0.001uF 10%	50V
CN713	1-506-469-11	PIN, CONNECTOR 4P				C723	1-162-294-31	CERAMIC	0.001uF 10%	50V
		< DIODE >				C724	1-162-294-31	CERAMIC	0.001uF 10%	50V
D702	8-719-109-85	DIODE MTZJ-T-72-5.1B				C725	1-162-294-31	CERAMIC	0.001uF 10%	50V
		< IC >				C802	1-164-159-11	CERAMIC	0.1uF	50V
IC702	8-759-633-65	IC M54641L				C803	1-164-159-11	CERAMIC	0.1uF	50V
		< RESISTOR >				C812	1-164-159-11	CERAMIC	0.1uF	50V
R703	1-249-411-11	CARBON	330	5%	1/4W	C813	1-164-159-11	CERAMIC	0.1uF	50V
R704	1-249-401-11	CARBON	47	5%	1/4W F	C814	1-162-282-31	CERAMIC	100PF 10%	50V

	A-4725-321-A	MAIN BOARD, COMPLETE (AEP,UK,G,AED,CIS)				C815	1-164-159-11	CERAMIC	0.1uF	50V
		*****				C816	1-162-282-31	CERAMIC	100PF 10%	50V
	A-4725-326-A	MAIN BOARD, COMPLETE (MY,SP)				C817	1-164-159-11	CERAMIC	0.1uF	50V
		*****				C818	1-164-159-11	CERAMIC	0.1uF	50V
	3-349-019-32	HEAT SINK				C903	1-126-946-11	ELECT	6800uF 20.00%	25V
	7-685-646-79	SCREW +BVTP 3X8 TYPE2 SLIT				C904	1-126-946-11	ELECT	6800uF 20.00%	25V
		< CAPACITOR >				C906	1-126-768-11	ELECT	2200uF 20.00%	16V
C101	1-164-159-11	CERAMIC	0.1uF		50V	C907	1-126-964-11	ELECT	100uF 20.00%	50V
C104	1-104-656-11	ELECT	2200uF	20.00%	6.3V	C908	1-126-926-11	ELECT	1000uF 20.00%	10V
C151	1-164-159-11	CERAMIC	0.1uF		50V	C909	1-126-964-11	ELECT	10uF 20.00%	50V
C152	1-164-159-11	CERAMIC	0.1uF		50V	C910	1-126-925-11	ELECT	470uF 20.00%	10V
C171	1-126-961-11	ELECT	2.2uF	20.00%	50V	C912	1-126-964-11	ELECT	10uF 20.00%	50V
C172	1-126-961-11	ELECT	2.2uF	20.00%	50V	C913	1-126-926-11	ELECT	1000uF 20.00%	10V
C173	1-126-964-11	ELECT	10uF	20.00%	50V	C914	1-164-159-11	CERAMIC	0.1uF	50V
C174	1-126-964-11	ELECT	10uF	20.00%	50V	C915	1-126-925-11	ELECT	470uF 20.00%	10V
C180	1-164-159-11	CERAMIC	0.1uF		50V	C921	1-164-159-11	CERAMIC	0.1uF	50V
C181	1-164-159-11	CERAMIC	0.1uF		50V	C931	1-164-159-11	CERAMIC	0.1uF	50V
C182	1-164-159-11	CERAMIC	0.1uF		50V	C932	1-126-960-11	ELECT	1uF 20.00%	50V
C183	1-164-159-11	CERAMIC	0.1uF		50V	C933	1-164-159-11	CERAMIC	0.1uF	50V
C184	1-164-159-11	CERAMIC	0.1uF		50V	C934	1-104-905-11	CAPACITOR	0.22F	5.5V
C185	1-164-159-11	CERAMIC	0.1uF		50V	C951	1-126-964-11	ELECT	10uF 20.00%	50V
C190	1-164-159-11	CERAMIC	0.1uF		50V	C952	1-164-159-11	CERAMIC	0.1uF	50V
C192	1-164-159-11	CERAMIC	0.1uF		50V			< CONNECTOR >		
C193	1-126-964-11	ELECT	10uF	20.00%	50V	CN101	1-793-351-41	SOCKET, CONNECTOR 19P		
C194	1-162-290-31	CERAMIC	470PF	10%	50V	CN102	1-568-828-11	CONNECTOR, FFC 9P		
C195	1-162-290-31	CERAMIC	470PF	10%	50V	CN103	1-784-774-11	CONNECTOR, FFC 13P		
C196	1-164-159-11	CERAMIC	0.1uF		50V	CN111	1-784-780-11	CONNECTOR, FFC 19P		
C199	1-164-159-11	CERAMIC	0.1uF		50V	CN112	1-784-778-11	CONNECTOR, FFC 17P		
C701	1-164-159-11	CERAMIC	0.1uF		50V	CN114	1-784-786-11	CONNECTOR, FFC 25P		
C703	1-164-159-11	CERAMIC	0.1uF		50V			< DIODE >		
C704	1-164-159-11	CERAMIC	0.1uF		50V	D170	1-162-294-11	CERAMIC	1000pF	
C707	1-164-159-11	CERAMIC	0.1uF		50V	D190	8-719-024-99	DIODE 11ES2-NTA2B		
C709	1-164-159-11	CERAMIC	0.1uF		50V	D191	8-719-024-99	DIODE 11ES2-NTA2B		
C710	1-164-159-11	CERAMIC	0.1uF		50V	D193	8-719-911-19	DIODE 1SS133T-72		
C713	1-162-294-31	CERAMIC	0.001uF	10%	50V	D194	8-719-911-19	DIODE 1SS133T-72		
C714	1-162-294-31	CERAMIC	0.001uF	10%	50V	D195	8-719-911-19	DIODE 1SS133T-72		
C716	1-162-294-31	CERAMIC	0.001uF	10%	50V	D814	8-719-911-19	DIODE 1SS133T-72		
C718	1-162-294-31	CERAMIC	0.001uF	10%	50V	D816	8-719-911-19	DIODE 1SS133T-72		
						D901	8-719-200-02	DIODE 10E-2FD		
						D902	8-719-200-02	DIODE 10E-2FD		
						D903	8-719-200-02	DIODE 10E-2FD		
						D904	8-719-200-02	DIODE 10E-2FD		
						D905	8-719-200-02	DIODE 10E-2FD		
						D906	8-719-200-02	DIODE 10E-2FD		
						D907	8-719-024-99	DIODE 11ES2-NTA2B		

MAIN

Ref. No.	Part No.	Description				Remark	Ref. No.	Part No.	Description				Remark
D908	8-719-024-99	DIODE 11ES2-NTA2B					R129	1-247-807-31	CARBON	100	5%	1/4W	
D909	8-719-024-99	DIODE 11ES2-NTA2B					R130	1-249-429-11	CARBON	10K	5%	1/4W	
D910	8-719-024-99	DIODE 11ES2-NTA2B					R131	1-249-417-11	CARBON	1K	5%	1/4W	F
D911	8-719-911-19	DIODE 1SS133T-72					R132	1-249-417-11	CARBON	1K	5%	1/4W	F
D912	8-719-911-19	DIODE 1SS133T-72					R133	1-249-417-11	CARBON	1K	5%	1/4W	F
D913	8-719-911-19	DIODE 1SS133T-72					R134	1-249-417-11	CARBON	1K	5%	1/4W	F
D951	8-719-911-19	DIODE 1SS133T-72					R135	1-249-417-11	CARBON	1K	5%	1/4W	F
D952	8-719-911-19	DIODE 1SS133T-72					R142	1-249-417-11	CARBON	1K	5%	1/4W	F
		< FERRITE BEAD >					R143	1-249-417-11	CARBON	1K	5%	1/4W	F
							R144	1-249-417-11	CARBON	1K	5%	1/4W	F
FB101	1-412-473-21	INDUCTOR	0UH				R145	1-249-429-11	CARBON	10K	5%	1/4W	
FB189	1-412-473-21	INDUCTOR	0UH				R146	1-249-429-11	CARBON	10K	5%	1/4W	
		< IC >					R147	1-249-429-11	CARBON	10K	5%	1/4W	
							R148	1-247-807-31	CARBON	100	5%	1/4W	
IC101	8-759-668-65	IC M30620MCA-A41FP					R149	1-247-807-31	CARBON	100	5%	1/4W	
IC901	8-759-604-32	IC M5F7810L					R150	1-247-807-31	CARBON	100	5%	1/4W	
IC902	8-759-231-53	IC M5F7805L					R151	1-247-807-31	CARBON	100	5%	1/4W	
IC903	8-759-231-53	IC M5F7805L					R152	1-247-807-31	CARBON	100	5%	1/4W	
IC904	8-759-686-72	IC uPD29L04J-T					R153	1-247-807-31	CARBON	100	5%	1/4W	
IC905	8-759-604-86	IC M5F7807L					R154	1-247-807-31	CARBON	100	5%	1/4W	
IC931	8-759-481-02	IC M62016L					R155	1-247-807-31	CARBON	100	5%	1/4W	
IC951	8-759-635-63	IC M51943BSL-TP					R156	1-247-807-31	CARBON	100	5%	1/4W	
		< TRANSISTOR >					R157	1-247-807-31	CARBON	100	5%	1/4W	
							R158	1-247-807-31	CARBON	100	5%	1/4W	
Q191	8-729-040-20	TRANSISTOR RT1P137L-TP					R159	1-247-807-31	CARBON	100	5%	1/4W	
Q192	8-729-900-80	TRANSISTOR BA1A4M-TP					R160	1-247-807-31	CARBON	100	5%	1/4W	
Q921	8-729-040-20	TRANSISTOR RT1P137L-TP					R161	1-247-807-31	CARBON	100	5%	1/4W	
Q922	8-729-900-80	TRANSISTOR BA1A4M-TP					R162	1-247-807-31	CARBON	100	5%	1/4W	
		< RESISTOR >					R163	1-247-807-31	CARBON	100	5%	1/4W	
							R164	1-247-807-31	CARBON	100	5%	1/4W	
R101	1-249-413-11	CARBON	470	5%	1/4W	F	R167	1-249-429-11	CARBON	10K	5%	1/4W	
R102	1-249-417-11	CARBON	1K	5%	1/4W	F	R168	1-249-429-11	CARBON	10K	5%	1/4W	
R103	1-249-417-11	CARBON	1K	5%	1/4W	F	R169	1-247-807-31	CARBON	100	5%	1/4W	
R104	1-249-417-11	CARBON	1K	5%	1/4W	F	R171	1-249-435-11	CARBON	33K	5%	1/4W	
R105	1-247-807-31	CARBON	100	5%	1/4W		R172	1-249-435-11	CARBON	33K	5%	1/4W	
R106	1-247-807-31	CARBON	100	5%	1/4W		R175	1-249-429-11	CARBON	10K	5%	1/4W	
R107	1-249-429-11	CARBON	10K	5%	1/4W		R176	1-249-429-11	CARBON	10K	5%	1/4W	
R108	1-247-807-31	CARBON	100	5%	1/4W		R177	1-249-429-11	CARBON	10K	5%	1/4W	
R109	1-247-807-31	CARBON	100	5%	1/4W		R178	1-249-429-11	CARBON	10K	5%	1/4W	
R110	1-249-417-11	CARBON	1K	5%	1/4W	F	R179	1-249-429-11	CARBON	10K	5%	1/4W	
R111	1-249-411-11	CARBON	330	5%	1/4W		R180	1-249-429-11	CARBON	10K	5%	1/4W	
R112	1-249-429-11	CARBON	10K	5%	1/4W		R181	1-249-429-11	CARBON	10K	5%	1/4W	
R113	1-247-807-31	CARBON	100	5%	1/4W		R182	1-249-429-11	CARBON	10K	5%	1/4W	
R114	1-247-807-31	CARBON	100	5%	1/4W		R183	1-249-429-11	CARBON	10K	5%	1/4W	
R115	1-247-807-31	CARBON	100	5%	1/4W		R184	1-249-429-11	CARBON	10K	5%	1/4W	
R116	1-247-807-31	CARBON	100	5%	1/4W		R185	1-249-429-11	CARBON	10K	5%	1/4W	
R117	1-249-409-11	CARBON	220	5%	1/4W	F	R189	1-247-807-31	CARBON	100	5%	1/4W	
R118	1-249-409-11	CARBON	220	5%	1/4W	F	R191	1-249-417-11	CARBON	1K	5%	1/4W	F
R119	1-249-429-11	CARBON	10K	5%	1/4W		R192	1-249-421-11	CARBON	2.2K	5%	1/4W	F
R120	1-249-429-11	CARBON	10K	5%	1/4W		R193	1-249-417-11	CARBON	1K	5%	1/4W	F
R121	1-249-429-11	CARBON	10K	5%	1/4W		R198	1-249-429-11	CARBON	10K	5%	1/4W	
R122	1-249-429-11	CARBON	10K	5%	1/4W		R199	1-249-429-11	CARBON	10K	5%	1/4W	
R123	1-249-417-11	CARBON	1K	5%	1/4W	F	R931	1-249-429-11	CARBON	10K	5%	1/4W	
R124	1-249-417-11	CARBON	1K	5%	1/4W	F	R951	1-249-417-11	CARBON	1K	5%	1/4W	F
R125	1-249-417-11	CARBON	1K	5%	1/4W	F	R952	1-249-429-11	CARBON	10K	5%	1/4W	
R126	1-249-417-11	CARBON	1K	5%	1/4W	F	R953	1-249-433-11	CARBON	22K	5%	1/4W	
R127	1-249-417-11	CARBON	1K	5%	1/4W	F	R954	1-249-419-11	CARBON	1.5K	5%	1/4W	F
R128	1-249-429-11	CARBON	10K	5%	1/4W		R955	1-249-409-11	CARBON	220	5%	1/4W	F

Ref. No.	Part No.	Description	Remark	Ref. No.	Part No.	Description	Remark
R967	1-247-871-11	CARBON 47K 5%	1/4W			< EARTH TERMINAL >	
		< VIBRATOR >		* EPT201	1-537-738-21	TERMINAL, EARTH	
X101	1-781-107-21	VIBRATOR, SERAMIC(16MHz)		* EPT202	1-537-738-21	TERMINAL, EARTH	
*****						< TRANSISTOR >	
	1-671-503-11	OUT SW BOARD		Q205	8-729-900-80	TRANSISTOR BA1A4M-TP	
		*****		Q209	8-729-900-80	TRANSISTOR BA1A4M-TP	
		< CONNECTOR >		Q210	8-729-900-80	TRANSISTOR BA1A4M-TP	
* CN709	1-568-943-11	PIN, CONNECTOR 5P		Q211	8-729-900-80	TRANSISTOR BA1A4M-TP	
CN715	1-506-481-11	PIN, CONNECTOR 2P		Q212	8-729-900-80	TRANSISTOR BA1A4M-TP	
		< SWITCH >		Q213	8-729-900-80	TRANSISTOR BA1A4M-TP	
S701	1-771-218-11	SWITCH, MICRO (MID OUT)				< RESISTOR >	
S702	1-771-218-11	SWITCH, MICRO (LID)		R201	1-249-410-11	CARBON 270 5%	1/4W F
S708	1-771-218-11	SWITCH, MICRO (OUT)		R202	1-249-411-11	CARBON 330 5%	1/4W
*****				R203	1-249-413-11	CARBON 470 5%	1/4W F
	A-4725-318-A	PANEL BOARD, COMPLETE		R204	1-249-414-11	CARBON 560 5%	1/4W F
		*****		R205	1-249-415-11	CARBON 680 5%	1/4W F
		< CAPACITOR >		R206	1-249-417-11	CARBON 1K 5%	1/4W F
C201	1-162-306-11	CERAMIC 0.01uF 30.00%	16V	R207	1-249-418-11	CARBON 1.2K 5%	1/4W F
C202	1-162-306-11	CERAMIC 0.01uF 30.00%	16V	R208	1-249-420-11	CARBON 1.8K 5%	1/4W F
C203	1-164-159-11	CERAMIC 0.1uF	50V	R209	1-249-422-11	CARBON 2.7K 5%	1/4W F
C204	1-164-159-11	CERAMIC 0.1uF	50V	R211	1-249-407-11	CARBON 150 5%	1/4W F
C205	1-164-159-11	CERAMIC 0.1uF	50V	R216	1-249-410-11	CARBON 270 5%	1/4W F
C206	1-164-159-11	CERAMIC 0.1uF	50V	R217	1-249-411-11	CARBON 330 5%	1/4W
C207	1-164-159-11	CERAMIC 0.1uF	50V	R218	1-249-413-11	CARBON 470 5%	1/4W F
C208	1-164-159-11	CERAMIC 0.1uF	50V	R219	1-249-414-11	CARBON 560 5%	1/4W F
C209	1-164-159-11	CERAMIC 0.1uF	50V	R220	1-249-415-11	CARBON 680 5%	1/4W F
C210	1-164-159-11	CERAMIC 0.1uF	50V	R221	1-249-417-11	CARBON 1K 5%	1/4W F
C211	1-164-159-11	CERAMIC 0.1uF	50V	R222	1-249-418-11	CARBON 1.2K 5%	1/4W F
		< CONNECTOR >		R223	1-249-420-11	CARBON 1.8K 5%	1/4W F
CN201	1-784-774-11	CONNECTOR, FFC 13P		R224	1-249-422-11	CARBON 2.7K 5%	1/4W F
		< DIODE >		R225	1-247-843-11	CARBON 3.3K 5%	1/4W
D201	8-719-076-15	DIODE SELS6B14C-TP6 (KEY ILLUMINATION)		R226	1-249-425-11	CARBON 4.7K 5%	1/4W F
D202	8-719-076-15	DIODE SELS6B14C-TP6 (KEY ILLUMINATION)		R227	1-249-427-11	CARBON 6.8K 5%	1/4W F
D203	8-719-076-15	DIODE SELS6B14C-TP6 (KEY ILLUMINATION)		R228	1-249-429-11	CARBON 10K 5%	1/4W
D204	8-719-076-15	DIODE SELS6B14C-TP6 (KEY ILLUMINATION)		R231	1-249-442-11	CARBON 510 5%	1/4W
D206	8-719-081-80	DIODE SEL5823A-D2D3-TP15 (DISC (CD) 1)		R232	1-249-442-11	CARBON 510 5%	1/4W
D207	8-719-081-80	DIODE SEL5823A-D2D3-TP15 (DISC (CD) 2)		R235	1-247-807-31	CARBON 100 5%	1/4W
D208	8-719-081-80	DIODE SEL5823A-D2D3-TP15 (DISC (CD) 3)		R236	1-247-807-31	CARBON 100 5%	1/4W
D209	8-719-081-80	DIODE SEL5823A-D2D3-TP15 (DISC (CD) 4)		R237	1-249-442-11	CARBON 510 5%	1/4W
D210	8-719-081-80	DIODE SEL5823A-D2D3-TP15 (DISC (CD) 5)		R238	1-249-442-11	CARBON 510 5%	1/4W
D218	8-719-076-15	DIODE SELS6B14C-TP6 (KEY ILLUMINATION)		R239	1-249-442-11	CARBON 510 5%	1/4W
D219	8-719-076-15	DIODE SELS6B14C-TP6 (KEY ILLUMINATION)		R240	1-247-807-31	CARBON 100 5%	1/4W
D220	8-719-076-15	DIODE SELS6B14C-TP6 (KEY ILLUMINATION)		R241	1-247-843-11	CARBON 3.3K 5%	1/4W
D221	8-719-076-15	DIODE SELS6B14C-TP6 (KEY ILLUMINATION)		R248	1-249-407-11	CARBON 150 5%	1/4W F
D222	8-719-076-15	DIODE SELS6B14C-TP6 (KEY ILLUMINATION)		R251	1-249-407-11	CARBON 150 5%	1/4W F
D223	8-719-076-15	DIODE SELS6B14C-TP6 (KEY ILLUMINATION)		R258	1-247-807-31	CARBON 100 5%	1/4W
D224	8-719-076-15	DIODE SELS6B14C-TP6 (KEY ILLUMINATION)		R259	1-247-807-31	CARBON 100 5%	1/4W
D225	8-719-076-15	DIODE SELS6B14C-TP6 (KEY ILLUMINATION)		R262	1-247-807-31	CARBON 100 5%	1/4W
		< SWITCH >		S201	1-762-875-21	SWITCH, KEYBOARD (▷ (MD))	
				S202	1-762-875-21	SWITCH, KEYBOARD (◻ (MD))	
				S203	1-762-875-21	SWITCH, KEYBOARD (◻ (MD))	
				S204	1-762-875-21	SWITCH, KEYBOARD (△ (MD))	
				S205	1-762-875-21	SWITCH, KEYBOARD (▶▶ (MD))	

HMC-NX5MD

PANEL	REC	SENSOR	SENSOR 2
-------	-----	--------	----------

Ref. No.	Part No.	Description	Remark
S206	1-762-875-21	SWITCH, KEYBOARD (◀ (MD))	
S207	1-762-875-21	SWITCH, KEYBOARD (NAME EDIT/CHARACTER)	
S208	1-762-875-21	SWITCH, KEYBOARD (CLEAR)	
S209	1-762-875-21	SWITCH, KEYBOARD (ENTER/YES)	
S210	1-762-875-21	SWITCH, KEYBOARD (MENU/NO)	
S211	1-762-875-21	SWITCH, KEYBOARD (▷ (CD))	
S212	1-762-875-21	SWITCH, KEYBOARD (⏏ (CD))	
S213	1-762-875-21	SWITCH, KEYBOARD (□ (CD))	
S214	1-762-875-21	SWITCH, KEYBOARD (DISC (CD) 1)	
S215	1-762-875-21	SWITCH, KEYBOARD (DISC (CD) 2)	
S216	1-762-875-21	SWITCH, KEYBOARD (DISC (CD) 3)	
S217	1-762-875-21	SWITCH, KEYBOARD (DISC (CD) 4)	
S218	1-762-875-21	SWITCH, KEYBOARD (DISC (CD) 5)	
S219	1-762-875-21	SWITCH, KEYBOARD (⏏ (CD) 5)	
S220	1-762-875-21	SWITCH, KEYBOARD (⏏ (CD) 4)	
S221	1-762-875-21	SWITCH, KEYBOARD (⏏ (CD) 3)	
S222	1-762-875-21	SWITCH, KEYBOARD (⏏ (CD) 2)	
S223	1-762-875-21	SWITCH, KEYBOARD (⏏ (CD) 1)	
S225	1-476-134-11	ENCODER, ROTARY (◀ MD JOG ▶ +/-)	

	1-678-225-11	REC BOARD *****	
		< RESISTOR >	
R242	1-249-425-11	CARBON 4.7K 5% 1/4W F	
R243	1-249-427-11	CARBON 6.8K 5% 1/4W F	
R244	1-249-429-11	CARBON 10K 5% 1/4W	
R245	1-249-431-11	CARBON 15K 5% 1/4W	
R246	1-249-434-11	CARBON 27K 5% 1/4W	
R247	1-249-438-11	CARBON 56K 5% 1/4W	
		< SWITCH >	
S230	1-762-875-21	SWITCH, KEYBOARD (MD DISPLAY)	
S231	1-762-875-21	SWITCH, KEYBOARD (REC/REC IT)	
S232	1-762-875-21	SWITCH, KEYBOARD (NORMAL)	
S233	1-762-875-21	SWITCH, KEYBOARD (HIGH SPEED)	
S234	1-762-875-21	SWITCH, KEYBOARD (REC MODE)	
S235	1-762-875-21	SWITCH, KEYBOARD (S.F EDIT)	

	1-671-504-11	SENSOR BOARD *****	
		< CONNECTOR >	
CN708	1-506-481-11	PIN, CONNECTOR 2P	
		< DIODE >	
D704	8-719-055-84	DIODE GL528VS1 (DISC IN DETECT SENSOR)	
		< RESISTOR >	
R711	1-249-415-11	CARBON 680 5% 1/4W F	

Ref. No.	Part No.	Description	Remark
	1-671-789-11	SENSOR 2 BOARD *****	
	4-964-461-02	HOLDER (SENSOR) < TRANSISTOR >	
Q703	8-729-926-31	PHOTO TRAN ISTOP PT483F1	

		MISCELLANEOUS *****	
1	1-773-044-11	WIRE (FLAT TYPE) (17 CORE)	
2	1-791-433-11	WIRE (FLAT TYPE) (19 CORE)	
5	1-791-075-21	CORD, CONNECTION	
15	1-775-151-11	WIRE (FLAT TYPE) (17 CORE)	
16	1-775-236-11	WIRE (FLAT TYPE) (27 CORE)	
19	1-773-233-11	WIRE (FLAT TYPE) (25 CORE)	
	1-568-441-11	SOCKET, CONNECTOR 9P	
59	1-769-989-11	WIRE (FLAT TYPE) (13 CORE)	
65	1-769-916-11	WIRE (FLAT TYPE) (9 CORE)	
69	1-804-012-11	DISPLAY PANEL, LIQUID CRYSTAL	
176	1-471-061-11	MAGNET ASSY	
△251	8-820-122-01	OPTICAL PICK-UP KSM-213DHAP/Z-NP	
252	1-769-069-11	WIRE (FLAT TYPE) (16 CORE)	
457	1-678-514-11	FLEXIBLE BOARD	
△458	A-4672-541-A	OPTICAL PICK-UP KMS-260B/J1N	
HR901	1-500-670-11	HEAD, OVER LIGHT	
M101	A-4672-898-A	MOTOR ASSY, SPINDLE	
M102	A-4672-900-A	MOTOR ASSY, SLED	
M103	A-4672-975-A	MOTOR ASSY, LOADING	
M701	X-4950-341-1	MOTOR (CLAMP) ASSY	
M702	X-4950-342-1	MOTOR (LOADING) ASSY	
S102	1-771-957-11	SWITCH, PUSH (2 KEY)	
S707	1-418-045-11	ENCODER, ROTARY (DISC TRAY ADDRESS DET)	

		***** HARDWARE LIST *****	
#1	7-685-647-79	SCREW +BVTP 3X10 TYPE2 N-S	
#2	7-685-646-79	SCREW +BVTP 3X8 TYPE2 SLIT	
#3	7-685-204-19	SCREW +KTP 2X6 TYPE2 NON-SLIT	
#4	7-685-850-04	SCREW +BVTT 2X3 (S)	

The components identified by mark △ or dotted line with mark △ are critical for safety. Replace only with part number specified.