

MDS-JE480

SERVICE MANUAL



Ver. 1.4 2006.02

US Model
AEP Model
UK Model



US and foreign patents licensed form Dolby Laboratories Licensing Corporation.

Model Name Using Similar Mechanism	MDS-JE470
MD Mechanism Type	MDM-7S1A
Optical Pick-up Type	KMS-260B/260E

SPECIFICATIONS

System MiniDisc digital audio system
 Disc MiniDisc
 Laser Semiconductor laser
 ($\lambda = 780 \text{ nm}$) Emission duration: continuous
 Laser output MAX 44.6 $\mu\text{W}^{(1)}$
 1) This output is the value measured at a distance of 200mm from the objective lens surface on the Optical Pick-up Block with 7 mm aperture.
 Laser diode Material: GaAlAs
 Revolutions (CLV) 400 rpm to 900 rpm
 Error correction ACIRC (Advanced Cross Interleave Reed Solomon Code)
 Sampling frequency 44.1 kHz
 Coding ATRAC (Adaptive Transform Acoustic Coding)/ATRAC 3
 Modulation system EFM (Eight-to-Fourteen Modulation)
 Number of channels 2 stereo channels
 Frequency response 5 to 20,000 Hz $\pm 0.5 \text{ dB}$ during play
 Signal-to-noise ratio Over 96 dB during play
 Wow and flutter Below measurable limit

Inputs

ANALOG IN

Jack type: phono
Impedance: 47 kilohms
Rated input: 500 mVrms
Minimum input: 125 mVrms

DIGITAL OPTICAL IN

Connector type: square optical
Impedance: 660 nm (optical wave length)

Outputs

ANALOG OUT

Jack type: phono
Rated output: 2 Vrms (at 50 kilohms)
Load impedance: over 10 kilohms

General

Power requirements

US model:
European model:
Power consumption
Dimensions (approx.)

120 V AC, 60Hz
230 V AC, 50/60Hz
14 W (0.5 W in standby mode)
430 x 95 x 285 mm (w/h/d) incl. projecting parts and controls
3.0 kg

Mass (approx.)

Supplied accessories

Audio connecting cords (2)
Optical cable (1)
Remote commander (remote) (1)
R6 (size-AA) batteries (2)

Design and specifications are subject to change without notice.

MINIDISC DECK

9-873-964-05
2006B02-1
© 2006.02

Sony Corporation
Home Audio Division
Published by Sony Techno Create Corporation

SONY®

SAFETY CHECK-OUT

After correcting the original service problem, perform the following safety checks before releasing the set to the customer: Check the antenna terminals, metal trim, "metallized" knobs, screws, and all other exposed metal parts for AC leakage. Check leakage as described below.

LEAKAGE

The AC leakage from any exposed metal part to earth ground and from all exposed metal parts to any exposed metal part having a return to chassis, must not exceed 0.5 mA (500 microamperes). Leakage current can be measured by any one of three methods.

1. A commercial leakage tester, such as the Simpson 229 or RCA WT-540A. Follow the manufacturers' instructions to use these instruments.
2. A battery-operated AC milliammeter. The Data Precision 245 digital multimeter is suitable for this job.
3. Measuring the voltage drop across a resistor by means of a VOM or battery-operated AC voltmeter. The "limit" indication is 0.75 V, so analog meters must have an accurate low-voltage scale. The Simpson 250 and Sanwa SH-63Trd are examples of a passive VOM that is suitable. Nearly all battery operated digital multimeters that have a 2V AC range are suitable. (See Fig. A)

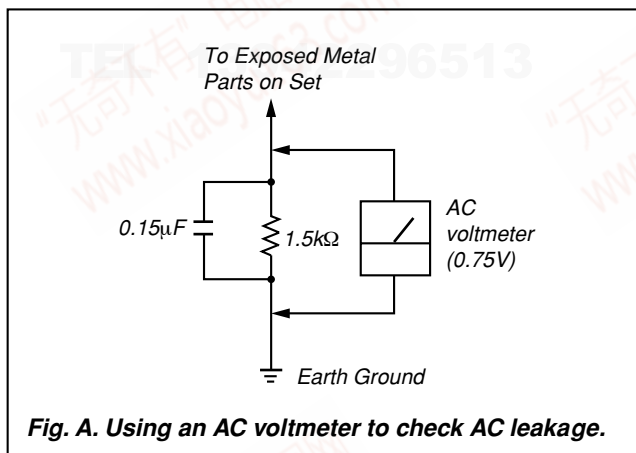

NOTES ON HANDLING THE OPTICAL PICK-UP BLOCK OR BASE UNIT

The laser diode in the optical pick-up block may suffer electrostatic break-down because of the potential difference generated by the charged electrostatic load, etc. on clothing and the human body. During repair, pay attention to electrostatic break-down and also use the procedure in the printed matter which is included in the repair parts. The flexible board is easily damaged and should be handled with care.

NOTES ON LASER DIODE EMISSION CHECK

Never look into the laser diode emission from right above when checking it for adjustment. It is feared that you will lose your sight.

Laser component in this product is capable of emitting radiation exceeding the limit for Class 1.

CLASS 1 LASER PRODUCT
LUOKAN 1 LASERLAITE
KLASS 1 LASERAPPARAT

This appliance is classified as a CLASS 1 LASER product. The CLASS 1 LASER PRODUCT MARKING is located on the rear exterior.

CAUTION : INVISIBLE LASER RADIATION WHEN OPEN AND INTERLOCKS DEFEATED. AVOID EXPOSURE TO BEAM.
ADVARSEL : USYNLIG LASERSTRÅLING VED ÅBNING NÅR SIKKERHEDSAFBRYDERE ER UDE AF FUNKTION. UNDGÅ UDSAETTELSE FOR STRÅLING.
VORSICHT : UNSICHTBARE LASERSTRÄHLUNG, WENN ABDECKUNG GEÖFFNET UND SICHERHEITSVERRIEGELUNG ÜBERBRÜCKT. NICHT DEM STRAHL AUSSETZEN.
VARO! : AVATTAESSA JA SUOJALUKITUS OHITETTAESSA OLET ALTIINA NÄKYMÄTTÖMÄLLE LASERSÄTEILYLLE. ÄLÄ KATSO SÄTEESEEN.
VARNING : OSYNLIG LASERSTRÅLING NÄR DENNA DEL ÄR ÖPPNAD OCH SPÄRREN ÄR URKOPPLAD. BETRÄKTA EJ STRÅLEN.
ADVERSEL : USYNLIG LASERSTRÅLING NÄR DEKSEL ÅPNES OG SIKKERHEDSLÅS BRYTES. UNNGÅ EKSPONERING FOR STRÅLEN.
VIGYAZAT! : A BURKOLAT NYITÁSÁKOR LÁTHATATLAN LÉZERSUGÁRVESZÉLY! KERÜLJE A BESUGÁRZÁST!

This caution label is located inside the unit.

CAUTION

Use of controls or adjustments or performance of procedures other than those specified herein may result in hazardous radiation exposure.

Notes on chip component replacement

- Never reuse a disconnected chip component.
- Notice that the minus side of a tantalum capacitor may be damaged by heat.

Flexible Circuit Board Repairing

- Keep the temperature of soldering iron around 270°C during repairing.
- Do not touch the soldering iron on the same conductor of the circuit board (within 3 times).
- Be careful not to apply force on the conductor when soldering or unsoldering.

SAFETY-RELATED COMPONENT WARNING!!

COMPONENTS IDENTIFIED BY MARK \triangle OR DOTTED LINE WITH MARK \triangle ON THE SCHEMATIC DIAGRAMS AND IN THE PARTS LIST ARE CRITICAL TO SAFE OPERATION. REPLACE THESE COMPONENTS WITH SONY PARTS WHOSE PART NUMBERS APPEAR AS SHOWN IN THIS MANUAL OR IN SUPPLEMENTS PUBLISHED BY SONY.

CAUTION

Danger of explosion if battery is incorrectly replaced.
 Replace only with the same or equivalent type recommended by the manufacturer.
 Discard used batteries according to the manufacturer's instructions.

ADVARSEL!

Lithiumbatteri-Eksplosjonsfare ved feilagtig håndtering.
 Udsiftingning må kun ske med batteri af samme fabrikat og type.
 Levér det brugte batteri tilbage til leverandøren.

ADVARSEL

Ekspløsjonsfare ved feilaktig skifte av batteri.
 Benytt samme batteritype eller en tilsvarende type anbefalt av apparatfabrikanten.
 Brukte batterier kasseres i henhold til fabrikantens instruksjoner.

WARNING

Explosionsfara vid felaktigt batteribyte.
 Använd samma batterityp eller en likvärdig typ som rekommenderas av apparattillverkaren.
 Kassera använt batteri enligt gällande föreskrifter.

VAROITUS

Paristo voi räjähtää, jos se on virheellisesti asennettu.
 Vaihda paristo ainoastaan laitevalmistajan suosittelemaan tyyppiin.
 Hävitä käytetty paristo valmistajan ohjeiden mukaisesti.

SELF-DIAGNOSIS FUNCTION

The self-diagnosis function consists of error codes for customers which are displayed automatically when errors occur, and error codes which show the error history in the test mode during servicing. For details on how to view error codes for the customer, refer to the following box in the instruction manual. For details on how to check error codes during servicing, refer to the following "Procedure for using the Self-Diagnosis Function (Error History Display Mode)".

Self-diagnosis function

The deck's self-diagnosis function automatically checks the condition of the MD deck when an error occurs, then issues a three- or five-digit code and an error message on the display. If the code and message alternate, find them in the following table and perform the indicated countermeasure. Should the problem persist, consult your nearest Sony dealer.

Three- or five-digit code/ Message	Cause/Remedy
C11/Protected	➔ Take out the MD and close the record-protect slot.
C12/Cannot Copy	You tried to record a CD with a format that the external device connected to the deck does not support, such as CD-ROM or video CD. ➔ Remove the disc and insert a music CD.
C13/REC Error	➔ Set the deck in a stable surface, and repeat the recording procedure.
	The inserted MD is dirty (with smudges, fingerprints, etc.), scratched, or substandard in quality. ➔ Replace the disc and repeat the recording procedure.
C13/Read Error	➔ Take out the MD and insert it again.

Three- or five-digit code/ Message	Cause/Remedy
C14/Toc Error	➔ Insert another disc. ➔ If possible, erase all the tracks on the MD.
C41/Cannot Copy	The sound source is a copy of commercially available music software, or you tried to record a CD-R (Recordable CD). ➔ The Serial Copy Management System prevents making a digital copy. You cannot record a CD-R.
C71/Din Unlock	The sporadic appearance of this message is caused by the digital signal being recorded. This will not affect the recording.
	While recording from a digital component connected through the DIGITAL IN connector, the digital connecting cable was unplugged or the digital component turned off. ➔ Connect the cable or turn the digital component back on.
E0001/MEMORY NG	There is an error in the internal data that the deck needs in order to operate. ➔ Consult your nearest Sony dealer.
E0101/LASER NG	There is a problem with the optical pickup. ➔ The optical pick-up may have failed. Consult your nearest Sony dealer.
E0201/LOADING NG	There is a problem with the loading. ➔ The loading may have failed. Consult your nearest Sony dealer.

Procedure for using the Self-Diagnosis Function (Error History Display Mode).

Note: Perform the self-diagnosis function in the "error history display mode" in the test mode. The following describes the least required procedure. Be careful not to enter other modes by mistake. If you set other modes accidentally, press the **[MENU/NO]** button to exit the mode.

MDS-JE480

1. While pressing the **◀◀AMS▶▶** knob and **■** button, connect the power plug to the outlet, and release the **◀◀AMS▶▶** knob and **■** button.
When the test mode is set, “[Check]” will be displayed.
2. Rotate the **◀◀AMS▶▶** knob and when “[Service]” is displayed, press the **YES** button.
3. Rotate the **◀◀AMS▶▶** knob and display “Err Display”.
4. Pressing the **YES** button sets the error history mode and displays “op rec tm”.
5. Select the contents to be displayed or executed using the **◀◀AMS▶▶** knob.
6. Pressing the **◀◀AMS▶▶** knob will display or execute the contents selected.
7. Pressing the **◀◀AMS▶▶** knob another time returns to step 4.
8. Pressing the **MENU/NO** button displays “Err Display” and exits the error history mode.
9. To exit the test mode, press the **REPEAT** button. The unit sets into the STANDBY state, the disc is ejected, and the test mode ends.

ITEMS OF ERROR HISTORY MODE ITEMS AND CONTENTS

Selecting the Test Mode

Display	History
op rec tm	Displays the total recording time. When the total recording time is more than 1 minute, displays the hour and minute When less than 1 minute, displays “Under 1 min” The display time is the time the laser is set to high power, which is about 1/4 of the actual recording time.
op play tm	Displays the total playback time. When the total playback time is more than 1 minute, displays the hour and minute When less than 1 minute, displays “Under 1 min”
spdl rp tm	Displays the total rotating time of the spindle motor. When the total rotating time is more than 1 minute, displays the hour and minute When less than 1 minute, displays “Under 1 min”
retry err	Displays the total number of retry errors during recording and playback Displays “r xx p yy”. xx is the number of errors during recording. yy is the number of errors during playback. This is displayed in hexadecimal from 00 to FF.
total err	Displays the total number of errors Displays “total xx”. This is displayed in hexadecimal from 00 to FF.
err history	Displays the past ten errors. Displays “0x ErrCd@@”. X is the history number. The younger the number, the more recent is the history (00 is the latest). @@ is the error code. Select the error history number using the ◀◀AMS▶▶ knob.
retry adrs	Displays the past five retry addresses. Displays “xx ADRS yyyy”, xx is the history number, yyyy is the cluster with the retry error. Select the error history number using the ◀◀AMS▶▶ knob.
er refresh	Mode for erasing the error and retry address histories Procedure 1. Press the ◀◀AMS▶▶ knob when displayed as “er refresh”. 2. Press the YES button when the display changes to “er refresh?”. When “complete!” is displayed, it means erasure has completed. Be sure to check the following after executing this mode. *Data has been erased. *Perform recording and playback, and check that the mechanism is normal.
tm change	Mode for erasing the total time of recording and playback Procedure 1. Press the ◀◀AMS▶▶ knob when displayed as “tm refresh”. 2. Press the YES button when the display changes to “tm refresh?”. When “complete!” is displayed, it means erasure has completed.
op change	Mode for erasing the total time of op rec tm, op play tm. These histories are based on the time of replacement of the optical pickup. If the optical pick-up has been replaced, perform this procedure and erase the history. Procedure 1. Press the ◀◀AMS▶▶ knob when displayed as “op change”. 2. Press the YES button when the display changes to “op chang?”. When “Complete!” is displayed, it means erasure has completed.

Display	History
spdl change	<p>Mode for erasing the total spdl rp tm time These histories are based on the time of replacement of the spindle motor. If the spindle motor has been replaced, perform this procedure and erase the history.</p> <p>Procedure</p> <ol style="list-style-type: none"> 1. Press the ◀◀AMS▶▶ knob when displayed as “spdl change” 2. Press the YES button when the display changes to “spdl chang?” <p>When “Complete!” is displayed, it means erasure has completed.</p>

Table of Error Codes

Error Code	Description
10	Could not load
12	Loading switches combined incorrectly
20	Timed out without reading the top of PTOC
21	Could read top of PTOC, but detected error
22	Timed out without accessing UTOC
23	Timed out without reading UTOC
24	Error in UTOC
30	Could not start playback
31	Error in sector
40	Retry cause generated during normal recording
41	Retried in DRAM overflow
42	Retry occurred during TOC writing
43	Retry aborted during S.F editing
50	Other than access processing, and could not read address.
51	Focus NG occurred and overran.

MODEL IDENTIFICATION
— BACK PANEL —

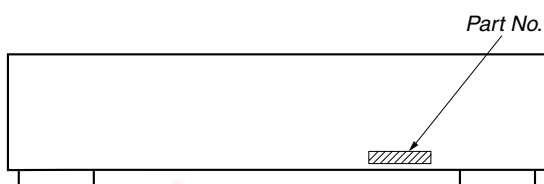

MODEL	PARTS No.
US model	4-238-633-0□
AEP and Russian models	4-238-633-5□
UK model	4-238-633-6□

TABLE OF CONTENTS

1. SERVICING NOTES 6

2. GENERAL 12

3. DISASSEMBLY

3-1. Disassembly flow 13

3-2. Upper Case (408226) 14

3-3. Front Panel Section 14

3-4. Main Board 15

3-5. PT Board 15

3-6. Mechanism Deck Section (MDM-7S1A) 16

3-7. Over Light Head (HR901), BD Board 16

3-8. Holder Assy 17

3-9. Loading Motor Assy (M103) 17

3-10. Sled Motor Assy (M102), Slider 18

3-11. Optical Pick-up 18

3-12. Spindle Motor Assy (M101) 19

4. TEST MODE20

5. ELECTRICAL ADJUSTMENTS 25

6. DIAGRAMS

6-1. Circuit Boards Location 36

6-2. Block Diagrams

- BD Section 38
- Main Section 39

6-3. Printed Wiring Board – BD Board – 40

6-4. Schematic Diagram – BD Section (1/2) – 41

6-5. Schematic Diagram – BD Section (2/2) – 42

6-6. Schematic Diagram – Main Section (1/2) – 43

6-7. Schematic Diagram – Main Section (2/2) – 44

6-8. Printed Wiring Board – Main Section – 45

6-9. Printed Wiring Board – Display Section – 46

6-10. Schematic Diagram – Display Section – 47

6-11. Printed Wiring Board – Power Section – 48

6-12. Schematic Diagram – Power Section – 48

6-13. IC Pin Function Discription 49

6-14. IC Block Diagrams 55

7. EXPLODED VIEWS

7-1. Chassis Section 58

7-2. Front Panel Section 59

7-3. Mechanism Section-1 (MDM-7S1A) 60

7-4. Mechanism Section-2 (MDM-7S1A) 61

8. ELECTRICAL PARTS LIST 62

SECTION 1 SERVICE NOTES

JIG FOR CHECKING BD BOARD WAVEFORM

The special jig (J-2501-196-A) is useful for checking the waveform of the BD board. The names of terminals and the checking items to be performed are shown as follows.

- GND : Ground
- I+3V : For measuring Iop (Check the deterioration of the optical pick-up laser)
- Iop : For measuring Iop (Check the deterioration of the optical pick-up laser)
- TE : TRK error signal (Traverse adjustment)
- VC : Reference level for checking the signal
- RF : RF signal (Check jitter)
- FE : Focus error signal

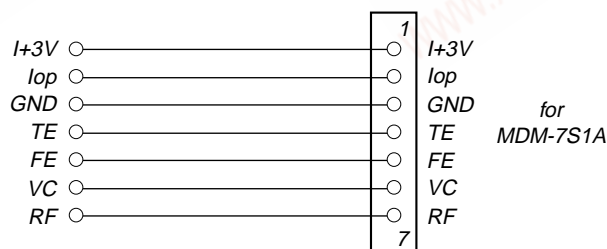
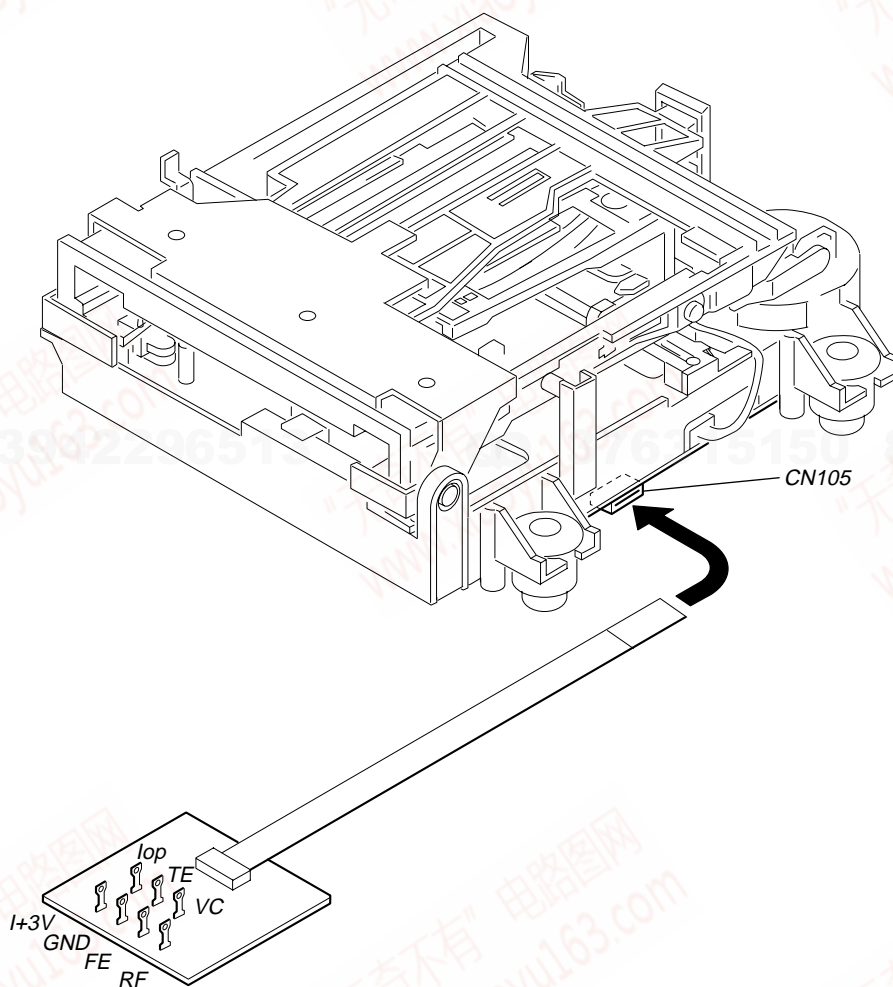

Top DATA RECORDING AND DISPLAY WHEN OPTICAL PICK-UP AND NON-VOLATILE MEMORY (IC195 OF BD BOARD) ARE REPLACED

The Top value labeled on the optical pick-up can be recorded in the non-volatile memory. By recording the value, it will eliminate the need to look at the value on the label of the optical pick-up. When replacing the optical pick-up or non-volatile memory (IC195 of BD board), record the Top value on the optical pick-up according to the following procedure.

Record Procedure:

1. While pressing the **◀◀AMS▶▶** knob and **■** button, connect the power plug to the outlet, and release the **◀◀AMS▶▶** knob and **■** button.
2. Rotate the **◀◀AMS▶▶** knob to display “[Service]”, and press the **YES** button.
3. Rotate the **◀◀AMS▶▶** knob to display “Iop Write” (C05), and press the **YES** button.
4. The display becomes “Ref=@@.@” (@ is an arbitrary number) and the numbers which can be changed will blink.
5. Input the Iop value written on the optical pick-up.
To select the number : Rotate the **◀◀AMS▶▶** knob.
To select the digit : Press the **◀◀AMS▶▶** knob.
6. When the **YES** button is pressed, the display becomes “Measu=@@.@” (@ is an arbitrary number).
7. As the adjustment results are recorded for the 6 value. Leave it as it is and press the **YES** button.
8. “Complete!” will be displayed momentarily. The value will be recorded in the non-volatile memory and the display will become “Iop Write”.
9. Press the **REPEAT** button to complete.

Display Procedure:

1. While pressing the **◀◀AMS▶▶** knob and **■** button, connect the power plug to the outlet, and release the **◀◀AMS▶▶** knob and **■** button.
2. Rotate the **◀◀AMS▶▶** knob to display “[Service]”, and press the **YES** button.
3. Rotate the **◀◀AMS▶▶** knob to display “Iop Read” (C26).
4. “@@.@/##.#” is displayed and the recorded contents are displayed.
@@.@ : indicates the Iop value labeled on the optical pick-up.
##.# : indicates the Iop value after adjustment
5. To end, press the **◀◀AMS▶▶** button or **MENU/NO** button to display “Iop Read”. Then press the **REPEAT** button.

MDS-JE480

OPTICAL PICK-UP BLOCK TYPE DISCRIMINATION

There are two types of the optical pick-up block in this model. These are compatible except for the laser power. Check the type of the optical pick-up block before replacement. Adjust following items after replacing the optical pick-up block.

- 5-6-2. Laser Power Check (See page 28)
- 5-10. LASER POWER ADJUSTMENT (See page 31)

Differences

	KMS-260B	KMS-260E
Color of the adhesive agent at PDIC portion	Pink	White
Form of FPC retainer plate	Close the hole on SL base	Not close the hole on SL base
APC variable resistor	Small volume (2 type)	Big variable resistor (3 type) and chip resistor (Fig. A) Small variable resistor (2 type) and chip resistor (Fig. B)

Fig. B type is for repair.

• Abbreviation

260B: KMS-260B model

260E: KMS-260E model

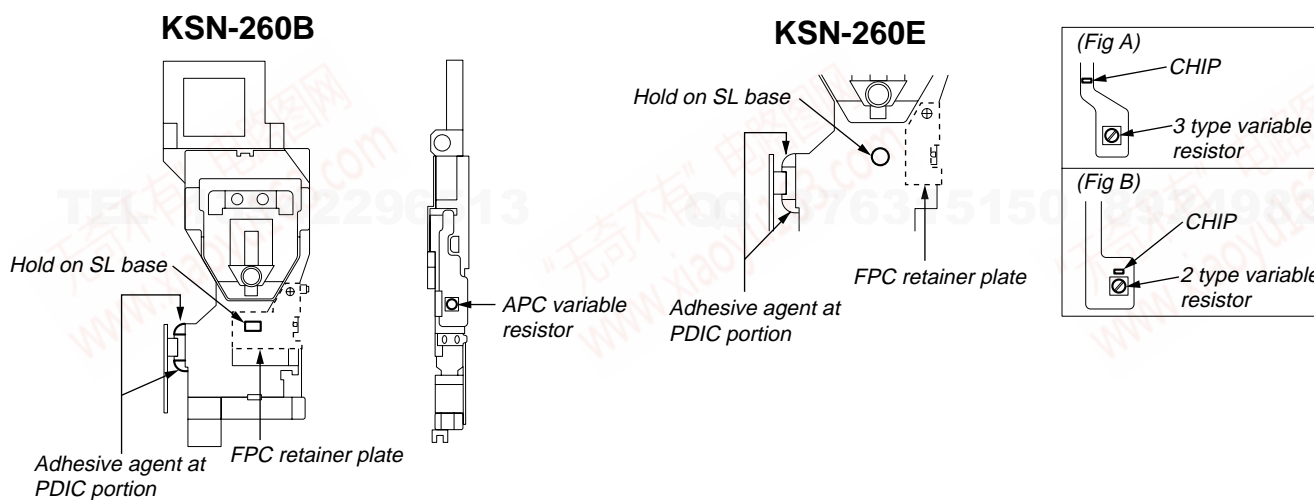

CHECKS PRIOR TO PARTS REPLACEMENT AND ADJUSTMENTS

Before performing repairs, perform the following checks to determine the faulty locations up to a certain extent. Details of the procedures are described in "5 Electrical Adjustments".

- 5-6-2. Laser power check (see page 28)
- 5-6-3. Iop Compare (see page 28)
- 5-6-4. Auto Check (see page 29)

Note:

The criteria for determination above is intended merely to determine if satisfactory or not, and does not serve as the specified value for adjustments.

When performing adjustments, use the specified values for adjustments.

FORCED RESET

The system microprocessor can be reset in the following procedure.

Use these procedure when the unit cannot be operated normally due to the overrunning of the microprocessor, etc.

Procedure :

Remove the short-pin attached to CN406, and then attach it again.

[MAIN BOARD] (Component Side)

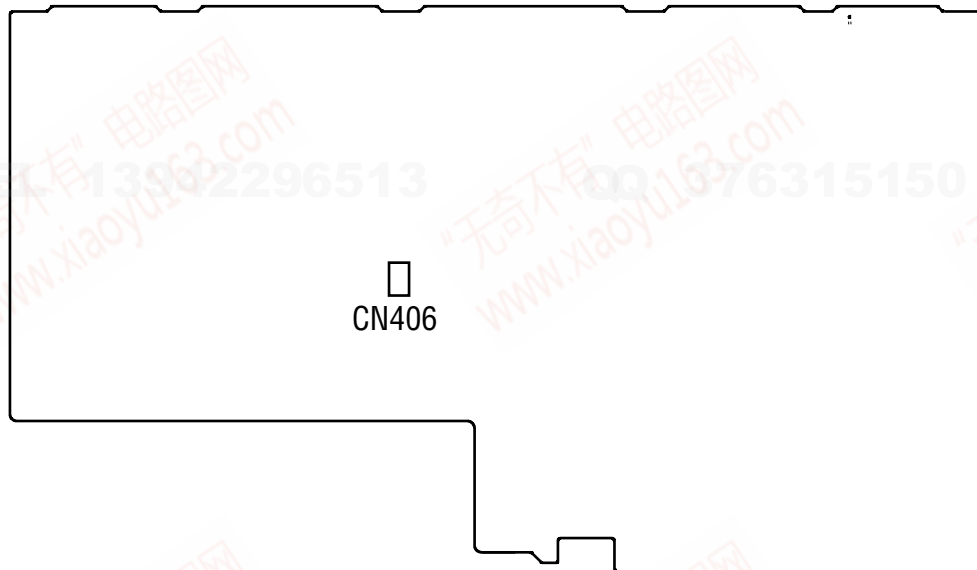

RETRY CAUSE DISPLAY MODE

- In this test mode, the causes for retry of the unit during recording can be displayed on the fluorescent indicator tube. During playback, the “track mode” for obtaining track information will be set. This is useful for locating the faulty part of the unit.
- The following will be displayed :
 During recording and stop : Retry cause, number of retries, and number of retry errors.
 During playback : Information such as type of disc played, part played, copyright.
 These are displayed in hexadecimal.

Procedure:

1. Insert the recordable disc.
2. Press **MENU/NO** button to display “Edit Menu” on the fluorescent display.
3. Turn **◀◀ AMS ▶▶** button to display “All Erase?” on the fluorescent display.
4. Press **YES** button to display “All Erase??” on the fluorescent display.
5. Press **YES** button, “Complete!” is displayed on the fluorescent display and it turns off immediately.
6. Procedure 1: Press the **■** button continuously for about 10 seconds.
 Procedure 2: Press the **LEVEL/DISPLAY/CHAR** button while pressing the **■** button and **MENU/NO** button.
7. When the mode is set, “RTs 00c 00e 000” is displayed.
8. Press the **● REC** button to start recording. Then press the **||** button and start recording.
9. To check the “track mode”, press the **▷** button to start play.
10. To exit the test mode, press the **I/O** button, and turn OFF the power. When “TOC” disappears, disconnect the power plug from the outlet.
 If the test mode cannot be exited, refer to “Forced Reset” on page 9.

Fig. 1 Reading the Test Mode Display (During recording and stop)

RTs@@c###e***

Fluorescent display tube display

- @@ : Cause of retry
- ## : Number of retries
- *** : Number of retry errors

Fig. 2 Reading the Test Mode Display (During playback)

@@###**\$\$

Fluorescent display tube display

- @@ : Parts No. (name of area named on TOC)
- ### : Cluster } Address (Physical address on disc)
- ** : Sector
- \$\$: Track mode (Track information such as copyright information of each part)

Reading the Retry Cause Display

Hexadecimal	Higher Bits				Lower Bits				Hexadecimal	Cause of Retry	Occurring conditions
	8	4	2	1	8	4	2	1			
Bit	b7	b6	b5	b4	b3	b2	b1	b0			
Binary	0	0	0	0	0	0	0	1	01	shock	When track jump (shock) is detected
	0	0	0	0	0	0	1	0	02	ader5	When ADER was counted more than five times continuously
	0	0	0	0	0	1	0	0	04	Discontinuous address	When ADIP address is not continuous
	0	0	0	0	1	0	0	0	08	DIN unlock	When DIN unlock is detected
	0	0	0	1	0	0	0	0	10	FCS incorrect	When not in focus
	0	0	1	0	0	0	0	0	20	IVR rec error	When ABCD signal level exceeds the specified range
	0	1	0	0	0	0	0	0	40	CLV unlock	When CLV is unlocked
	1	0	0	0	0	0	0	0	80	Access fault	When access operation is not performed normally

Reading the Display:

Convert the hexadecimal display into binary display. If more than two causes, they will be added.

Example

When 42 is displayed:

Higher bit : 4 = 0100 → b6

Lower bit : 2 = 0010 → b1

In this case, the retry cause is combined of “CLV unlock” and “ader5”.

When A2 is displayed:

Higher bit : A = 1010 → b7+b5

Lower bit : 2 = 0010 → b2

The retry cause in this case is combined of “access fault”, “TVR rec error”, and “ader5”.

Reading the Track Mode Display

Hexadecimal	Higher Bits				Lower Bits				Hexa-decimal	Details	
	8	4	2	1	8	4	2	1		When 0	When 1
Bit	b7	b6	b5	b4	b3	b2	b1	b0			
Binary	0	0	0	0	0	0	0	1	01	Emphasis OFF	Emphasis ON
	0	0	0	0	0	0	1	0	02	Monaural	Stereo
	0	0	0	0	0	1	0	0	04	This is 2-bit display. Normally 01.	
	0	0	0	0	1	0	0	0	08	01:Normal audio. Others:Invalid	
	0	0	0	1	0	0	0	0	10	Audio (Normal)	Invalid
	0	0	1	0	0	0	0	0	20	Original	Digital copy
	0	1	0	0	0	0	0	0	40	Copyright	No copyright
	1	0	0	0	0	0	0	0	80	Write prohibited	Write allowed

Reading the Display:

Convert the hexadecimal display into binary display. If more than two causes, they will be added.

Example When 84 is displayed:

Higher bit : 8 = 1000 → b7

Lower bit : 4 = 0100 → b2

In this case, as b2 and b7 are 1 and others are 0, it can be determined that the retry cause is combined of “emphasis OFF”, “monaural”, “original”, “copyright exists”, and “write allowed”.

Example When 07 is displayed:

Higher bit : 0 = 1000 → All 0

Lower bit : 7 = 0111 → b0+b1+b2

In this case, as b0, b1, and b2 are 1 and others are 0, it can be determined that the retry cause is combined of “emphasis ON”, “stereo”, “original”, “copyright exists”, and “write prohibited”.

Hexadecimal → Binary Conversion Table

Hexadecimal	Binary	Hexadecimal	Binary
0	0000	8	1000
1	0001	9	1001
2	0010	A	1010
3	0011	B	1011
4	0100	C	1100
5	0101	D	1101
6	0110	E	1110
7	0111	F	1111

SECTION 2 GENERAL

This section is extracted from instruction manual.

Main unit

ALPHABETICAL ORDER

A - M

- AMS **19** (10) (16) (18) (21) (23) (25)
- CLEAR **18** (17) (22)
- Display window **13**
- EJECT **4** (8) (16) (17)
- INPUT **14** (8)
- LEVEL/DISPLAY/CHAR **12** (8) (16) (21)
- MD (insertion slot) **2**
- MDLP (indicator) **3** (9) (16)
- MENU/NO **8** (9) (10) (11) (21)

P - Z

- PLAY MODE **10** (15)
- PUSH ENTER **19** (10)
- REC MODE **16** (9) (16)
- REC **17** (8)
- REPEAT **11** (15)
- STANDBY (indicator) **1** (8) (15)
- YES **9** (16)

BUTTON DESCRIPTIONS

- I/⏻ **1** (8) (15) (17)
- ▷ **5** (8) (15)
- ⏮ **6** (8) (16)
- **7** (8) (16) (17)
- ◀▶ **15** (16) (18)

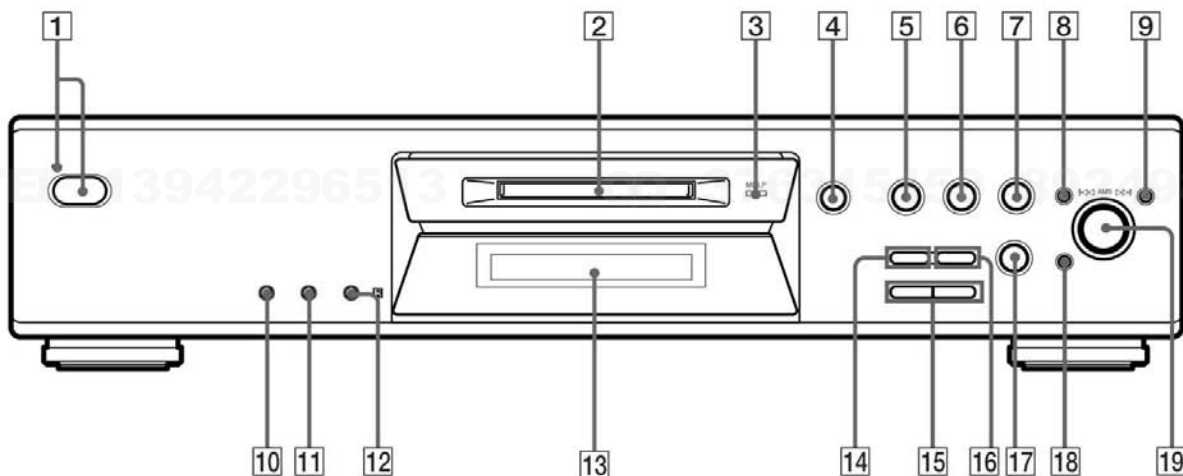

SECTION 3 DISASSEMBLY

• This set can be disassembled in the order shown below.

3-1. DISASSEMBLY FLOW

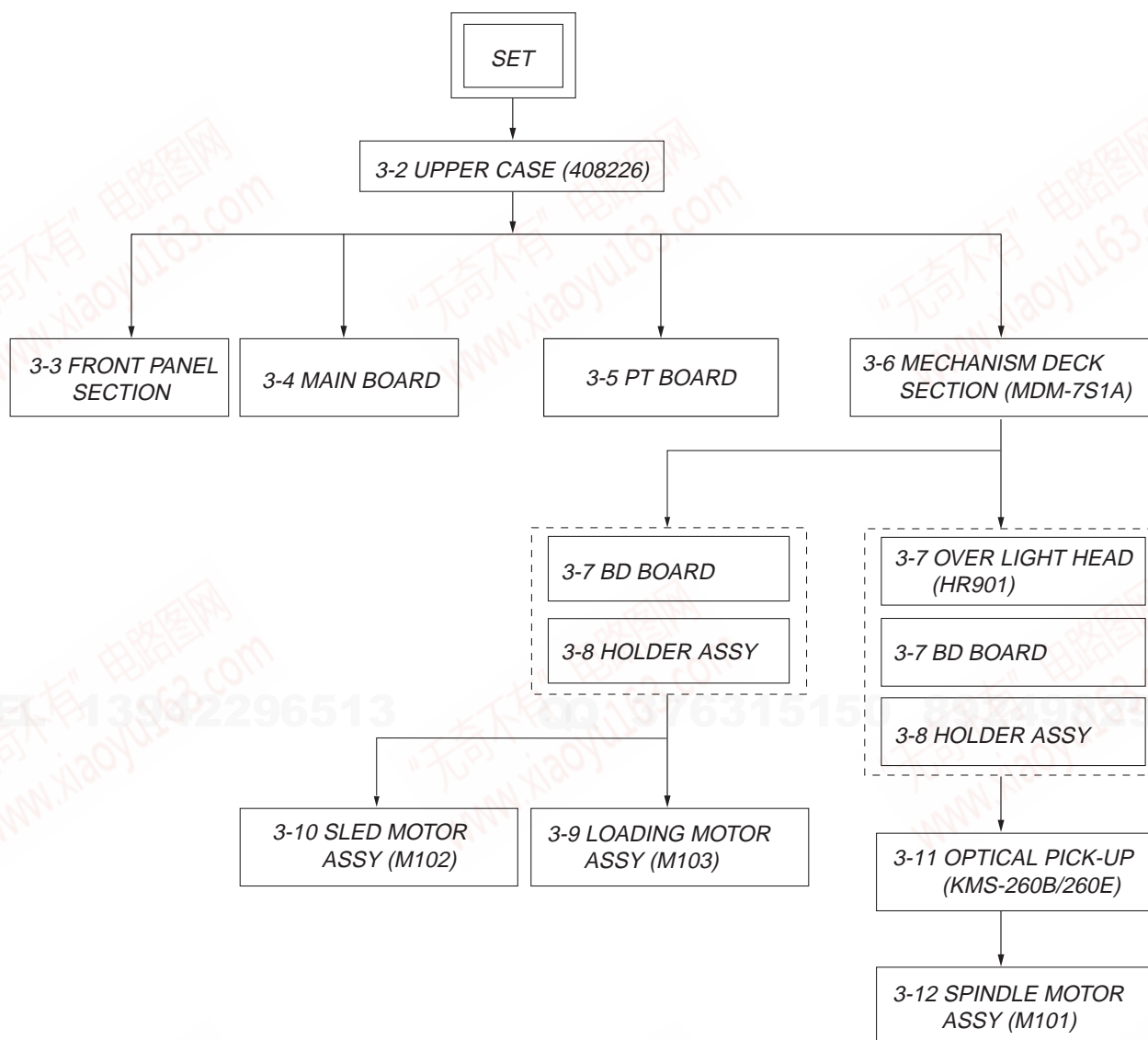

Note 1: The processes enclosed with [- - -], remove in the any order.

Note 2: You cannot go to the next process until every process enclosed with [- - -] has done.

MDS-JE480

3-2. UPPER CASE (408226)

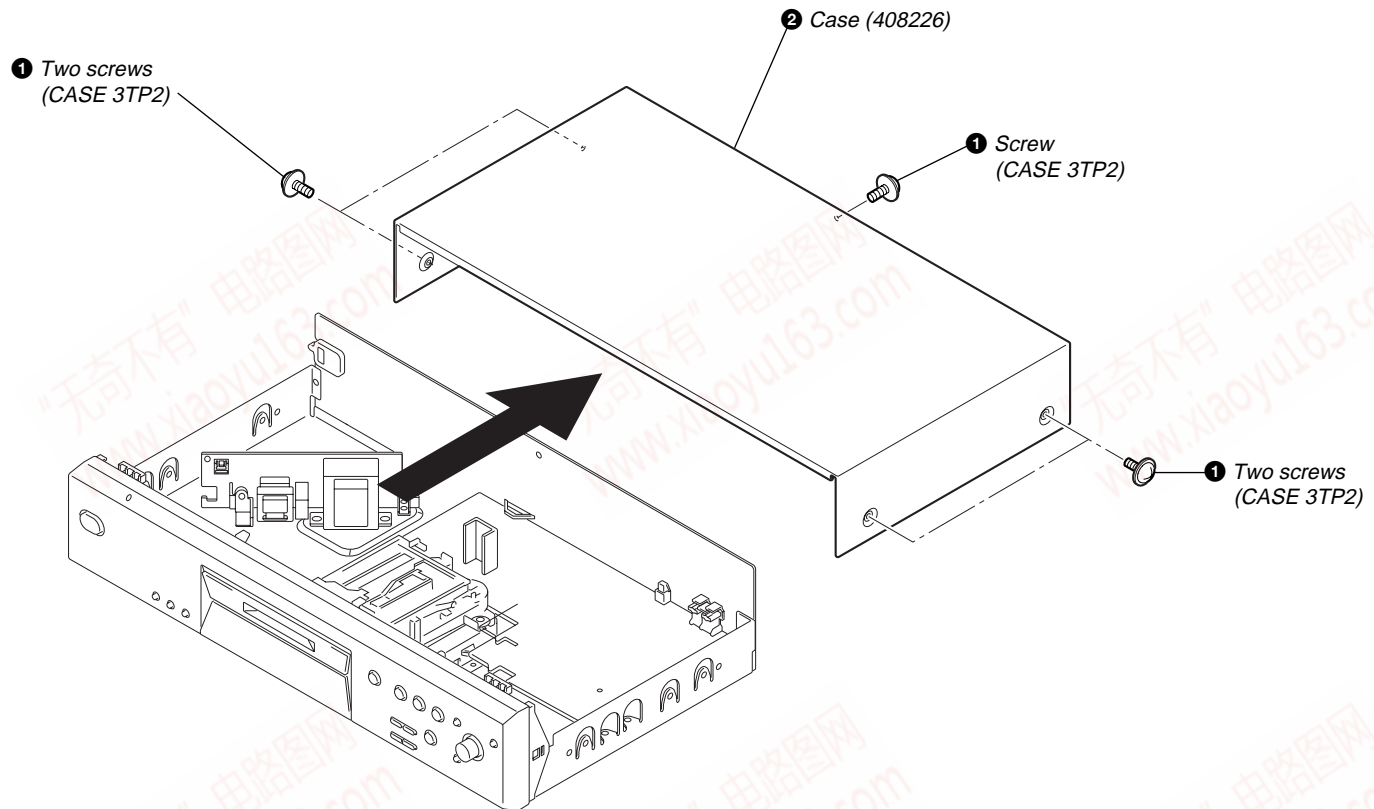

3-3. FRONT PANEL SECTION

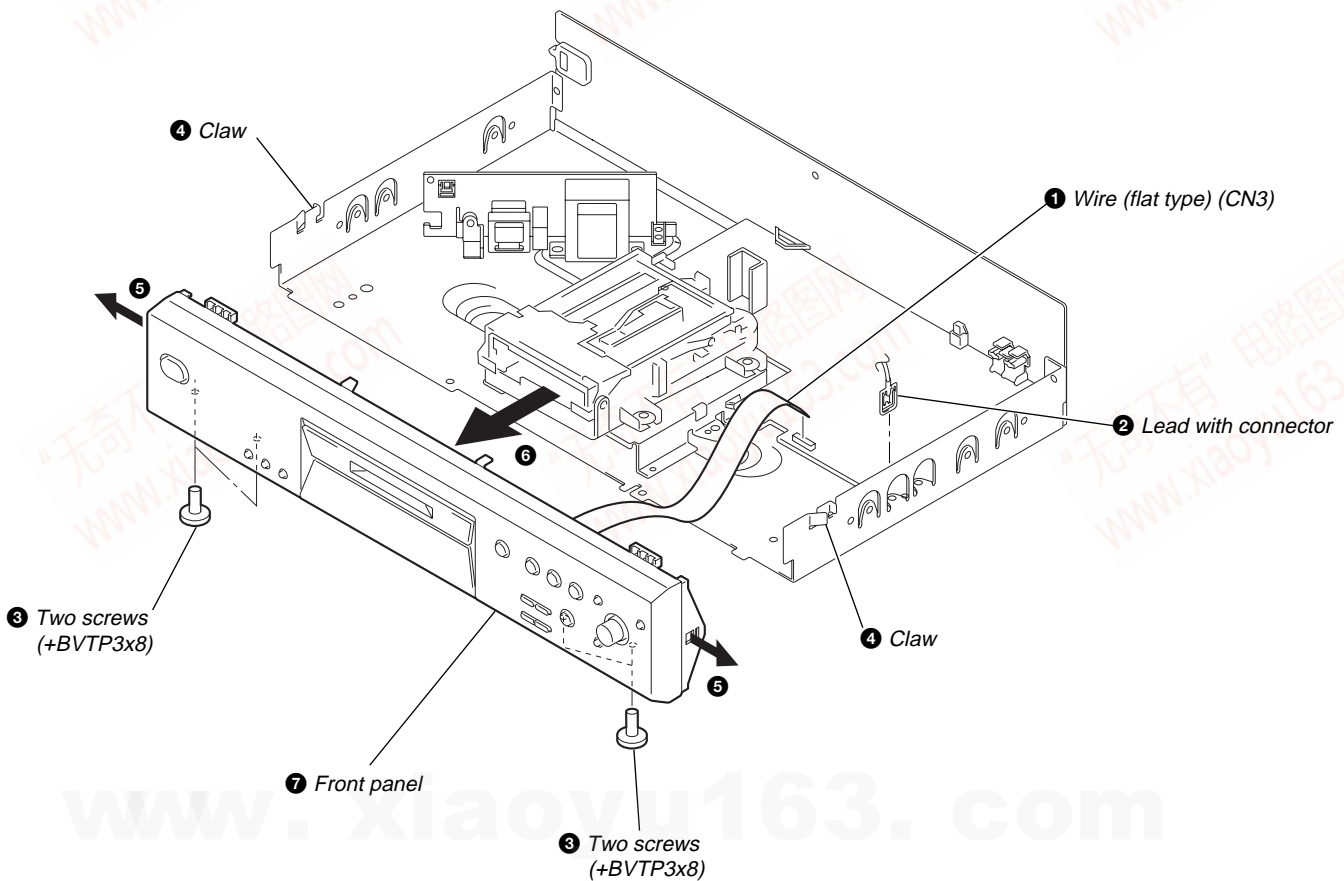

3-4. MAIN BOARD

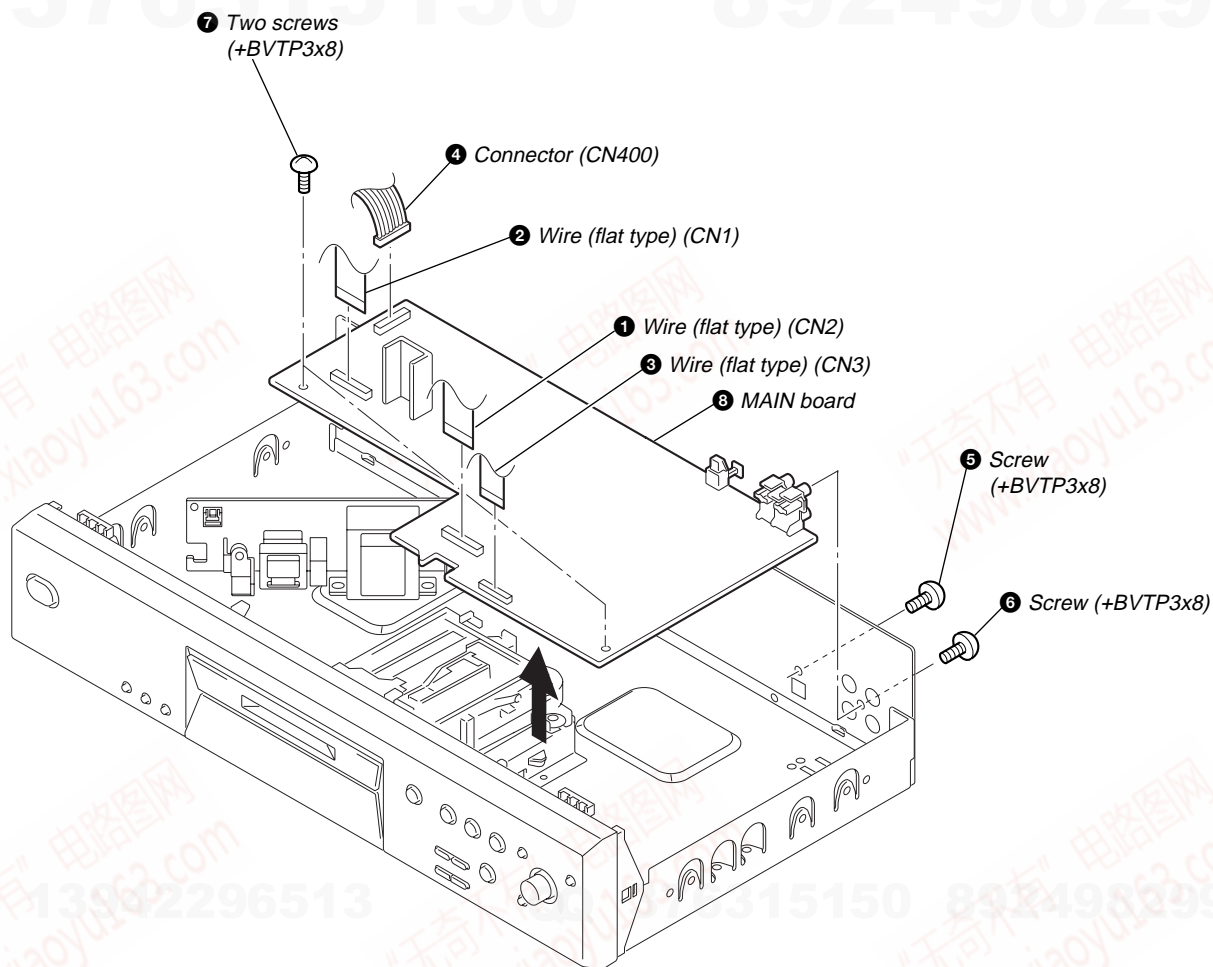

3-5. PT BOARD

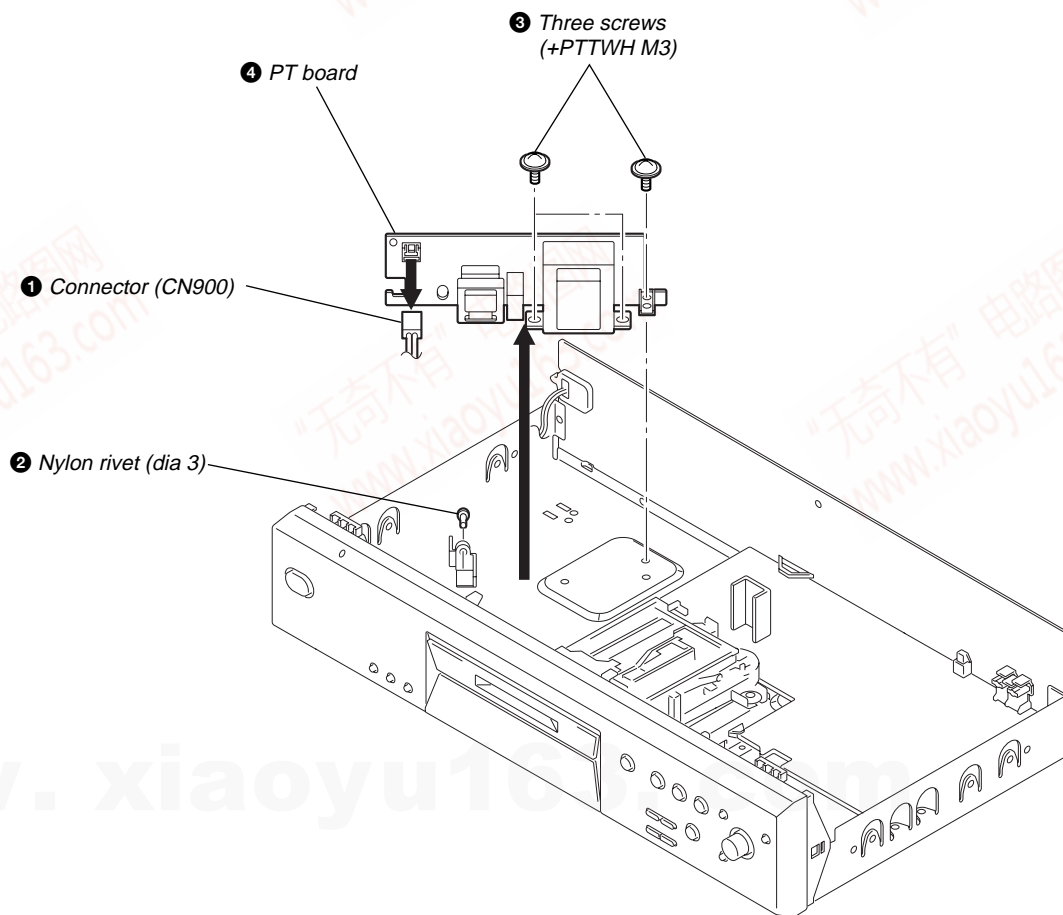

3-6. MECHANISM DECK SECTION (MDM-7S1A)

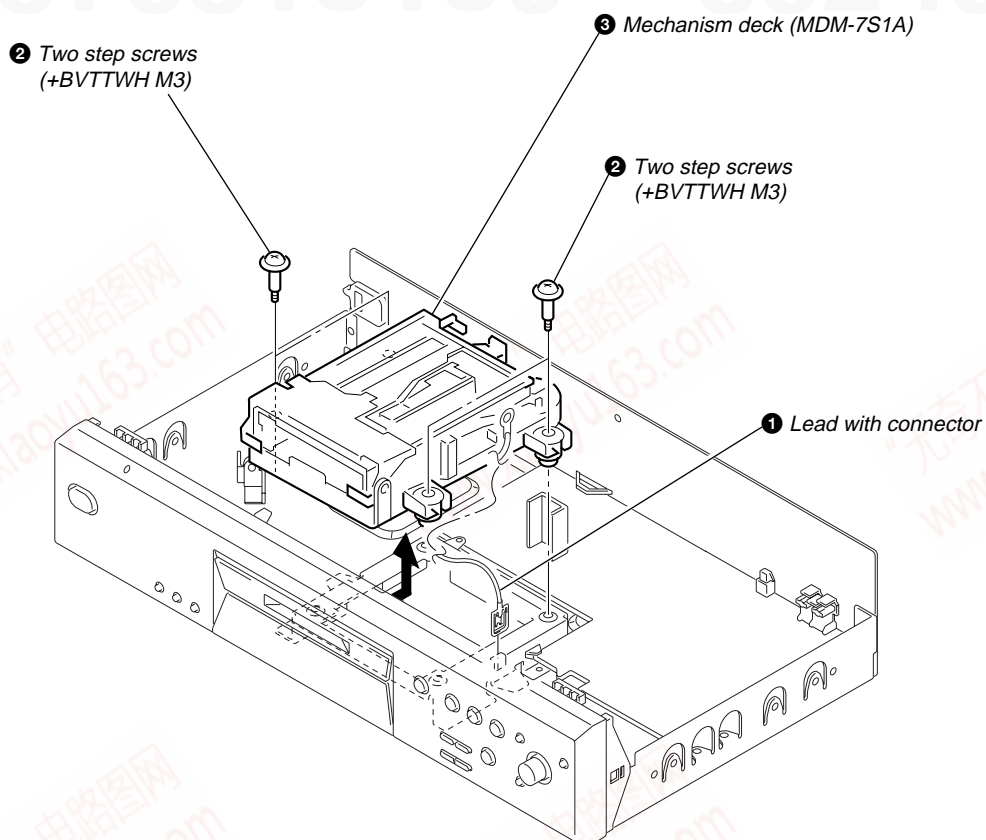

3-7. OVER LIGHT HEAD (HR901), BD BOARD

Note 1: If you disconnect the connector (CN104), you can remove the BD board without removing the over write head (HR901).

Note 2: Be careful to handle the over write head (HR901) because it is easy to be damaged.

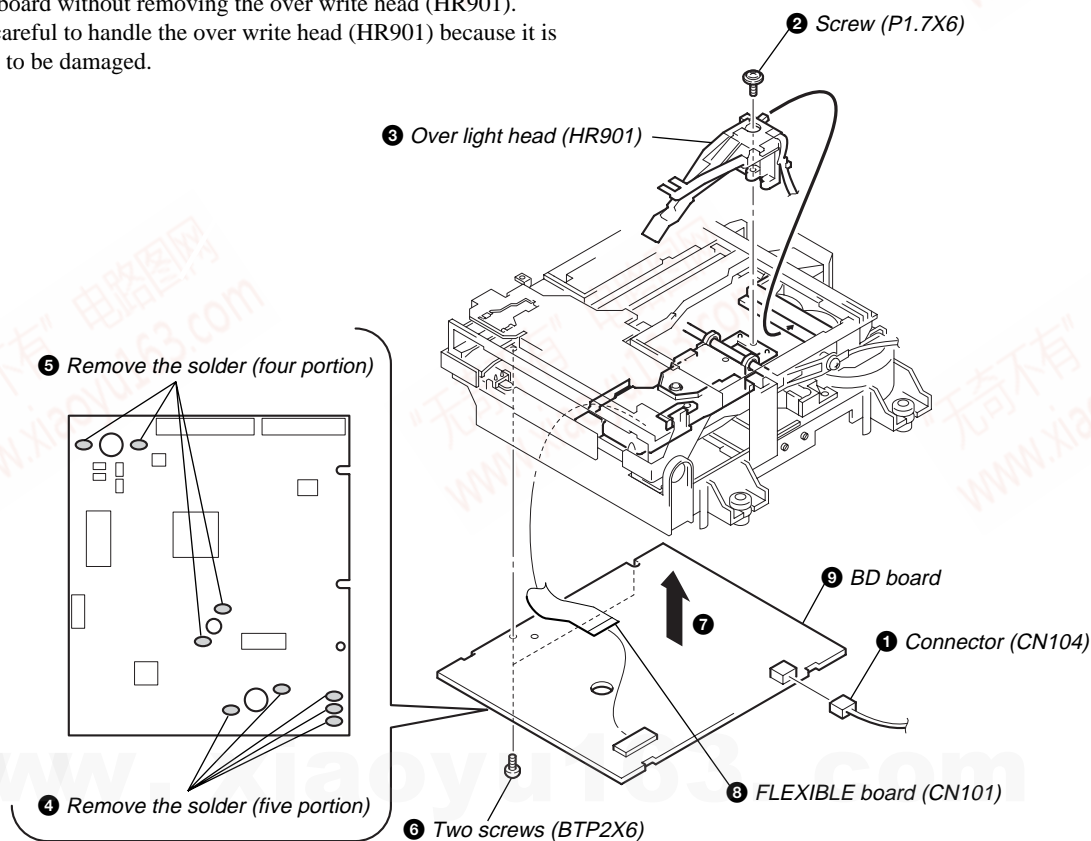

3-8. HOLDER ASSY

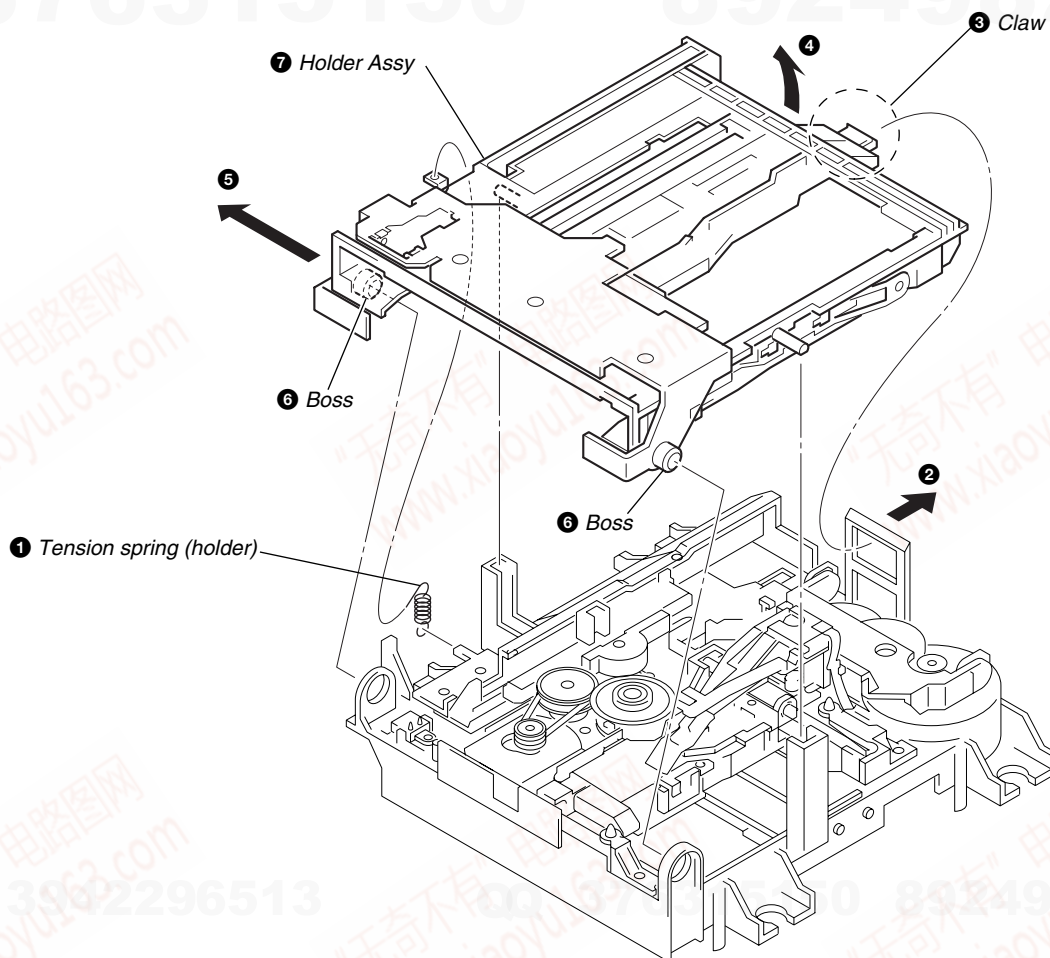

3-9. LOADING MOTOR ASSY (M103)

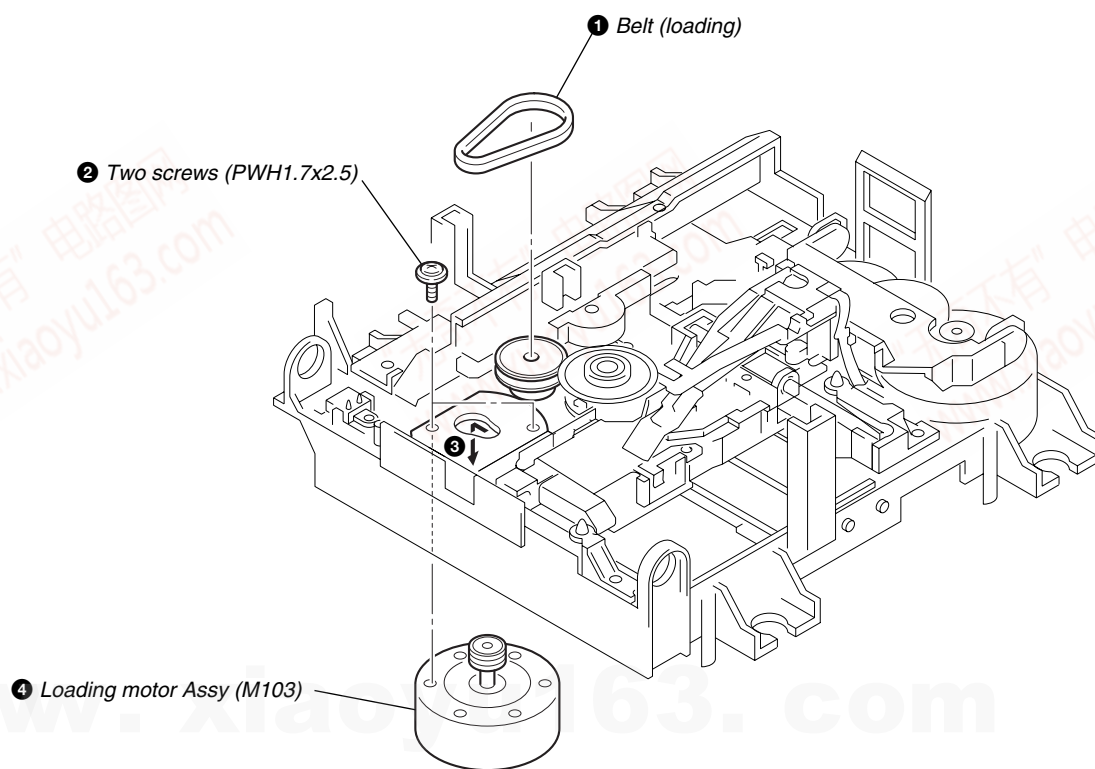

3-10. SLED MOTOR ASSY (M102), SLIDER

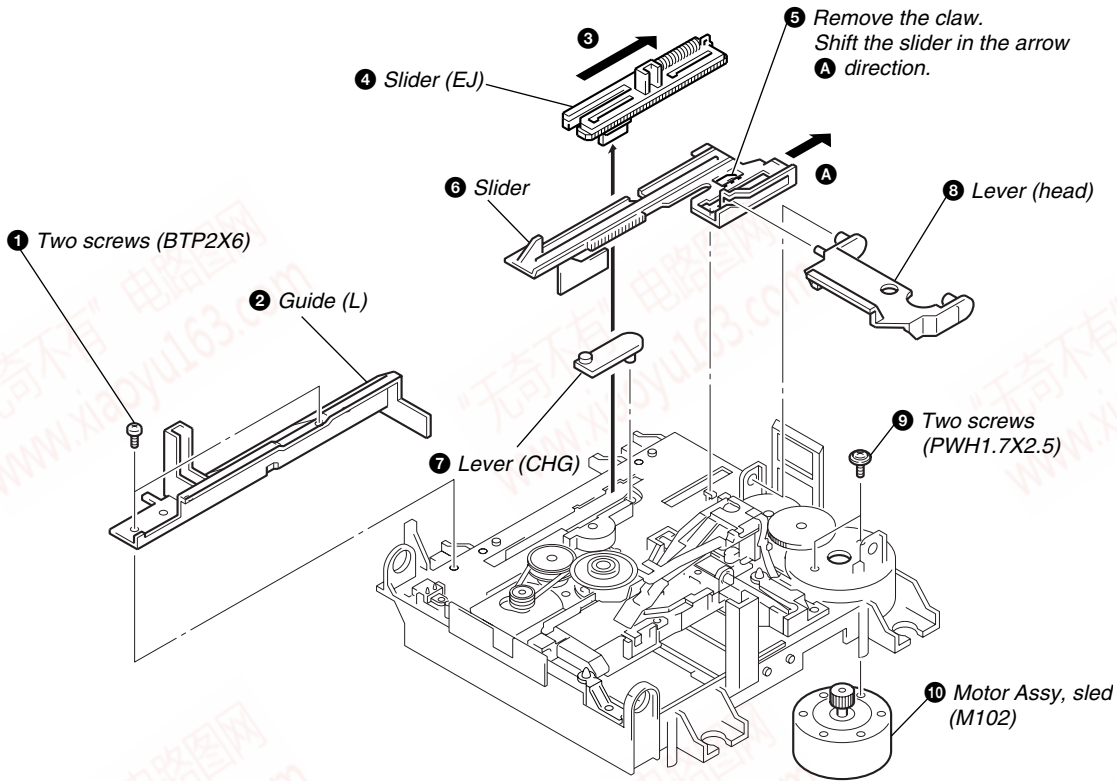

3-11. OPTICAL PICK-UP

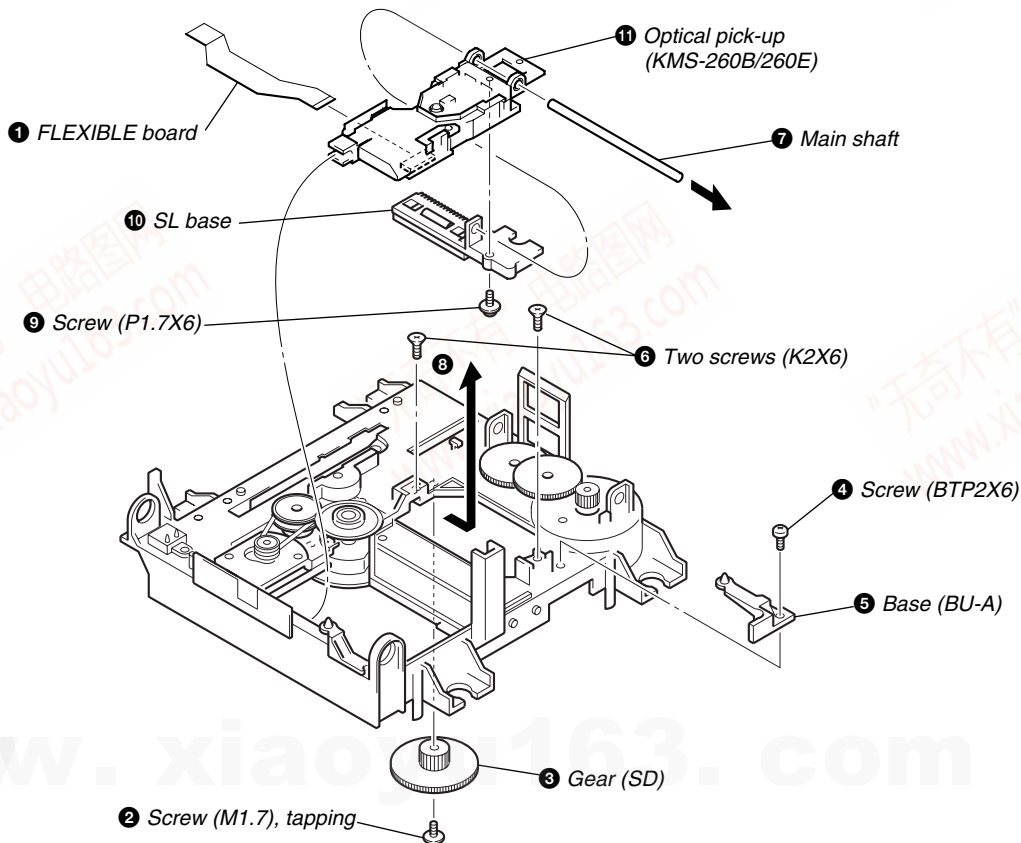

3-12. SPINDLE MOTOR ASSY (M101)

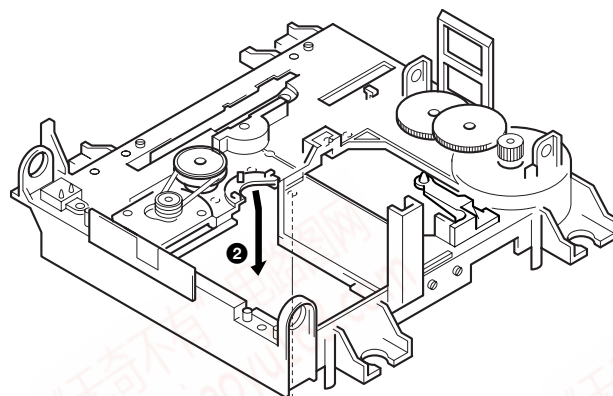

3 Spindle motor Assy (M101)

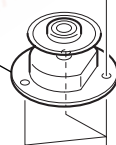

1 Three screws (M1.7), tapping

SECTION 4 TEST MODE

4-1. PRECAUTIONS FOR USE OF TEST MODE

- As loading related operations will be performed regardless of the test mode operations being performed, be sure to check that the disc is stopped before setting and removing it.
Even if the **EJECT** button is pressed while the disc is rotating during continuous playback, continuous recording, etc., the disc will not stop rotating.
Therefore, it will be ejected while rotating.
Be sure to press the **EJECT** button after pressing the **MENU/NO** button and the rotation of disc is stopped.

4-1-1. Recording laser emission mode and operating buttons

- Continuous recording mode (CREC 1MODE) (C35)
- Laser power check mode (LDPWR CHECK) (C13)
- Laser power adjustment mode (LDPWR ADJUST) (C04)
- Iop check (Iop Compare) (C27)
- Iop value nonvolatile writing (Iop NV Save) (C06)
- Traverse (MO) check (EF MO CHECK) (C14)
- Traverse (MO) adjustment (EF MO ADJUST) (C07)
- When pressing the **REC** button.

4-2. SETTING THE TEST MODE

The following are two methods of entering the test mode.

Procedure 1: While pressing the **AMS** knob and **STOP** button, connect the power plug to an outlet, and release the **AMS** knob and **STOP** button.

When the test mode is set, “[Check]” will be displayed. Rotating the **AMS** knob switches between the following three groups; ... ↔ Check ↔ Service ↔ Develop ↔ ...

Procedure 2: While pressing the **AMS** knob, connect the power plug to the outlet and release the **AMS** knob.

When the test mode is set, “TEMP CHECK” will be displayed. By setting the test mode using this method, only the “Check” group of method 1 can be executed.

NOTE: Do not use the test mode in the [Develop] group.

If used, the unit may not operate normally.

If the [Develop] group is set accidentally, press the **MENU/NO** button immediately to exit the [Develop] group.

4-3. EXITING THE TEST MODE

Press the **REPEAT** button. The disc is ejected when loaded, and “Standby” display blinks, and the STANDBY state is set.

4-4. BASIC OPERATIONS OF THE TEST MODE

All operations are performed using the **AMS** knob, **YES** button, and **MENU/NO** button.

The functions of these buttons are as follows.

Function name		Function
MENU/NO button		Cancel or move to top hierarchy
YES button		Set
AMS knob	Left or Right	Select
	Push	Set submenu

4-5. SELECTING THE TEST MODE

There are 25 types of test modes as shown below. The groups can be switched by rotating the \llcorner AMS \lrcorner knob. After selecting the group to be used, press the **YES** button. After setting a certain group, rotating the \llcorner AMS \lrcorner knob switches between these modes. Refer to “Group” in the table for details selected.

All adjustments and checks during servicing can be performed in the test mode in the Service group.

NOTE: Do not use the test mode in the [Develop] group.

If used, the unit may not operate normally.

If the [Develop] group is set accidentally, press the **MENU/NO** button immediately to exit the [Develop] group.

Display	No.	Details	Mark	Group	
				Check	Service
AUTO CHECK	C01	Automatic self-diagnosis			<input type="radio"/>
Err Display	C02	Error history display, clear			<input type="radio"/>
TEMP ADJUST	C03	Temperature compensation offset adjustment			<input type="radio"/>
LDPWR ADJUST	C04	Laser power adjustment			<input type="radio"/>
Iop Write	C05	Iop data writing			<input type="radio"/>
Iop NV Save	C06	Writes current Iop value in read nonvolatile memory using microprocessor			<input type="radio"/>
EF MO ADJUST	C07	Traverse (MO) adjustment			<input type="radio"/>
EF CD ADJUST	C08	Traverse (CD) adjustment			<input type="radio"/>
FBIAS ADJUST	C09	Focus bias adjustment			<input type="radio"/>
AG Set (MO)	C10	Focus, tracking gain adjustment (MO)			<input type="radio"/>
AG Set (CD)	C11	Focus, tracking gain adjustment (CD)			<input type="radio"/>
TEMP CHECK	C12	Temperature compensation offset check		<input type="radio"/>	<input type="radio"/>
LDPWR CHECK	C13	Laser power check		<input type="radio"/>	<input type="radio"/>
EF MO CHECK	C14	Traverse (MO) check		<input type="radio"/>	<input type="radio"/>
EF CD CHECK	C15	Traverse (CD) check		<input type="radio"/>	<input type="radio"/>
FBIAS CHECK	C16	Focus bias check		<input type="radio"/>	<input type="radio"/>
ScurveCHECK	C17	S-curve check	×	<input type="radio"/>	
VERIFYMODE	C18	Nonvolatile memory check	×	<input type="radio"/>	
DETRK CHECK	C19	Detrack check	×	<input type="radio"/>	
0920 CHECK	C25	Most circumference check	×	<input type="radio"/>	
Iop Read	C26	Iop data display		<input type="radio"/>	<input type="radio"/>
Iop Compare	C27	Comparison with initial Iop value written in nonvolatile memory		<input type="radio"/>	<input type="radio"/>
ADJ CLEAR	C28	Initialization of nonvolatile memory for adjustment values			<input type="radio"/>
INFORMATION	C31	Display of microprocessor version, etc.		<input type="radio"/>	<input type="radio"/>
CPLAY1MODE	C34	Continuous playback mode		<input type="radio"/>	<input type="radio"/>
CREC 1MODE	C35	Continuous recording mode		<input type="radio"/>	<input type="radio"/>

- For details of each adjustment mode, refer to “5. Electrical Adjustments”.
For details of “Err Display”, refer to “Self-Diagnosis Function” on page 3.
- If a different mode has been selected by mistake, press the **MENU/NO** button to exit that mode.
- Modes with (X) in the Mark column are not used for servicing and therefore are not described in detail. If these modes are set accidentally, press the **MENU/NO** button to exit the mode immediately.

4-5-1. Operating the Continuous Playback Mode

1. Entering the continuous playback mode

- ① Set the disc in the unit. (Whichever recordable discs or discs for playback only are available.)
- ② Rotate the [◀◀ AMS ▶▶] knob and display "CPLAY1 MODE"(C34).
- ③ Press the [YES] button to change the display to "CPLAY1 MID".
- ④ When access completes, the display changes to "C = [] AD = []".

Note : The numbers "[]" displayed show you error rates and ADER.

2. Changing the parts to be played back

- ① Press the [YES] button during continuous playback to change the display as below.

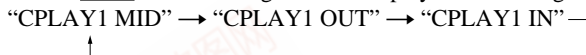

When pressed another time, the parts to be played back can be moved.

- ② When access completes, the display changes to "C = [] AD = []".

Note : The numbers "[]" displayed show you error rates and ADER.

3. Ending the continuous playback mode

- ① Press the [MENU/NO] button. The display will change to "CPLAY1 MODE"(C34).
- ② Press the [EJECT] button to remove the disc.

Note : The playback start addresses for IN, MID, and OUT are as follows.

- IN 40h cluster
- MID 300h cluster
- OUT 700h cluster

4-5-2. Operating the Continuous Recording Mode (Use only when performing self-recording/playback check.)

1. Entering the continuous recording mode

- ① Set a recordable disc in the unit.
- ② Rotate the [◀◀ AMS ▶▶] knob and display "CREC1 MODE" (C35).
- ③ Press the [YES] button to change the display to "CREC1 MID".
- ④ When access completes, the display changes to "CREC 1 ([])" and [REC] lights up.

Note : The numbers "[]" displayed shows you the recording position addresses.

2. Changing the parts to be recorded

- ① When the [YES] button is pressed during continuous recording, the display changes as below.



When pressed another time, the parts to be recorded can be changed. [REC] goes off.

- ② When access completes, the display changes to "CREC 1 ([])" and [REC] lights up.

Note : The numbers "[]" displayed shows you the recording position addresses.

3. Ending the continuous recording mode

- ① Press the [MENU/NO] button. The display changes to "CREC1 MODE" (C35) and [REC] goes off.
- ② Press the [EJECT] button to remove the disc.

Note 1 : The recording start addresses for IN, MID, and OUT are as follows.

- IN 40h cluster
- MID 300h cluster
- OUT 700h cluster

Note 2 : The [MENU/NO] button can be used to stop recording anytime.

Note 3 : Do not perform continuous recording for long periods of time above 5 minutes.

Note 4 : During continuous recording, be careful not to apply vibration.

4-6. FUNCTIONS OF OTHER BUTTONS

Function	Contents
▷	Sets continuous playback when pressed in the STOP state. When pressed during continuous playback, the tracking servo turns ON/OFF.
■	Stops continuous playback and continuous recording.
▶▶	The sled moves to the outer circumference only when this is pressed.
◀◀	The sled moves to the inner circumference only when this is pressed.
REC MODE	Switches between the pit and groove modes when pressed.
PLAY MODE	Switches the spindle servo mode (CLV S ↔ CLV A).
LEVEL/DISPLAY/CHAR	Switches the displayed contents each time the button is pressed.
⏏	Ejects the disc.
REPEAT	Exits the test mode.

4-7. TEST MODE DISPLAYS

Each time the **LEVEL/DISPLAY/CHAR** button is pressed, the display changes in the following order. When CPLAY and CREC are started, the display will forcibly be switched to the error rate display as the initial mode.

1. Mode display

Displays “TEMP ADJUST”, “CPLAY1MODE”, etc.

2. Error rate display

Displays the error rate in the following way.

C = □□□□ AD = □□

C = Indicates the C error.

AD = Indicates ADER.

3. Address display

The address is displayed as follows. (MO:recordable disc, CD:playback only disc)

If the **REC MODE** button is pressed, the display switches from groove to pit or vice versa.

h = □□□□ s = □□□□ (MO pit and CD)

h = □□□□ a = □□□□ (MO groove)

h = Indicates the header address.

s = Indicates the SUBQ address.

a = Indicates the ADIP address.

Note: “-” is displayed when the address cannot be read.

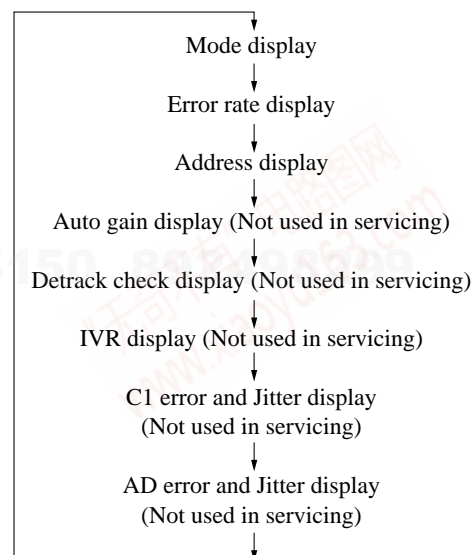

4-8. MEANINGS OF OTHER DISPLAYS

Display	Contents	
	When Lit	When Off
▷	Servo ON	Servo OFF
	Tracking servo OFF	Tracking servo ON
REC	Recording mode ON	Recording mode OFF
SYNC	CLV low speed mode	CLV normal mode
L.SYNC	ABCD adjustment completed	
OVER	Tracking offset cancel ON	Tracking offset cancel OFF
B/I	Tracking auto gain OK	
A-/REP	Focus auto gain OK	
REC MODE	Pit	Groove
DISC/LP2	High reflection	Low reflection
SLEEP/SHUF	CLV S	CLV A
MONO	CLV LOCK	CLV UNLOCK

4-9. AUTOMATIC SELF-DIAGNOSIS FUNCTION

This test mode performs CREC and CPLAY automatically for mainly checking the characteristics of the optical pick-up.

To perform this test mode, the laser power must first be checked.

Perform AUTO CHECK after the laser power check and Iop check.

Procedure

1. Press the **YES** button. If “LDPWR ミチェック” is displayed, it means that the laser power check has not been performed. In this case, perform the laser power check and Iop compare, and then repeat from step 1.
2. If a disc is in the mechanical deck, it will be ejected forcibly.
“DISC IN” will be displayed in this case. Load a test disc (MDW-74/GA-1) which can be recorded.
3. If a disk is loaded at step 2, the check will start automatically.
4. When “XX CHECK” is displayed, the item corresponding to XX will be performed.
When “06 CHECK” completes, the disc loaded at step 2 will be ejected. “DISC IN” will be displayed. Load the check disc (MD) TDYS-1.
5. When the disc is loaded in step 4, the check will automatically be resumed from “07 CHECK”.
6. After completing to test item 12, check OK or NG will be displayed. If all items are OK, “CHECK ALL OK” will be displayed. If any item is NG, it will be displayed as “NG:xxxx”.

When “CHECK ALL OK” is displayed, it means that the optical pick-up is normal. Check the operations of the other spindle motor, thread motor, etc.

When displayed as “NG:xxxx”, it means that the optical pick-up is faulty. In this case, replace the optical pick-up.

4-10. INFORMATION

Display the software version.

Procedure

1. If displayed as “INFORMATION”, press the **YES** button.
2. The software version will be displayed.
3. Press the **MENU/NO** button to end this mode.

4-11. WHEN MEMORY NG IS DISPLAYED

If the nonvolatile memory data is abnormal, “E001”/“MEMORY NG” will be displayed so that the MD deck does not continue operations.

In this case, set the test mode promptly and perform the following procedure.

Procedure

1. Set the test mode. (Refer to 4-2.)
2. Normally a message for selecting the test mode will be displayed. However if the nonvolatile memory is abnormal, the following will be displayed. “INIT EEP?”
3. Press the **STOP** button and **EJECT** button together.
4. Rotate the **AMS** knob and select MDM-7S1A.
5. Press the **AMS** knob. If the nonvolatile memory is successfully overwritten, the normal test mode will be set and a message to select the test mode will be displayed.

Note: When this setting is doing, readjustment is necessary.
(Adjustment it same as IC195 exchanged)

SECTION 5 ELECTRICAL ADJUSTMENTS

Note : 260B: KMS-260B
260E: KMS-260E

5-1. PARTS REPLACEMENT AND ADJUSTMENT

If malfunctions caused by Optical pick-up such as sound skipping are suspected, follow the following check.

Check before replacement

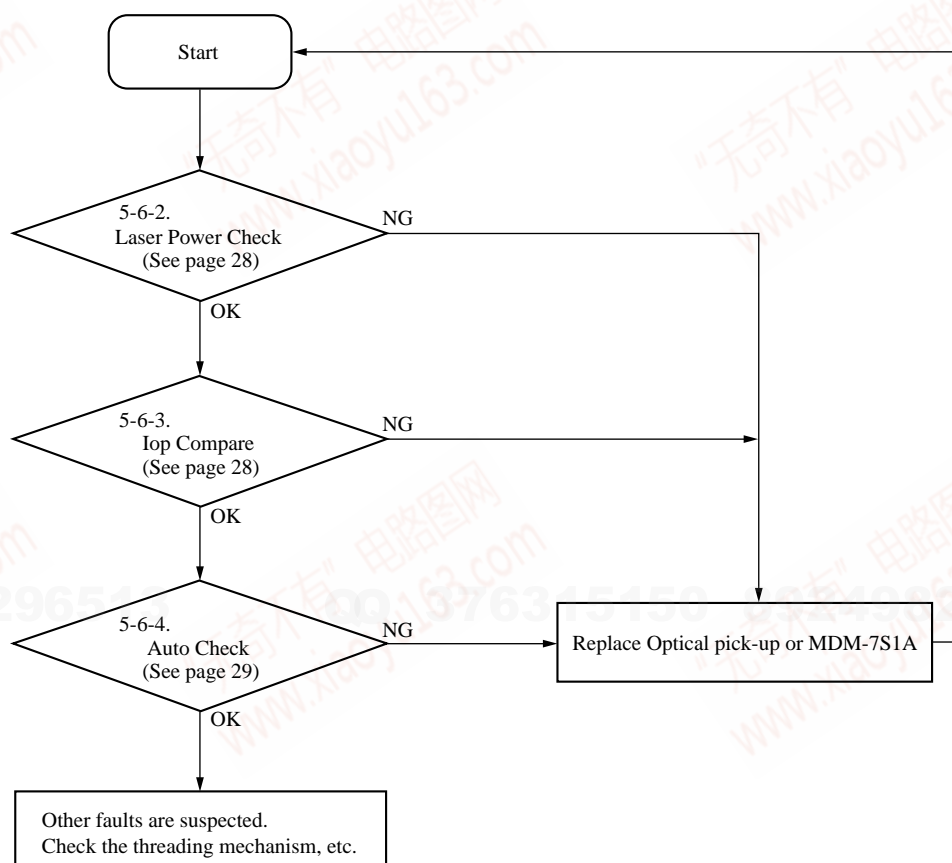

Adjustment flow

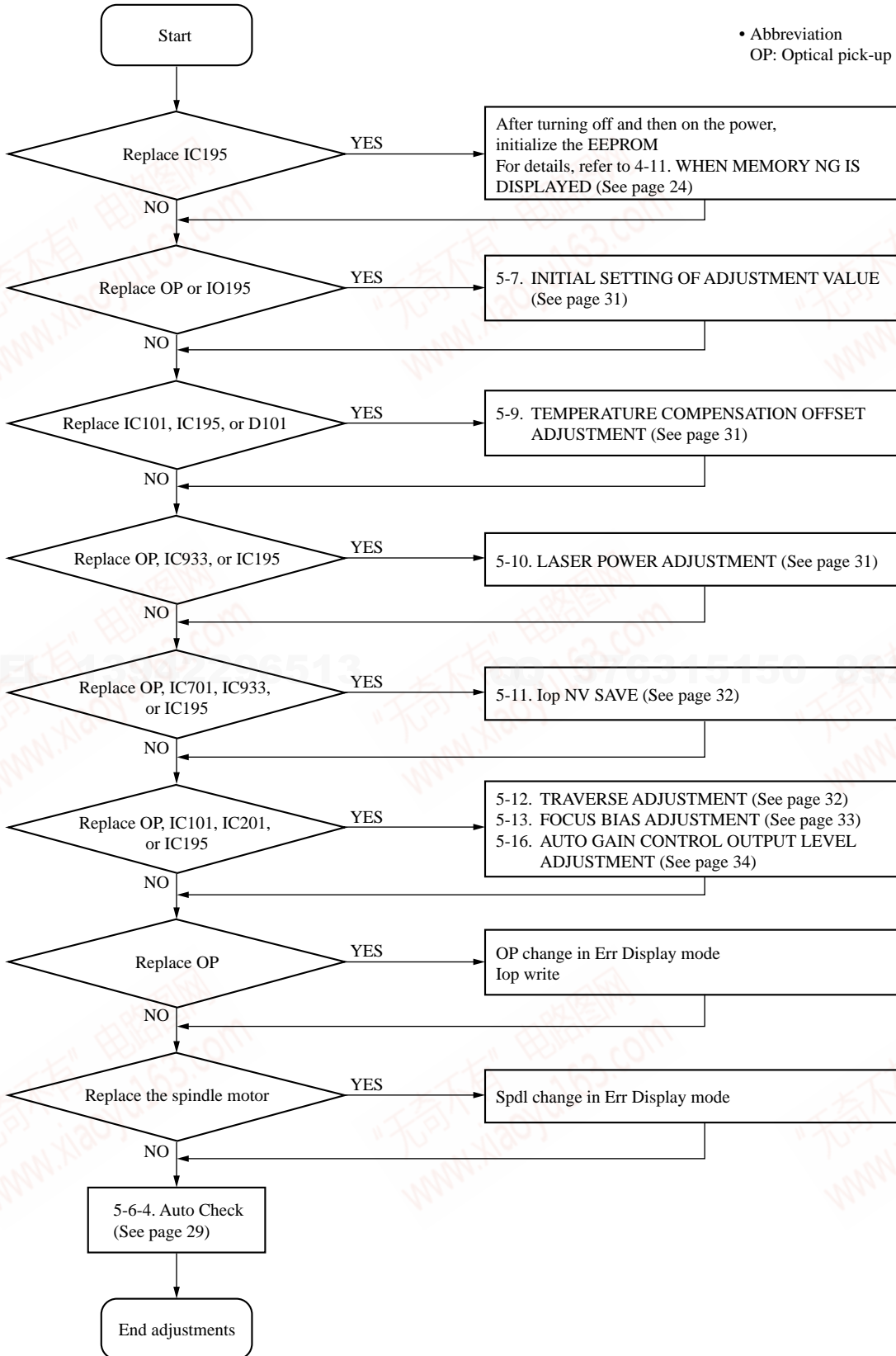

892498299

5-2. PRECAUTIONS FOR CHECKING LASER DIODE EMISSION

To check the emission of the laser diode during adjustments, never view directly from the top as this may lose your eye-sight.

5-3. PRECAUTIONS FOR USE OF OPTICAL PICK-UP (KMS-260B/260E)

As the laser diode in the optical pick-up is easily damaged by static electricity, solder the laser tap of the flexible board when using it. Before disconnecting the connector, desolder first. Before connecting the connector, be careful not to remove the solder. Also take adequate measures to prevent damage by static electricity. Handle the flexible board with care as it breaks easily.

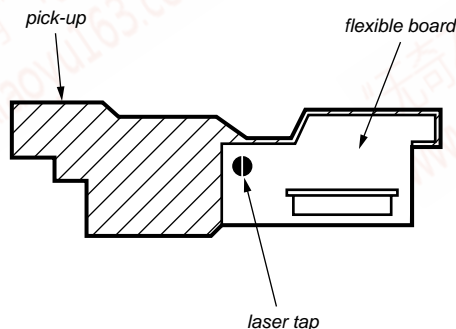

Optical pick-up flexible board

5-4. PRECAUTIONS FOR ADJUSTMENTS

- 1) When replacing the following parts, perform the adjustments and checks with ○ in the order shown in the following table.
- 2) Set the test mode when performing adjustments.
After completing the adjustments, exit the test mode.
Perform the adjustments and checks in "group S" of the test mode.
- 3) Perform the adjustments to be needed in the order shown.
- 4) Use the following tools and measuring devices.
 - Check Disc (MD) TDYS-1 (Parts No. 4-963-646-01)
 - Test Disk (MDW-74/GA-1) (Parts No. 4-229-747-01)
 - Laser power meter LPM-8001 (Parts No. J-2501-046-A)
 or
 - MD Laser power meter 8010S (Parts No. J-2501-145-A)
 - Oscilloscope (Measure after performing CAL of prove.)
 - Digital voltmeter
 - Thermometer
 - Jig for checking BD board waveform (Parts No. : J-2501-196-A)
- 5) When observing several signals on the oscilloscope, etc., make sure that VC and ground do not connect inside the oscilloscope.
(VC and ground will become short-circuited.)
- 6) Using the above jig enables the waveform to be checked without the need to solder.
(Refer to Servicing Note on page 6.)
- 7) As the disc used will affect the adjustment results, make sure that no dusts nor fingerprints are attached to it.

Adjustment	Parts to be replaced						
	Optical Pick-up	IC101	IC701	IC201	IC933	IC195	D101
5-7. Initial setting of adjustment values	○	×	×	×	×	○	×
5-8. Recording of Iop information	○	×	×	×	×	○	×
5-9. TEMP ADJUST	×	○	×	×	×	○	○
5-10. Laser power adjustment	○	×	×	×	○	○	×
5-11. Iop NV Save	○	×	○	×	○	○	×
5-12. Traverse adjustment	○	○	×	○	×	○	×
5-13. Focus bias adjustment	○	○	×	○	×	○	×
5-16. Auto gain adjustment	○	○	×	○	×	○	×
5-6-4. AUTO CHECK	○	○	×	○	○	○	×

MDS-JE480

5-5. USING THE CONTINUOUSLY RECORDED DISC

* This disc is used in focus bias adjustment and error rate check.
The following describes how to create a continuous recording disc.

1. Insert a disc (blank disc) commercially available.
2. Rotate the [◀◀ AMS ▶▶] knob and display "CREC1 MODE".
3. Press the [YES] button again to display "CREC1 MID".
4. Press the [LEVEL/DISPLAY/CHAR] button.
Display "CREC (0300)" and start to recording.
5. Complete recording within 5 minutes.
6. Press the [MENU/NO] button and stop recording .
7. Press the [EJECT] button and remove the disc.

The above has been how to create a continuous recorded data for the focus bias adjustment and error rate check.

Note :

- Be careful not to apply vibration during continuous recording.

5-6. CHECKS PRIOR TO REPAIRS

These checks are performed before replacing parts according to "approximate specifications" to determine the faulty locations. For details, refer to "Checks Prior to Parts Replacement and Adjustments" (See page 9).

5-6-1. Temperature Compensation Offset Check

When performing adjustments, set the internal temperature and room temperature to 22 to 28°C.

Checks cannot be performed properly if performed after some time from power ON due to the rise in the temperature of the IC and diode, etc. So, perform the checks again after waiting some time.

Checking Procedure:

1. Rotate the [◀◀ AMS ▶▶] knob to display "TEMP CHECK". (C12)
2. Press the [YES] button.
3. "T=@@ (##) [OK]" should be displayed. If "T=@@ (##) [NG]" is displayed, it means that the results are bad.
(@@ indicates the current value set, and ## indicates the value written in the non-volatile memory.)

5-6-2. Laser Power Check

Before checking, check the Iop value of the optical pick-up.
(Refer to 5-8. Recording and Displaying Iop Information.)

Connection :

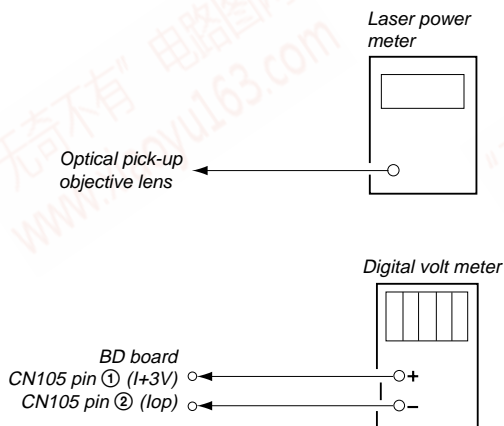

Checking Procedure:

1. Set the laser power meter on the objective lens of the optical pick-up. (When it cannot be set properly, press the [◀] button or [▶] button to move the optical pick-up.)
Connect the digital volt meter to CN105 pin ① (+3V) and CN105 pin ② (Iop).
2. Then, rotate the [◀◀ AMS ▶▶] knob and display "LDPWR CHECK".
3. Press the [YES] button once and display "L 0.93 mW \$ []".
Check that the reading of the laser power meter become the specified value.
4. Press the [YES] button once more and display " L 7.25 mW \$ []".
Check that the reading the laser power meter and digital volt meter satisfy the specified value.

Specified Value :

Laser power meter reading : L 0.93mW: 0.85-0.91mW (260B)
0.90-0.96mW (260E)
L 7.25mW: 6.80-7.20mW (260B)
7.00-7.50mW (260E)

Digital voltmeter reading : Optical pick-up displayed value ± 10%

(Optical pick-up label)

KMS260B
20101
H0576

(For details of the method for checking this value, refer to "5-8. Recording and Displaying Iop Information".)

Iop = 57.6 mA in this case

Iop (mA) = Digital voltmeter reading (mV)/1 (Ω)

5. Press the [MENU/NO] button and display "LDPWR CHECK" and stop the laser emission.
(The [MENU/NO] button is effective at all times to stop the laser emission.)

Note 1: After step 4, each time the [YES] button is pressed, the display will be switched between "L 0.73 mW \$ []", "L 6.40 mW \$ []", and "L Wp ホセ イ \$ []". Nothing needs to be performed here.

5-6-3. Iop Compare

The current Iop value at laser power 7 mw output and reference Iop value (set at shipment) written in the nonvolatile memory are compared, and the rate of increase/decrease will be displayed in percentage.

Note: Perform this function with the optical pick-up set at room temperature.

Procedure

1. Rotate the [◀◀ AMS ▶▶] knob to display "Iop Compare".
2. Press the [YES] button and start measurements.
3. When measurements complete, the display changes to Iop [STOP] → Iop [7.0mW] → "±xx%yy".
xx is the percentage of increase/decrease, and OK or NG is displayed at yy to indicate whether the percentage of increase/decrease is within the allowable range.
4. Press the [MENU/NO] button to end.

5-6-4. Auto Check

This test mode performs CREC and CPLAY automatically for mainly checking the characteristics of the optical pick-up. To perform this test mode, the laser power must first be checked. Perform Auto Check after the laser power check and Iop compare.

Procedure

1. Press the **YES** button. If “LDPWR ミチェック” is displayed, it means that the laser power check has not been performed. In this case, perform the laser power check and Iop compare, and then repeat from step 1.
2. If a disc is in the mechanical deck, it will be ejected forcibly. “DISC IN” will be displayed in this case. Load a test disc (MDW-74/GA-1) which can be recorded.
3. If a disc is loaded at step 2, the check will start automatically.
4. When “XX CHECK” is displayed, the item corresponding to XX will be performed.
When “06 CHECK” completes, the disc loaded at step 2 will be ejected. “DISC IN” will be displayed. Load the check disc (MD) TDYS-1.
5. When the disc is loaded, the check will automatically be resumed from “07 CHECK”.
6. After completing to test item 12, check OK or NG will be displayed. If all items are OK, “CHECK ALL OK” will be displayed. If any item is NG, it will be displayed as “NG:xxxx”.

When “CHECK ALL OK” is displayed, it means that the optical pick-up is normal. Check the operations of the other spindle motor, thread motor, etc.

When displayed as “NG:xxxx”, it means that the optical pick-up is faulty. In this case, replace the optical pick-up.

5-6-5. Other Checks

All the following checks are performed by the Auto Check mode. They therefore need not be performed in normal operation.

1. Load a continuously recorded test disc (MDW-74/GA-1). (Refer to “5-5. Using the Continuously Recorded Disc”.)

5-6-6. Traverse Check

Connection :

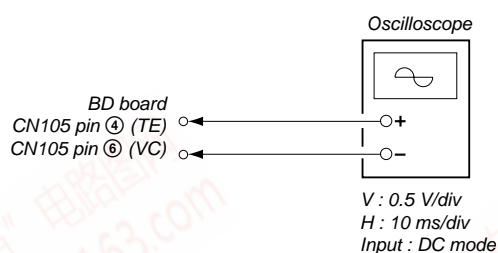

Checking Procedure:

1. Connect an oscilloscope to CN105 pin ④ (TE) and CN105 pin ⑥ (VC) of the BD board.
2. Load a test disc (MDW-74/GA-1). (Refer to Note 1.)
3. Press the **▶▶** button and move the optical pick-up outside the pit.
4. Rotate the **◀◀ AMS ▶▶** knob and display “EF MO CHECK”.
5. Press the **YES** button and display “EFB = MO-R”.
(Laser power READ power/Focus servo ON/tracking servo OFF/spindle (S) servo ON)

6. Observe the waveform of the oscilloscope, and check that the specified value is satisfied. Do not rotate the **AMS** knob.
(Read power traverse checking)

(Traverse Waveform)

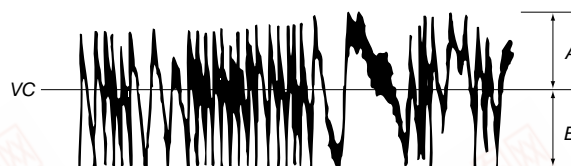

Specified value : Below 10% offset value

$$\text{Offset value (\%)} = \frac{|A - B|}{2(A + B)} \times 100$$

7. Press the **YES** button and display “EFB = MO-W”.
8. Observe the waveform of the oscilloscope, and check that the specified value is satisfied. Do not rotate the **◀◀ AMS ▶▶** knob.

(Write power traverse checking)

(Traverse Waveform)

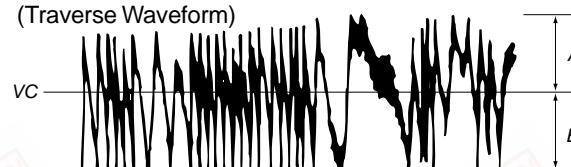

Specified value : Below 10% offset value

$$\text{Offset value (\%)} = \frac{|A - B|}{2(A + B)} \times 100$$

9. Press the **YES** button display “EFB = MO-P”.
Then, the optical pick-up moves to the pit area automatically and servo is imposed.
10. Observe the waveform of the oscilloscope, and check that the specified value is satisfied. Do not rotate the **◀◀ AMS ▶▶** knob.

(Traverse Waveform)

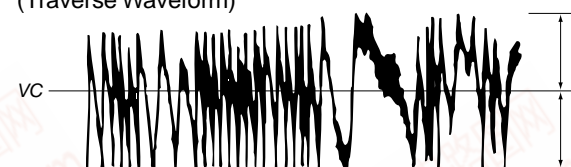

Specified value : Below 10% offset value

$$\text{Offset value (\%)} = \frac{|A - B|}{2(A + B)} \times 100$$

11. Press the **YES** button display “EF MO CHECK”.
The disc stops rotating automatically.
12. Press the **EJECT** button and remove the disc.
13. Load the check disc (MD) TDYS-1.
14. Rotate the **◀◀ AMS ▶▶** knob and display “EF CD CHECK” (C04).
15. Press the **YES** button and display “EFB = CD”. Servo is imposed automatically.

16. Observe the waveform of the oscilloscope, and check that the specified value is satisfied. Do not rotate the $\llbracket \llcorner \text{AMS} \lrcorner \rrbracket$ knob.

(Traverse Waveform)

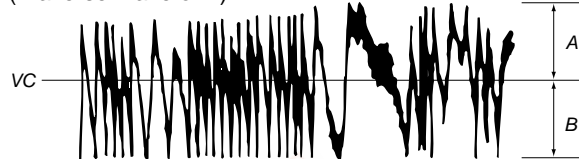

Specified value : Below 10% offset value

$$\text{Offset value (\%)} = \frac{|A - B|}{2(A + B)} \times 100$$

17. Press the $\llbracket \text{YES} \rrbracket$ button and display “EF CD CHECK”.
18. Press the $\llbracket \text{EJECT} \rrbracket$ button and remove the check disc (MD) TDYS-1.

Note 1 : MO reading data will be erased during if a recorded disc is used in this adjustment.

Note 2 : If the traverse waveform is not clear, connect the oscilloscope as shown in the following figure so that it can be seen more clearly.

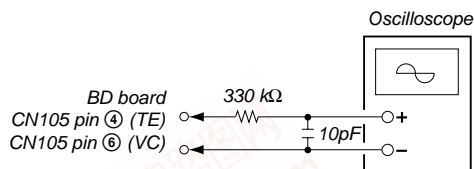

5-6-7. Focus Bias Check

Change the focus bias and check the focus tolerance amount.

Checking Procedure :

1. Load a continuously recorded test disc (MDW-74/GA-1). (Refer to “5-5. Using the Continuously Recorded Disc”.)
2. Rotate the $\llbracket \llcorner \text{AMS} \lrcorner \rrbracket$ knob and display “CPLAY1 MODE”.
3. Press the $\llbracket \text{YES} \rrbracket$ button and display “CPLAY1 MID”.
4. The display change to “C = $\square\square\square\square$ AD = $\square\square$ ”.
5. Press the $\llbracket \text{MENU/NO} \rrbracket$ button and display “CPLAY1 MODE”.
6. Rotate the $\llbracket \llcorner \text{AMS} \lrcorner \rrbracket$ knob and display “FBIAS CHECK”.
7. Press the $\llbracket \text{YES} \rrbracket$ button and display “ $\square\square\square\square/\square\square$ c = $\square\square$ ”.

The first four digits indicate the C error rate, the two digits after [/] indicate ADER, and the 2 digits after [c =] indicate the focus bias value.

- Check that the C error is below 50 and ADER is below 2.
8. Press the $\llbracket \text{YES} \rrbracket$ button and display “ $\square\square\square\square/\square\square$ b = $\square\square$ ”.
 - Check that the C error is below 100 and ADER is below 2.
 9. Press the $\llbracket \text{YES} \rrbracket$ button and display “ $\square\square\square\square/\square\square$ a = $\square\square$ ”.
 - Check that the C error is below 100 and ADER is below 2.
 10. Press the $\llbracket \text{MENU/NO} \rrbracket$ button, next press the $\llbracket \text{EJECT} \rrbracket$ button, and remove the test disc.

5-6-8. C PLAY Check

MO Error Rate Check

Checking Procedure :

1. Load a continuously recorded test disc (MDW-74/GA-1). (Refer to “5-5. Using the Continuously Recorded Disc”.)
2. Rotate the $\llbracket \llcorner \text{AMS} \lrcorner \rrbracket$ knob and display “CPLAY1 MODE”.
3. Press the $\llbracket \text{YES} \rrbracket$ button and display “CPLAY1 MID”.
4. The display changes to “C = $\square\square\square\square$ AD = $\square\square$ ”.
5. If the C error rate is below 50, check that ADER is 2.
6. Press the $\llbracket \text{MENU/NO} \rrbracket$ button, stop playback, press the $\llbracket \text{EJECT} \rrbracket$ button, and test disc.

CD Error Rate Check

Checking Procedure :

1. Load a check disc (MD) TDYS-1.
2. Rotate the $\llbracket \llcorner \text{AMS} \lrcorner \rrbracket$ knob and display “CPLAY1 MODE”.
3. Press the $\llbracket \text{YES} \rrbracket$ button twice and display “CPLAY1 MID”.
4. The display changes to “C = $\square\square\square\square$ AD = $\square\square$ ”.
5. Check that the C error rate is below 50.
6. Press the $\llbracket \text{MENU/NO} \rrbracket$ button, stop playback, press the $\llbracket \text{EJECT} \rrbracket$ button, and the test disc.

5-6-9. Self-Recording/playback Check

Prepare a continuous recording disc using the unit to be repaired and check the error rate.

Checking Procedure :

1. Insert a recordable test disc (MDW-74/GA-1) into the unit.
2. Rotate the $\llbracket \llcorner \text{AMS} \lrcorner \rrbracket$ knob to display “CREC1 MODE”.
3. Press the $\llbracket \text{YES} \rrbracket$ button to display the “CREC1 MID”.
4. When recording starts, “**REC**” is displayed, this becomes “CREC 1 (@@@@)” (@@@@ is the address), and recording starts.
5. About 1 minute later, press the $\llbracket \text{MENU/NO} \rrbracket$ button to stop continuous recording.
6. Rotate the $\llbracket \llcorner \text{AMS} \lrcorner \rrbracket$ knob to display “C PLAY1 MODE”.
7. Press the $\llbracket \text{YES} \rrbracket$ button to display “C PLAY1 MID”.
8. “C = $\square\square\square\square$ AD = $\square\square$ ” will be displayed.
9. Check that the C error becomes below 50 and the AD error below 2.
10. Press the $\llbracket \text{MENU/NO} \rrbracket$ button to stop playback, and press the $\llbracket \text{EJECT} \rrbracket$ button and remove the disc.

5-7. INITIAL SETTING OF ADJUSTMENT VALUE

Note:

Mode which sets the adjustment results recorded in the non-volatile memory to the initial setting value. However the results of the temperature compensation offset adjustment will not change to the initial setting value.

If initial setting is performed, perform all adjustments again excluding the temperature compensation offset adjustment.

For details of the initial setting, refer to “5-4. Precautions on Adjustments” and execute the initial setting before the adjustment as required.

Setting Procedure :

1. Rotate the [◀◀ AMS ▶▶] knob to display “ADJ CLEAR”.
2. Press the [YES] button. “Complete!” will be displayed momentarily and initial setting will be executed, after which “ADJ CLEAR” will be displayed.

5-8. RECORDING AND DISPLAYING THE Iop INFORMATION

The Iop data can be recorded in the non-volatile memory. The Iop value on the label of the optical pick-up and the Iop value after the adjustment will be recorded. Recording these data eliminates the need to read the label on the optical pick-up.

Recording Procedure :

1. While pressing the [◀◀ AMS ▶▶] knob and [■] button, connect the power plug to the outlet, and release the [◀◀ AMS ▶▶] knob and [■] button.
2. Rotate the [◀◀ AMS ▶▶] knob to display “[Service]”, and press the [YES] button.
3. Rotate the [◀◀ AMS ▶▶] knob to display “Iop.Write”, and press the [YES] button.
4. The display becomes Ref=@@.@ (@ is an arbitrary number) and the numbers which can be changed will blink.
5. Input the Iop value written on the optical pick-up.
To select the number : Rotate the [◀◀ AMS ▶▶] knob.
To select the digit : Press the [◀◀ AMS ▶▶] knob
6. When the [YES] button is pressed, the display becomes “Measu=@@.@” (@ is an arbitrary number).
7. As the adjustment results are recorded for the 6 value. Leave it as it is and press the [YES] button.
8. “Complete!” will be displayed momentarily. The value will be recorded in the non-volatile memory and the display will become “Iop Write”.

Display Procedure :

1. Rotate the [◀◀ AMS ▶▶] knob to display “Iop.Read”.
2. “@@.@/##.#” is displayed and the recorded contents are displayed.
@@.@ indicates the Iop value labeled on the pick-up.
##.# indicates the Iop value after adjustment
3. To end, press the [◀◀ AMS ▶▶] button or [MENU/NO] button to display “Iop Read”.

5-9. TEMPERATURE COMPENSATION OFFSET ADJUSTMENT

Save the temperature data at that time in the non-volatile memory as 25 °C reference data.

Note :

1. Usually, do not perform this adjustment.
2. Perform this adjustment in an ambient temperature of 22 °C to 28 °C. Perform it immediately after the power is turned on when the internal temperature of the unit is the same as the ambient temperature of 22 °C to 28 °C.
3. When D101 has been replaced, perform this adjustment after the temperature of this part has become the ambient temperature.

Adjusting Procedure :

1. Rotate the [◀◀ AMS ▶▶] knob and display “TEMPADJUST”.
2. Press the [YES] button and select the “TEMP ADJUST” mode.
3. “TEMP = [] [OK]” and the current temperature data will be displayed.
4. To save the data, press the [YES] button.
When not saving the data, press the [MENU/NO] button.
5. When the [YES] button is pressed, “TEMP = [] SAVE” will be displayed and turned back to “TEMP ADJUST” display then. When the [MENU/NO] button is pressed, “TEMP ADJUST” will be displayed immediately.

Specified Value :

The “TEMP = []” should be within “E0 - EF”, “F0 - FF”, “00 - 0F”, “10 - 1F” and “20 - 2F”.

5-10. LASER POWER ADJUSTMENT

Check the Iop value of the optical pick-up before adjustments. (Refer to 5-8. Recording and Displaying Iop Information.)

Connection :

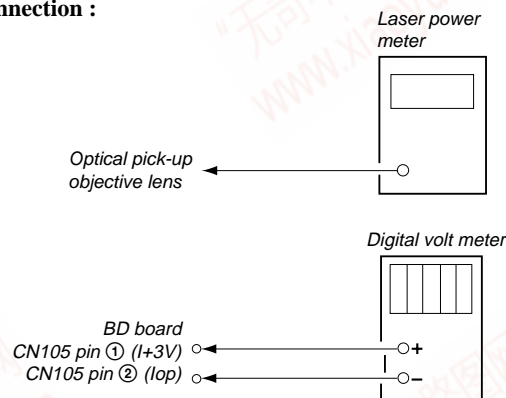

Adjusting Procedure :

1. Set the laser power meter on the objective lens of the optical pick-up. (When it cannot be set properly, press the [◀] button or [▶] button to move the optical pick-up.)
Connect the digital volt meter to CN105 pin ① (I+3V) and CN105 pin ② (Iop).
2. Rotate the [◀◀ AMS ▶▶] knob and display “LDPWR ADJUST”.
(Laser power : For adjustment)
3. Press the [YES] button once and display “L 0.93 mW \$ []”.
4. Rotate the [◀◀ AMS ▶▶] knob so that the reading of the laser power meter becomes the specified value. Press the [YES] button after setting the range knob of the laser power meter, and save the adjustment results. (“L SAVE \$ []” will be displayed for a moment.)
5. Then “L 7.25 mW \$ []” will be displayed.
6. Rotate the [◀◀ AMS ▶▶] knob so that the reading of the laser power meter becomes the specified value, press the [YES] button and save it.

Note : Do not perform the emission with 7.25 mW more than 15 seconds continuously.

MDS-JE480

- Then, rotate the **◀◀ AMS ▶▶** knob and display "LDPWR CHECK".
- Press the **YES** button once and display "L 0.93 mW \$ []". Check that the reading of the laser power meter become the specified value.
- Press the **YES** button once more and display "L 7.25 mW \$ []". Check that the reading the laser power meter and digital volt meter satisfy the specified value.
Note down the digital voltmeter reading value.

Specified Value :

Laser power meter reading : L 0.93mW : 0.85-0.91mW (260B)
 0.90-0.96mW (260E)
 L 7.25mW : 6.90-7.10mW (260B)
 7.20-7.30mW (260E)

Digital voltmeter reading : Optical pick-up displayed value ± 10%

(Optical pick-up label)

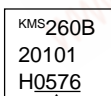

(For details of the method for checking this value, refer to "5-8. Recording and Displaying Iop Information".)

Iop = 57.6 mA in this case
 $Iop (mA) = Digital\ voltmeter\ reading (mV) / 1 (\Omega)$

- Press the **MENU/NO** button and display "LDPWR CHECK" and stop the laser emission.
(The **MENU/NO** button is effective at all times to stop the laser emission.)
- Rotate the **◀◀ AMS ▶▶** knob to display "Iop.Write".
- Press the **YES** button. When the display becomes Ref = @ @ @ .@ (@ is an arbitrary number), press the **YES** button to display "Measu=@ @ @ .@" (@ is an arbitrary number).
- The numbers which can be changed will blink. Input the Iop value noted down at step 9.
To select the number : Rotate the **◀◀ AMS ▶▶** knob.
To select the digit : Press the **◀◀ AMS ▶▶** knob
- When the **YES** button is pressed, "Complete!" will be displayed momentarily. The value will be recorded in the non-volatile memory and the display will become "Iop Write".

Note 1: After step 4, each time the **YES** button is pressed, the display will be switched between "L 0.73 mW \$ []", "L 6.40 mW \$ []", and "L Wp ホセ イ \$ []". Nothing needs to be performed here.

5-11. Iop NV SAVE

Write the reference values in the nonvolatile memory to perform "Iop compare". As this involves rewriting the reference values, do not perform this procedure except when adjusting the laser power during replacement of the OP and when replacing the IC701. Otherwise the OP check may deteriorate.

Note: Perform this function with the optical pick-up set at room temperature.

Procedure

- Rotate the **◀◀ AMS ▶▶** knob to display "Iop NV Save" (C06).
- Press the **YES** button and display "Iop [stop]".
- After the display changes to "Iop =xxsave?", press the **YES** button.
- After "Complete!" is displayed momentarily, the display changes to "Iop 7.0 mW".
- After the display changes to "Iop=yysave?", press the **YES** button.
- When "Complete!" is displayed, it means that Iop NV saving has been completed.

5-12. TRAVERSE ADJUSTMENT

Connection :

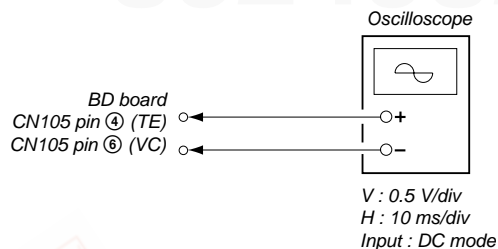

Adjusting Procedure :

- Connect an oscilloscope to CN105 pin 4 (TE) and CN105 pin 6 (VC) of the BD board.
- Load a test disc (MDW-74/GA-1). (Refer to Note 1.)
- Press the **▶▶** button and move the optical pick-up outside the pit.
- Rotate the **◀◀ AMS ▶▶** knob and display "EF MO ADJUST".
- Press the **YES** button and display "EFB = [] MO-R".
(Laser power READ power/Focus servo ON/tracking servo OFF/spindle (S) servo ON)
- Rotate the **◀◀ AMS ▶▶** knob so that the waveform of the oscilloscope becomes the specified value.
(When the **◀◀ AMS ▶▶** knob is rotated, the [] of "EFB=[]" changes and the waveform changes.) In this adjustment, waveform varies at intervals of approx. 2%. Adjust the waveform so that the specified value is satisfied as much as possible. (Read power traverse adjustment)

(Traverse Waveform)

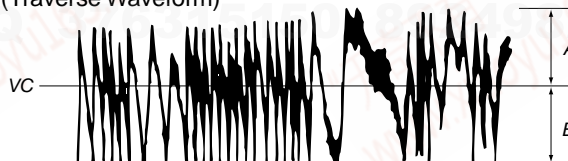

Specification A = B

- Press the **YES** button and save the result of adjustment to the non-volatile memory ("EFB = [] SAVE" will be displayed for a moment. Then "EFB = [] MO-W" will be displayed).
- Rotate the **◀◀ AMS ▶▶** knob so that the waveform of the oscilloscope becomes the specified value.
(When the **◀◀ AMS ▶▶** knob is rotated, the [] of "EFB=[] MO-W" changes and the waveform changes.) In this adjustment, waveform varies at intervals of approx. 2%. Adjust the waveform so that the specified value is satisfied as much as possible. (Write power traverse adjustment)

(Traverse Waveform)

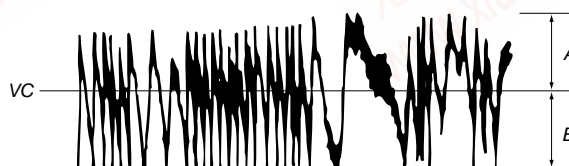

Specification A = B

- Press the **YES** button, and save the adjustment results in the non-volatile memory. ("EFB = [] SAVE" will be displayed for a moment.)
- "EFB = [] MO-P". will be displayed.
The optical pick-up moves to the pit area automatically and servo is imposed.

- Rotate the \llcorner AMS \lrcorner knob until the waveform of the oscilloscope moves closer to the specified value.
In this adjustment, waveform varies at intervals of approx. 2%.
Adjust the waveform so that the specified value is satisfied as much as possible.

(Traverse Waveform)

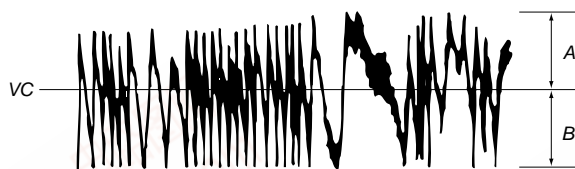

Specification $A = B$

- Press the YES button, and save the adjustment results in the non-volatile memory. ("EFB = $\square\square$ SAVE" will be displayed for a moment.)
Next "EF MO ADJUS" is displayed. The disc stops rotating automatically.
- Press the EJECT button and remove the disc.
- Load the check disc (MD) TDYS-1.
- Rotate \llcorner AMS \lrcorner knob and display "EF CD ADJUST".
- Press the YES button and display "EFB = $\square\square$ CD". Servo is imposed automatically.
- Rotate the \llcorner AMS \lrcorner knob so that the waveform of the oscilloscope moves closer to the specified value.
In this adjustment, waveform varies at intervals of approx. 2%.
Adjust the waveform so that the specified value is satisfied as much as possible.

(Traverse Waveform)

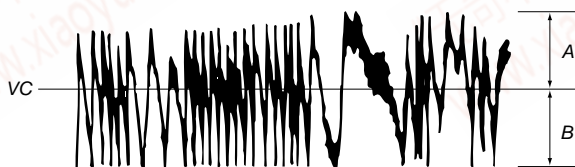

Specification $A = B$

- Press the YES button, display "EFB = $\square\square$ SAVE" for a moment and save the adjustment results in the non-volatile memory. Next "EF CD ADJUST" will be displayed.
- Press the EJECT button and remove the check disc (MD) TDYS-1.

Note 1 : MO reading data will be erased during if a recorded disc is used in this adjustment.

Note 2 : If the traverse waveform is not clear, connect the oscilloscope as shown in the following figure so that it can be seen more clearly.

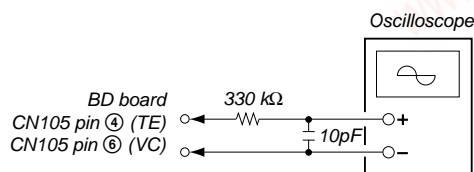

5-13. FOCUS BIAS ADJUSTMENT

Adjusting Procedure :

- Load a test disk (MDW-74/GA-1).
- Rotate the \llcorner AMS \lrcorner knob and display "CPLAY1 MODE".
- Press the YES button and display "CPLAY1 MID".
- The display change to "C = $\square\square\square\square$ AD = $\square\square$ ".
- Press the MENU/NO button and display "CPLAY1 MODE".
- Rotate the \llcorner AMS \lrcorner knob and display "FBIAS ADJUST".
- Press the YES button and display " $\square\square\square\square/\square\square$ a = $\square\square$ ".
The first four digits indicate the C error rate, the two digits after [/] indicate ADER, and the 2 digits after [a =] indicate the focus bias value.
- Rotate the \llcorner AMS \lrcorner knob in the clockwise direction and find the focus bias value at which the C error rate becomes 220 (Refer to Note 2).
- Press the YES button and display " $\square\square\square\square/\square\square$ b = $\square\square$ ".
- Rotate the \llcorner AMS \lrcorner knob in the counterclockwise direction and find the focus bias value at which the C error rate becomes 220.
- Press the YES button and display " $\square\square\square\square/\square\square$ c = $\square\square$ ".
- Check that the C error rate is below 50 and ADER is 2. Then press the YES button.
- If the " $\square\square$ " in " $\square\square - \square\square - \square\square$ " is above 20, press the YES button.
If below 20, press the MENU/NO button and repeat the adjustment from step 2.
- Press the EJECT button to remove the test disc.

Note 1 : The relation between the C error and focus bias is as shown in the following figure. Find points a and b in the following figure using the above adjustment. The focal point position C is automatically calculated from points a and b.

Note 2 : As the C error rate changes, perform the adjustment using the average value.

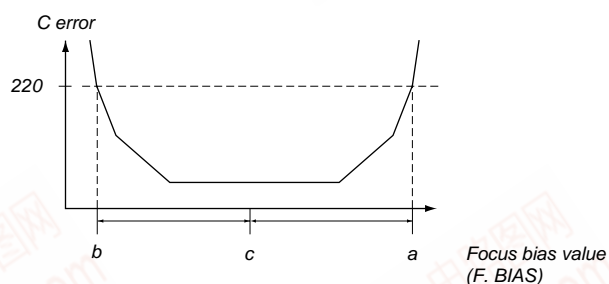

5-14. ERROR RATE CHECK**5-14-1. CD Error Rate Check****Checking Procedure :**

1. Load a check disc (MD) TDYS-1.
2. Rotate the [◀◀ AMS ▶▶] knob and display "CPLAY1 MODE".
3. Press the [YES] button twice and display "CPLAY1 MID".
4. The display changes to "C = [] AD = []".
5. Check that the C error rate is below 50.
6. Press the [MENU/NO] button, stop playback, press the [EJECT] button, and remove the test disc.

5-14-2. MO Error Rate Check**Checking Procedure :**

1. Load a continuously recorded test disc (MDW-74/GA-1). (Refer to "5-5. Using the Continuously Recorded Disc".)
2. Rotate the [◀◀ AMS ▶▶] knob and display "CPLAY1 MODE".
3. Press the [YES] button and display "CPLAY1 MID".
4. The display changes to "C = [] AD = []".
5. If the C error rate is below 50, check that ADER is 2.
6. Press the [MENU/NO] button, stop playback, press the [EJECT] button, and remove the test disc.

5-15. FOCUS BIAS CHECK

Change the focus bias and check the focus tolerance amount.

Checking Procedure :

1. Load a continuously recorded test disc (MDW-74/GA-1). (Refer to "5-5. Using the Continuously Recorded Disc".)
2. Rotate the [◀◀ AMS ▶▶] knob and display "CPLAY1 MODE".
3. Press the [YES] button twice and display "CPLAY1 MID".
4. The display change to "C = [] AD = []".
5. Press the [MENU/NO] button and display "CPLAY1 MODE".
6. Rotate the [◀◀ AMS ▶▶] knob and display "FBIAS CHECK".
7. Press the [YES] button and display "[]/[] c = []".
The first four digits indicate the C error rate, the two digits after [/] indicate ADR, and the 2 digits after [c =] indicate the focus bias value.
Check that the C error is below 50 and ADER is below 2.
8. Press the [YES] button and display "[]/[] b = []".
Check that the C error is below 100 and ADER is below 2.
9. Press the [YES] button and display "[]/[] a = []".
Check that the C error is below 100 and ADER is below 2.
10. Press the [MENU/NO] button, next press the [EJECT] button, and remove the continuously recorded disc.

Note 1 : If the C error and ADER are above other than the specified value at points a (step 9. in the above) or b (step 8. in the above), the focus bias adjustment may not have been carried out properly. Adjust perform the beginning again.

5-16. AUTO GAIN CONTROL OUTPUT LEVEL ADJUSTMENT

Be sure to perform this adjustment when the Optical pick-up is replaced.

If the adjustment results becomes "Adjust NG!", the Optical pick-up may be faulty or the servo system circuits may be abnormal.

5-16-1. CD Auto Gain Control Output Level Adjustment**Adjusting Procedure :**

1. Insert the check disc (MD) TDYS-1.
2. Rotate the [◀◀ AMS ▶▶] knob to display "AG Set (CD)".
3. When the [YES] button is pressed, the adjustment will be performed automatically.
"Complete!" will then be displayed momentarily when the value is recorded in the non-volatile memory, after which the display changes to "AG Set (CD)".
4. Press the [EJECT] button to remove the disc.

5-16-2. MO Auto Gain Control Output Level Adjustment**Adjusting Procedure :**

1. Insert the reference disc (MDW-74/GA-1) for recording.
2. Rotate the [◀◀ AMS ▶▶] knob to display "AG Set (MO)".
3. When the [YES] button is pressed, the adjustment will be performed automatically.
"Complete!" will then be displayed momentarily when the value is recorded in the non-volatile memory, after which the display changes to "AG Set (MO)".
4. Press the [EJECT] button to remove the disc.

5-17. ADJUSTING POINTS AND CONNECTING POINTS

[BD BOARD] (SIDE A)

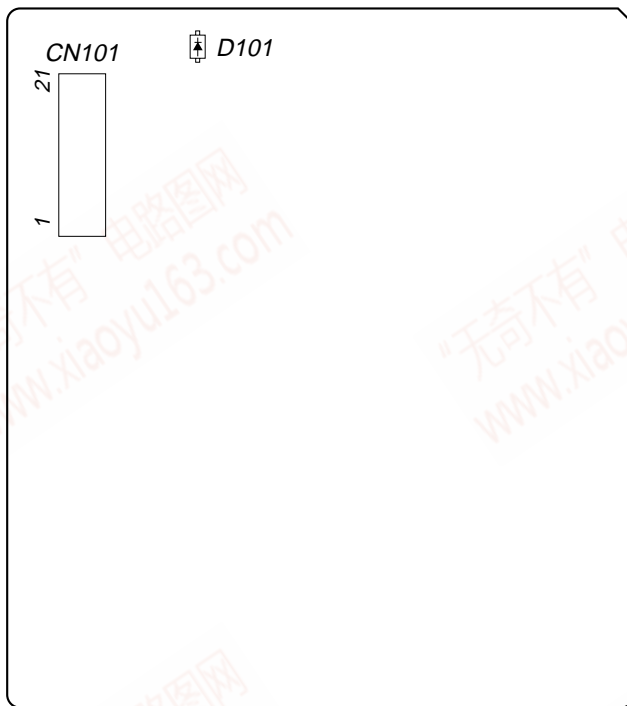

[BD BOARD] (SIDE B)

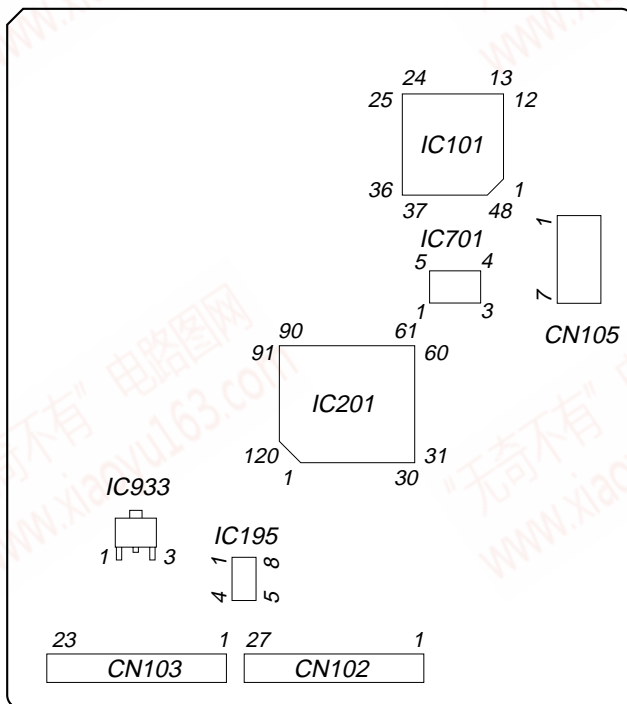

NOTE:It is useful to use the jig. for checking the waveform. (Refer to Servicing Note on page 6.)

SECTION 6 DIAGRAMS

6-1. CIRCUIT BOARDS LOCATION

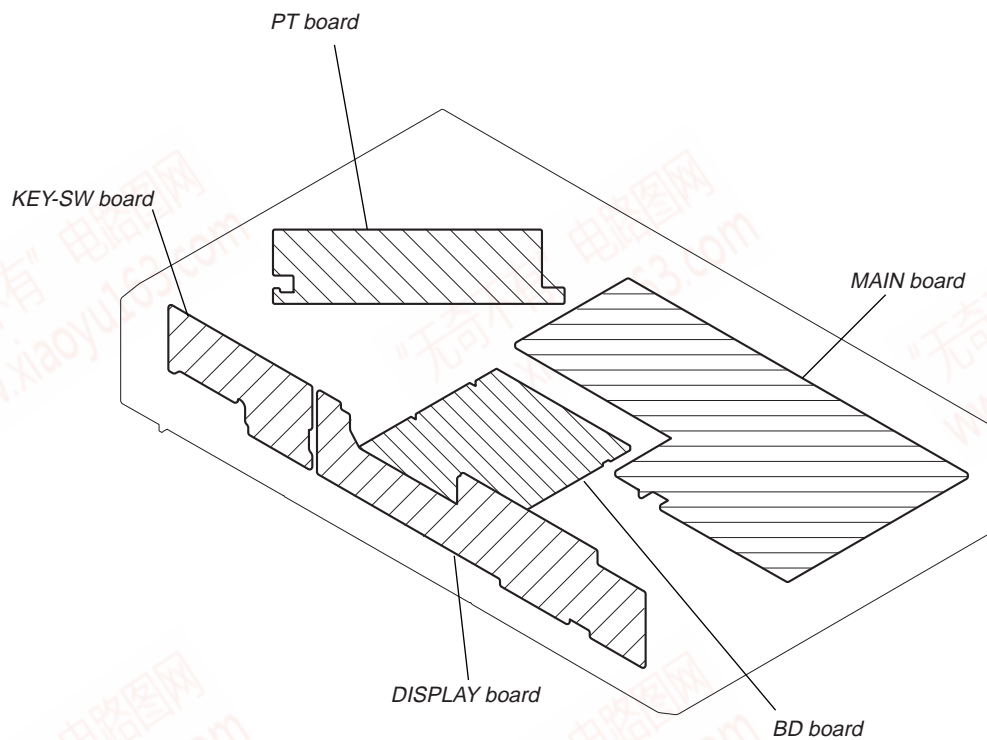

THIS NOTE IS COMMON FOR PRINTED WIRING BOARDS AND SCHEMATIC DIAGRAMS.
 (In addition to this, the necessary note is printed in each block.)

For schematic diagrams.

Note:

- All capacitors are in μF unless otherwise noted. pF: μF 50 WV or less are not indicated except for electrolytics and tantalums.
- All resistors are in Ω and $1/4\text{W}$ or less unless otherwise specified.
- Δ : internal component.
- \square : panel designation.

Note:

The components identified by mark Δ or dotted line with mark Δ are critical for safety. Replace only with part number specified.

- : B+ Line.
- : B- Line.
- : adjustment for repair.
- Voltages and waveforms are dc with respect to ground under no-signal (detuned) conditions.
- no mark : STOP
- () : PLAY
- < > : REC
- * : Impossible to measure
- Voltages are taken with a VOM (Input impedance 10 M Ω). Voltage variations may be noted due to normal production tolerances.
- Waveforms are taken with a oscilloscope. Voltage variations may be noted due to normal production tolerances.
- Circled numbers refer to waveforms.
- Signal path.
- : PB
- : REC
- : REC (DIGITAL IN)

For printed wiring boards.

Note:

- : parts extracted from the component side.
- : parts extracted from the conductor side.
- : Through hole.
- : Pattern from the side which enables seeing. (The other layers' patterns are not indicated.)

Caution:

Pattern face side: Parts on the pattern face side seen from the (Side B) pattern face are indicated.
 Parts face side: Parts on the parts face side seen from the (Side A) parts face are indicated.

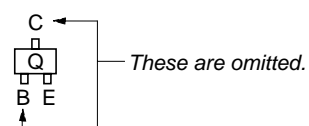
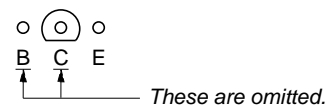

• WAVEFORMS

- BD Board -

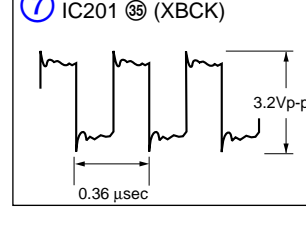
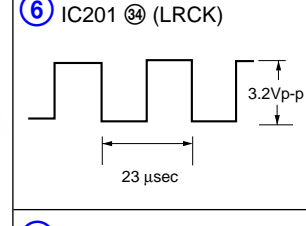
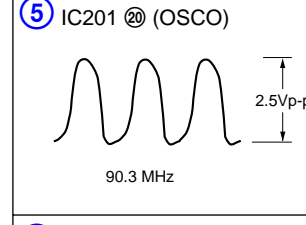
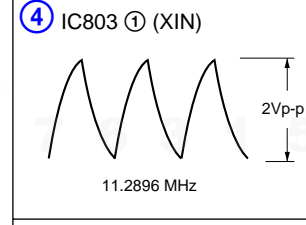
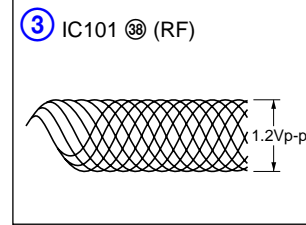
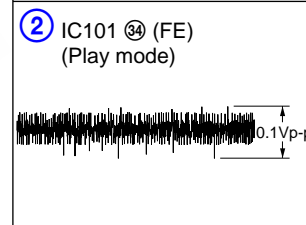
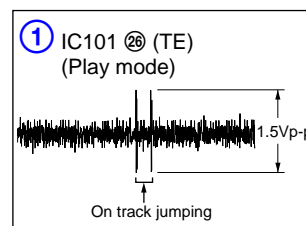

- MAIN Board -

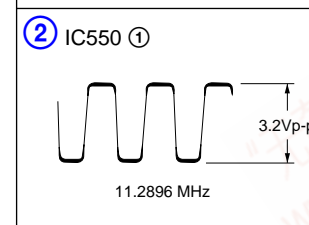
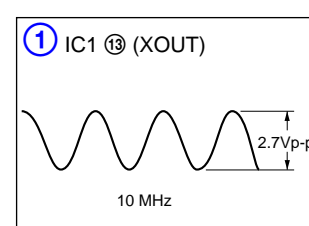

- PANEL Board -

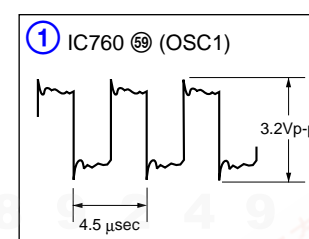

6-2. BLOCK DIAGRAMS - BD SECTION -

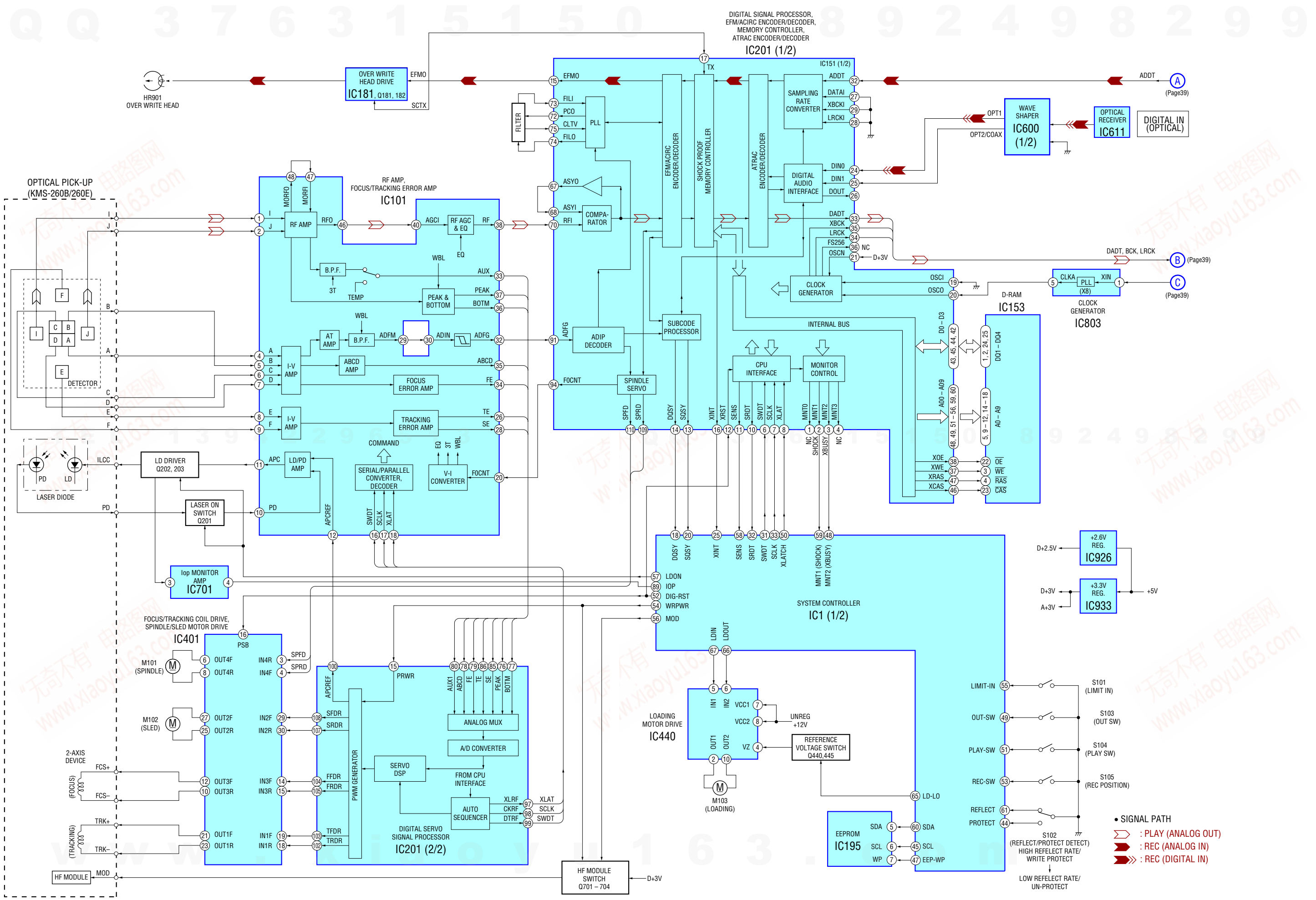

- MAIN SECTION -

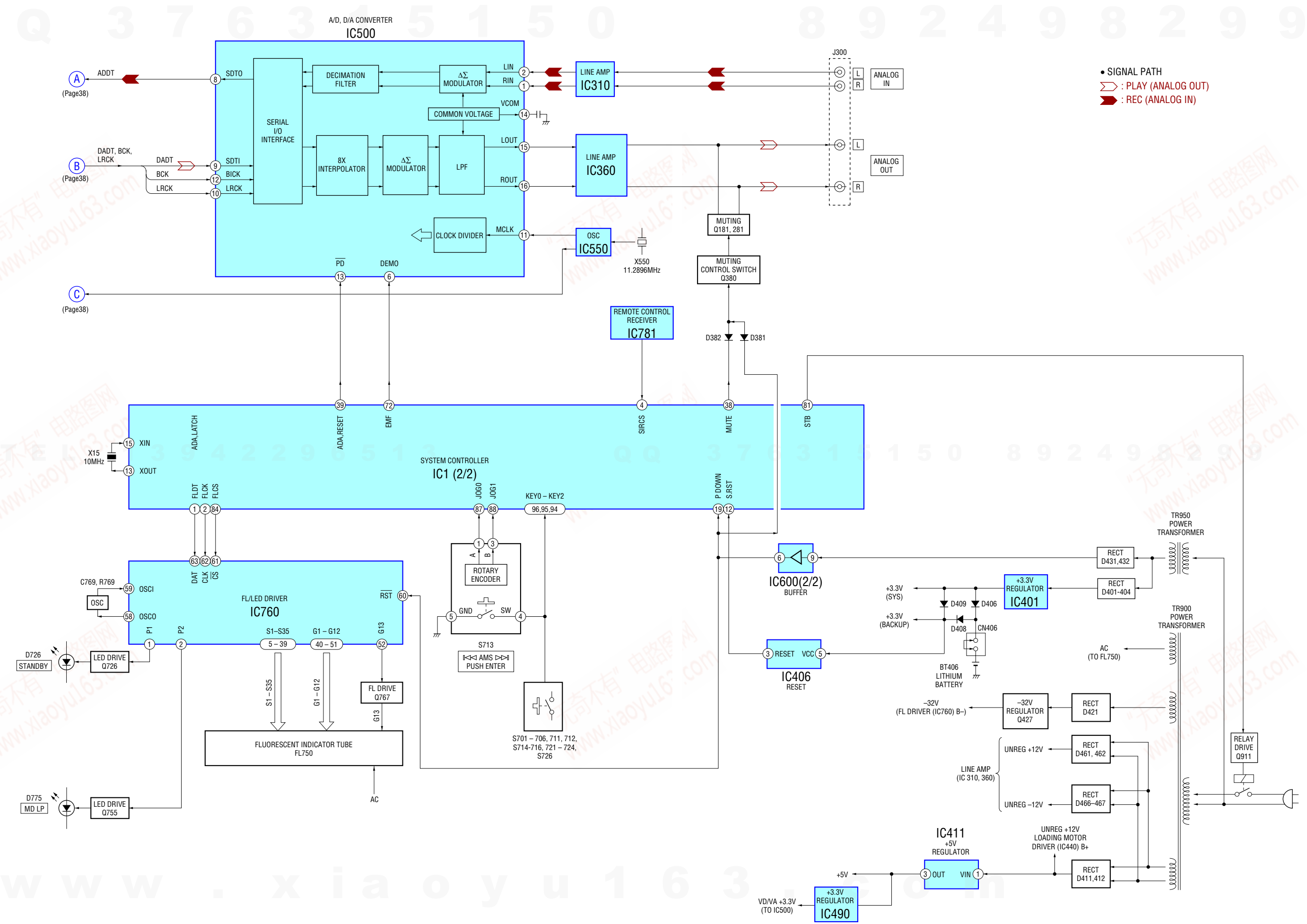

6-3. PRINTED WIRING BOARD – BD Board – • See page 36 for Circuit Board Location.

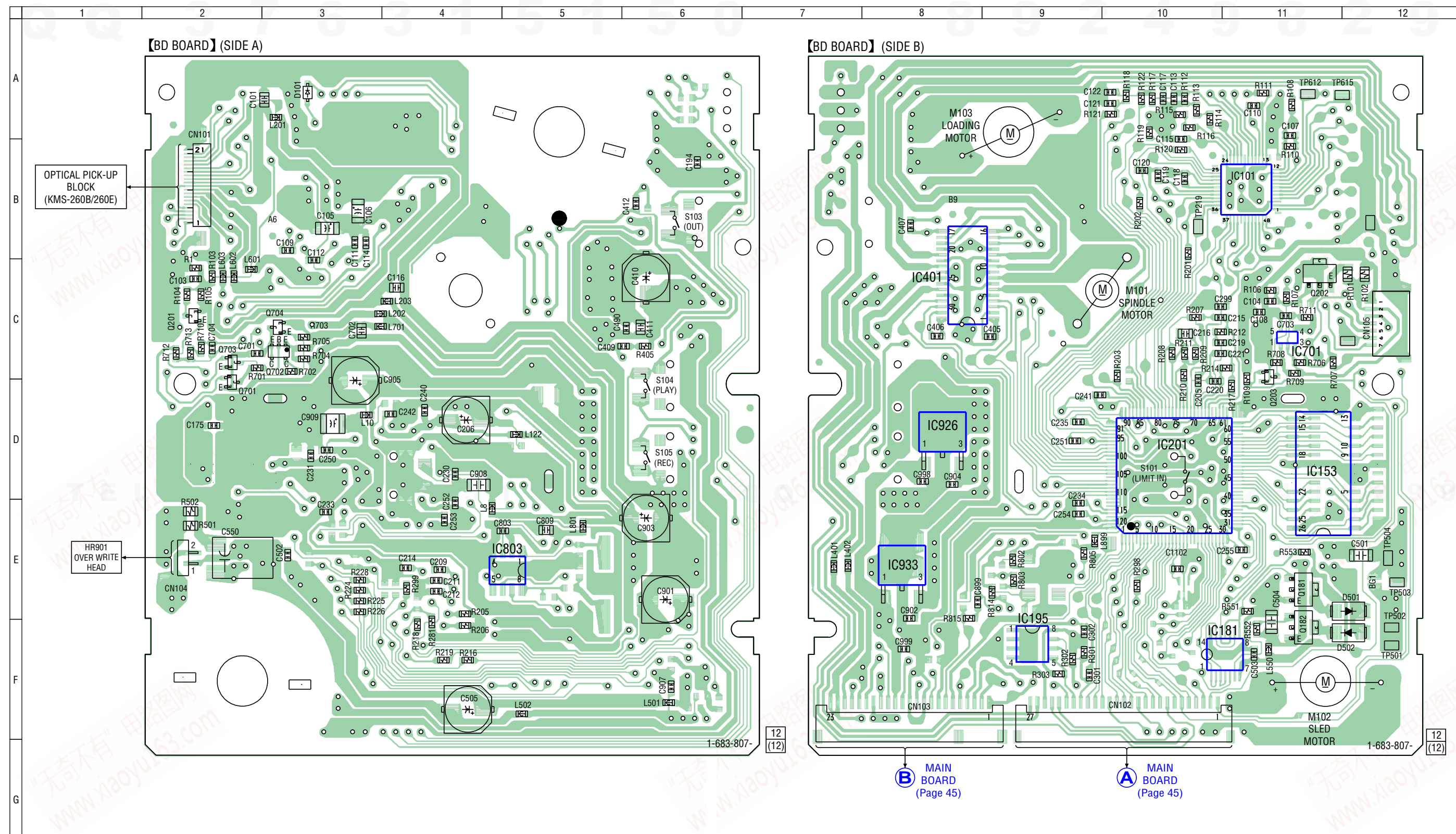

• Semiconductor Location

Ref. No.	Location	Ref. No.	Location	Ref. No.	Location
D101	A-3	IC701	C-11	Q701	D-2
D501	E-12	IC803	E-5	Q702	C-3
D502	F-12	IC926	D-8	Q703	C-2
		IC933	E-8	Q704	C-3
IC101	B-11	Q181	E-11		
IC153	D-11	Q182	F-11		
IC181	F-11	Q201	C-2		
IC195	F-9	Q202	C-11		
IC201	D-10	Q203	C-11		
IC401	C-8				

6-4. SCHEMATIC DIAGRAM – BD SECTION (1/2) – See page 49 for IC Pin Functions.

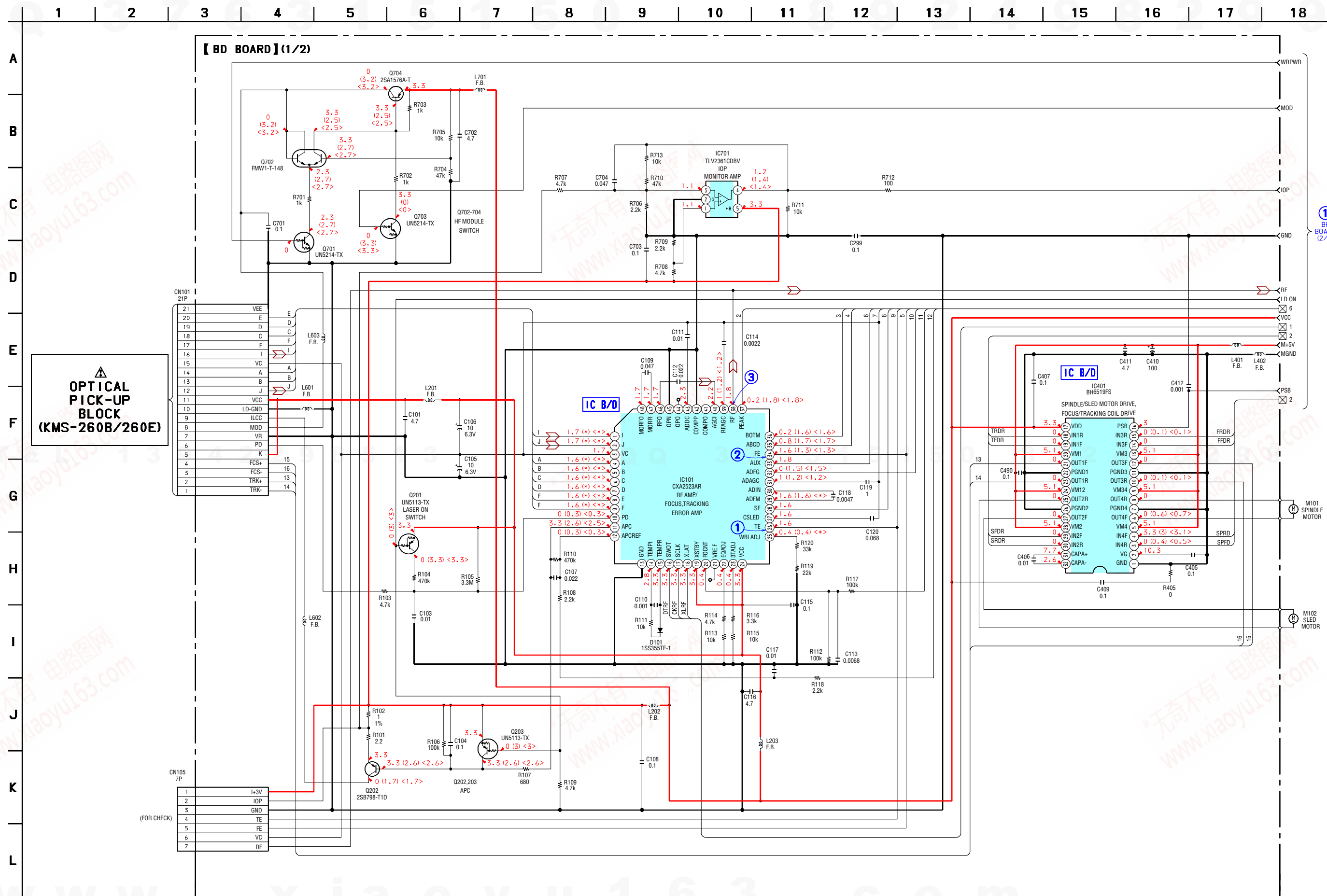

OPTICAL PICK-UP BLOCK (KMS-260B/260E)

(FOR CHECK)

①
BD BOARD (2/2)

6-6. SCHEMATIC DIAGRAM – MAIN SECTION (1/2) – • See page 53 for IC Pin Functions.

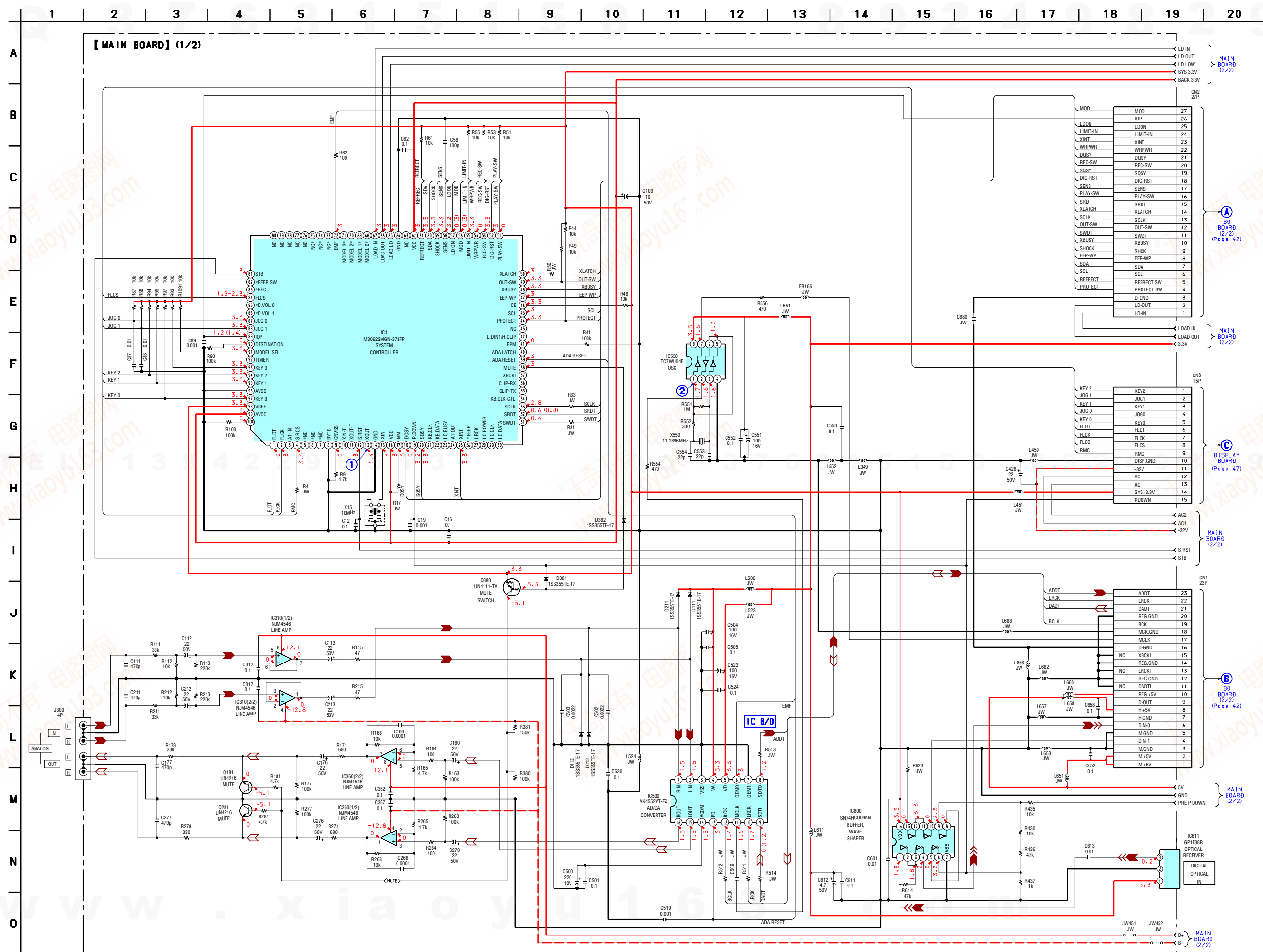

6-7. SCHEMATIC DIAGRAM – MAIN SECTION (2/2) –

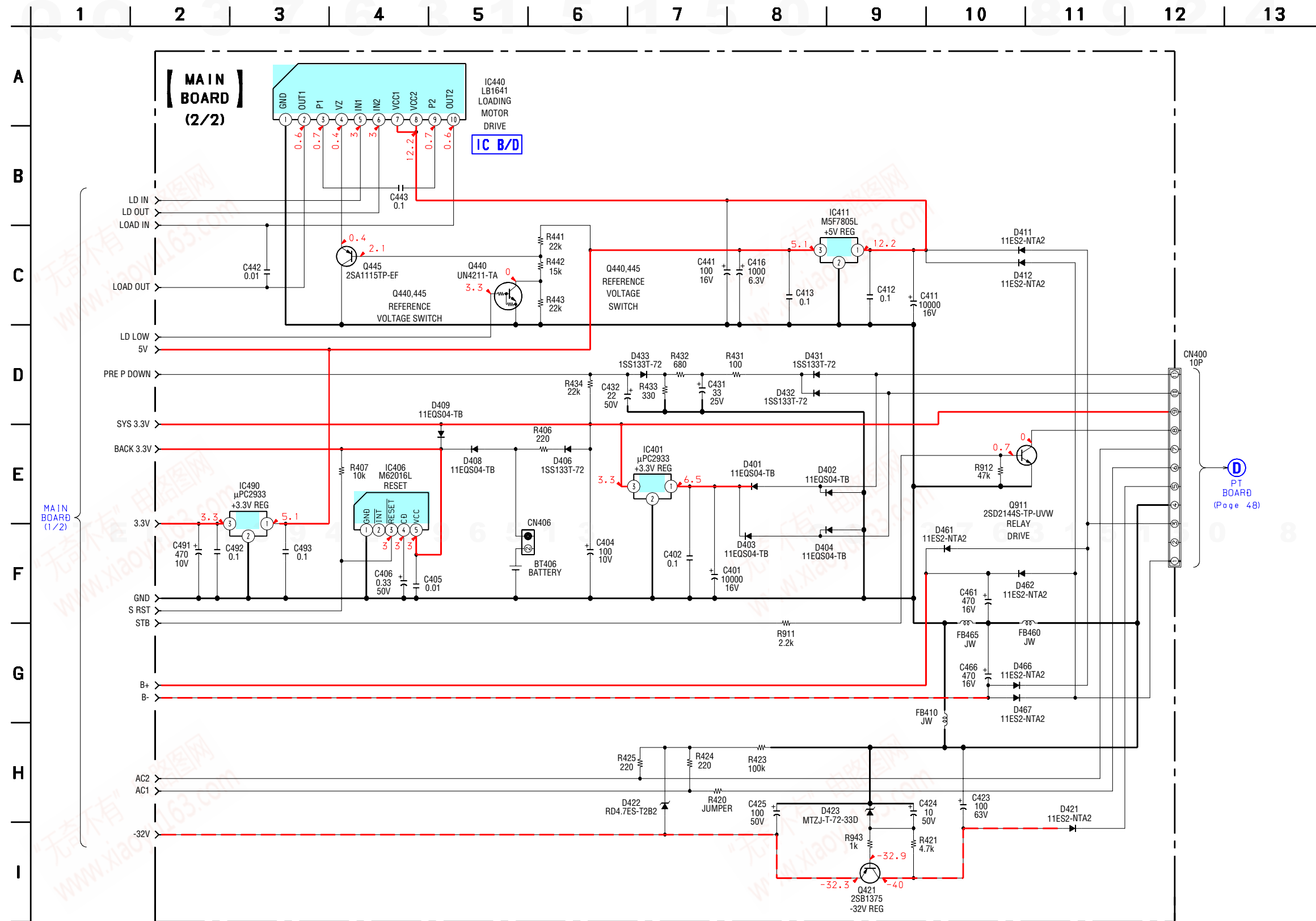

PT BOARD (Page 48)

6-8. PRINTED WIRING BOARD – MAIN SECTION – • See page 36 for Circuit Board Location.

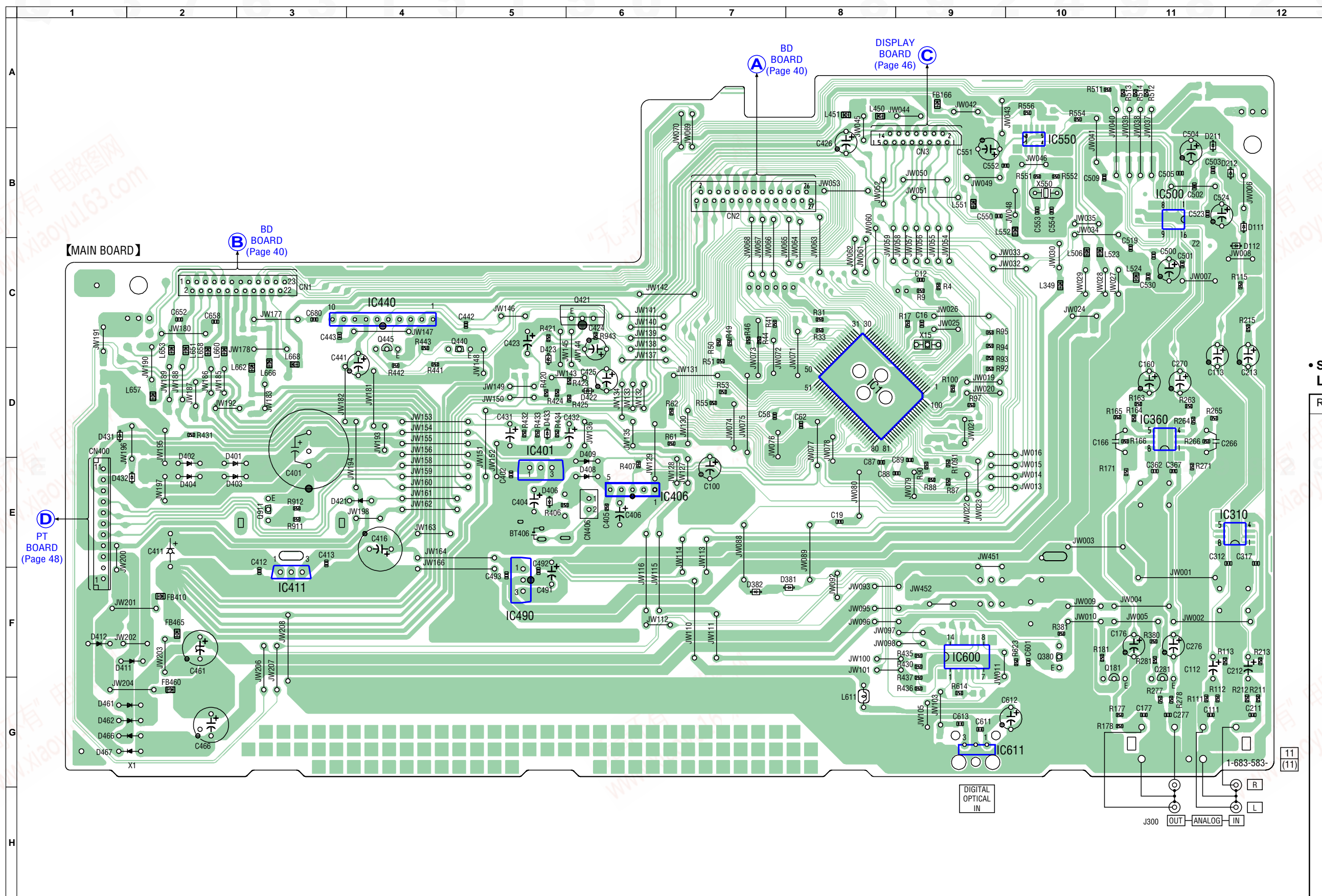

• Semiconductor Location

Ref. No.	Location
D111	B-12
D112	C-12
D211	B-11
D212	B-12
D381	F-8
D382	F-7
D401	E-2
D402	E-2
D403	E-2
D404	E-2
D406	E-5
D408	E-6
D409	E-6
D411	F-2
D412	F-1
D421	E-4
D422	D-6
D423	D-5
D431	D-1
D432	E-2
D433	D-5
D461	G-2
D462	G-2
D466	G-2
D467	G-2
IC1	D-8
IC310	E-12
IC360	D-11
IC401	E-5
IC406	E-6
IC411	F-3
IC440	C-4
IC490	F-5
IC500	B-11
IC550	B-10
IC600	F-9
IC611	G-9
Q181	G-10
Q281	G-11
Q380	F-10
Q421	C-6
Q440	D-5
Q445	D-4
Q911	E-3

6-9. PRINTED WIRING BOARD – DISPLAY SECTION – • See page 36 for Circuit Board Location.

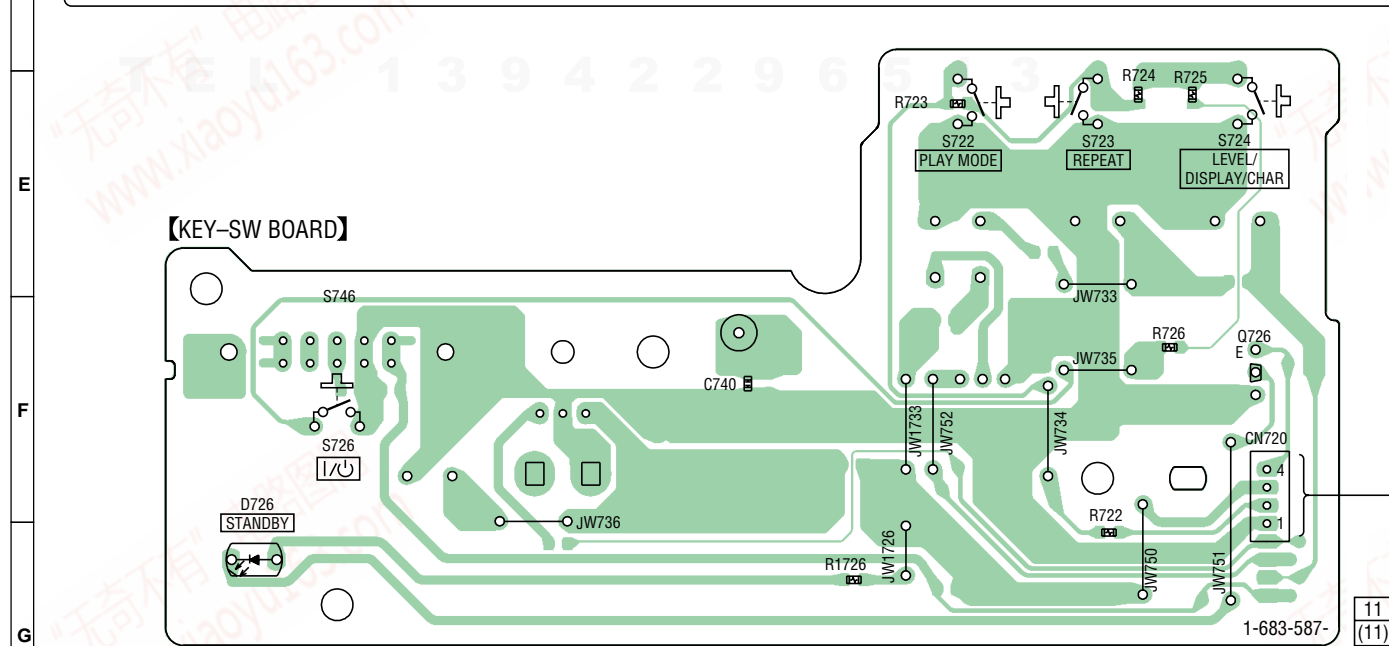
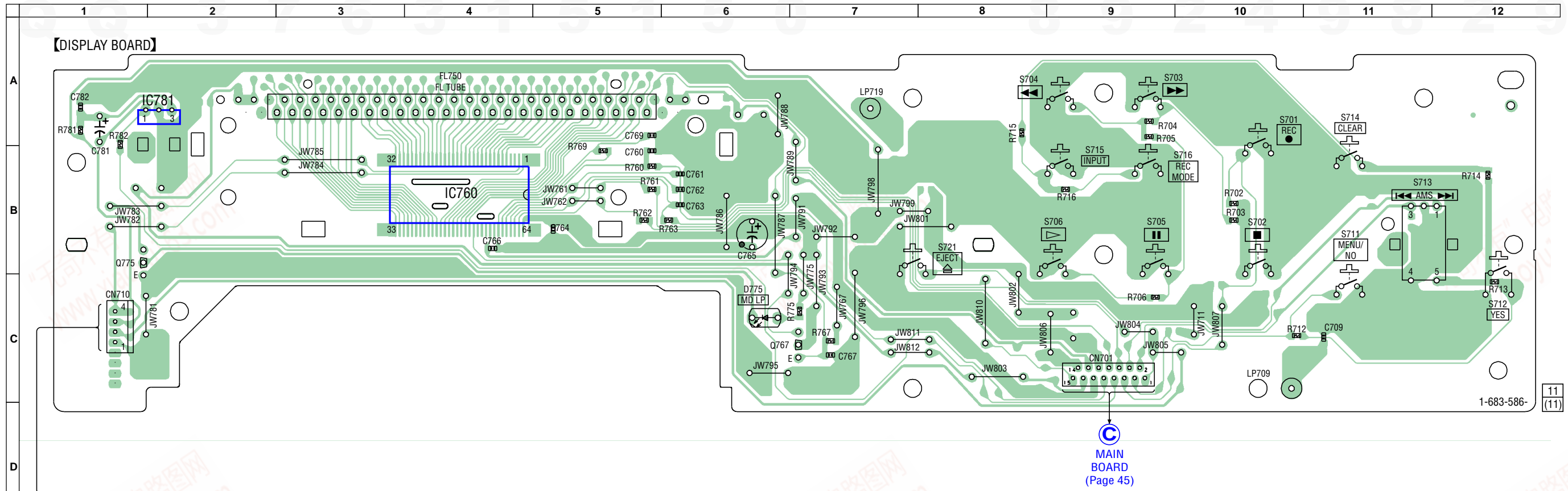

• Semiconductor Location

Ref. No.	Location
D726	G-1
D775	C-6
IC760	B-4
IC781	A-2
Q726	F-6
Q767	C-7
Q775	B-1

6-10. SCHEMATIC DIAGRAM - DISPLAY SECTION -

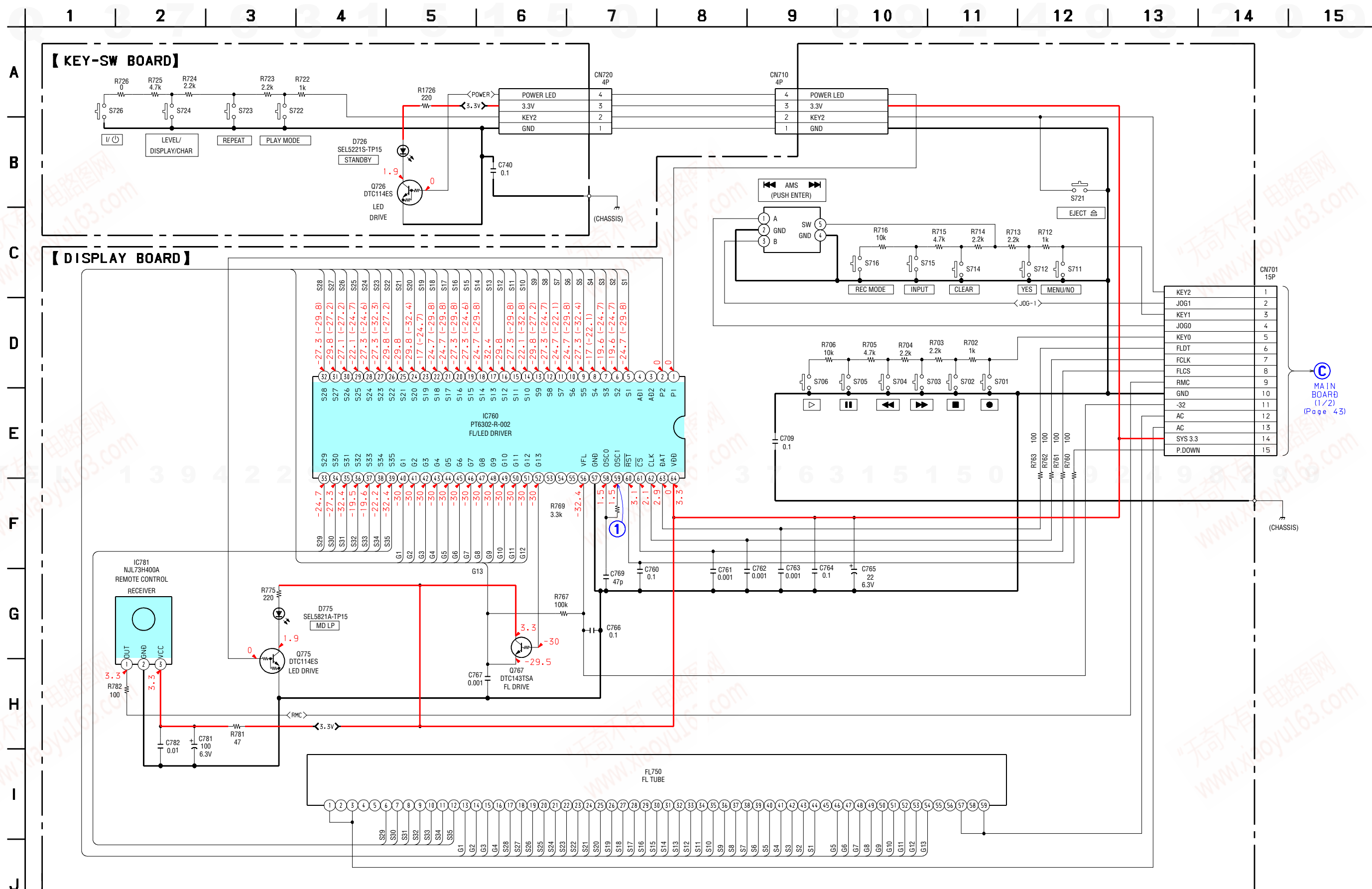

MAIN BOARD (1/2) (Page 43)

6-11. PRINTED WIRING BOARD – POWER SECTION – • See page 36 for Circuit Board Location.

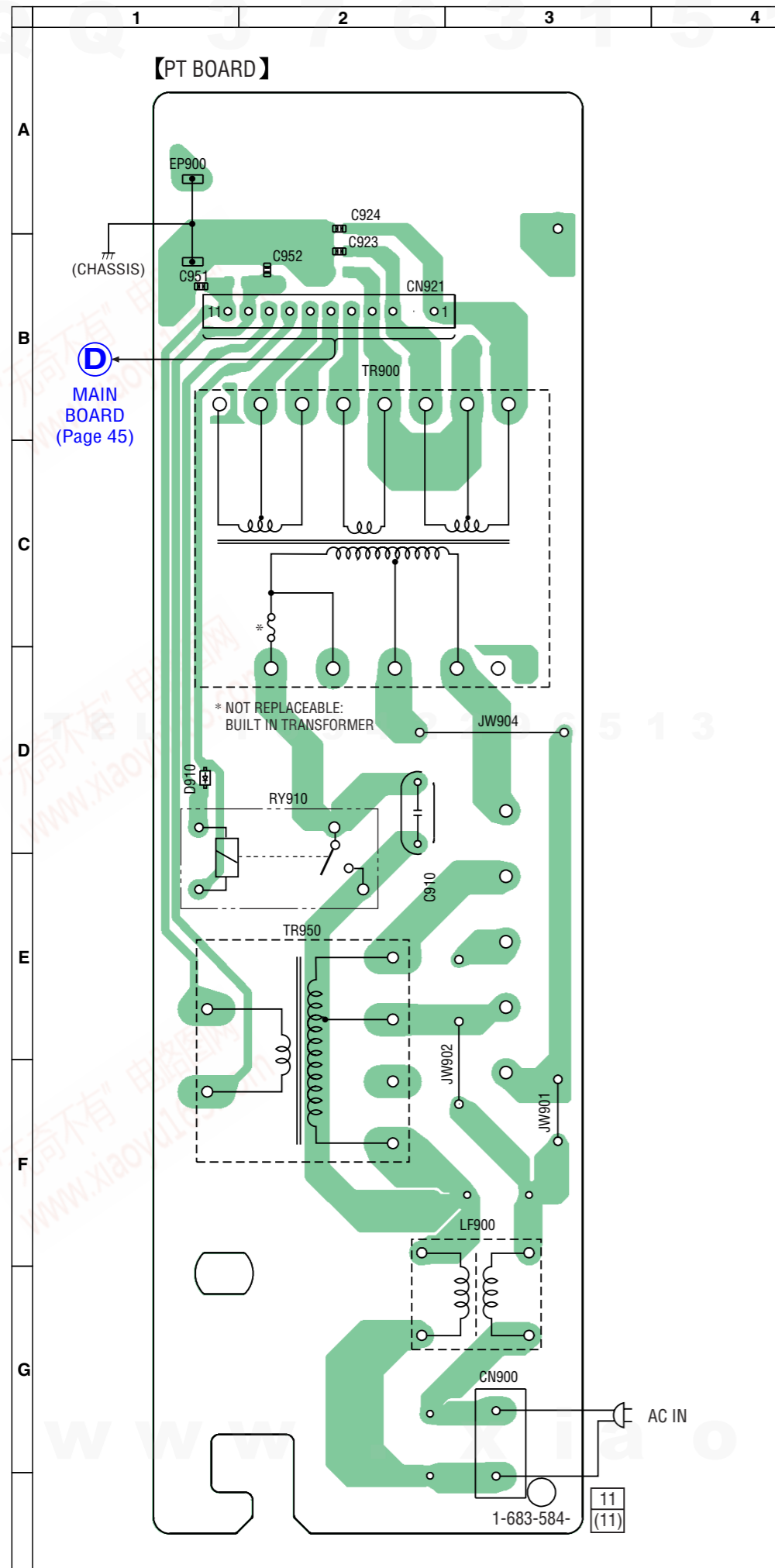

6-12. SCHEMATIC DIAGRAM – POWER SECTION –

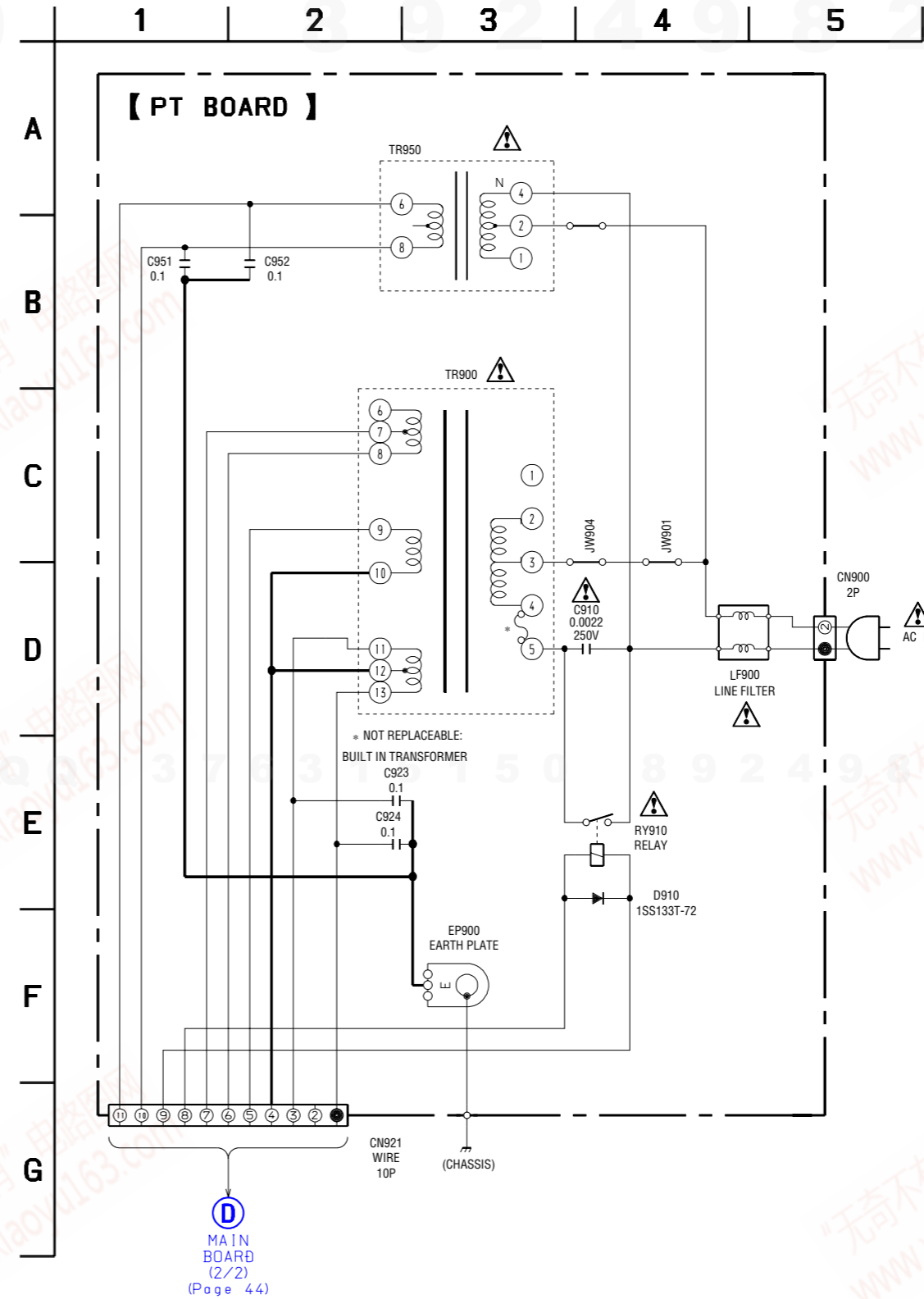

TEL 13942296513 QQ 376315150 892498299

TEL 13942296513 QQ 376315150 892498299

6-13. IC PIN FUNCTION DESCRIPTION

• IC101 CXA2523AR RF Amplifier (BD BOARD)

Pin No.	Pin Name	I/O	Description
1	I	I	I-V converted RF signal I input
2	J	I	I-V converted RF signal J input
3	VC	O	Middle point voltage generation output
4 - 9	A to F	I	Signal input from the optical pick-up detector
10	PD	I	Light amount monitor input
11	APC	O	Laser APC output
12	APCREF	I	Reference voltage input for setting laser power
13	GND	—	Ground
14	TEMPI	I	Temperature sensor connection
15	TEMPR	O	Reference voltage output for the temperature sensor
16	SWDT	I	Serial data input from the CXD2664R
17	SCLK	I	Serial clock input from the CXD2664R
18	XLAT	I	Latch signal input from the CXD2664R “L”: Latch
19	XSTBY	I	Stand by signal input “L”: Stand by
20	F0CNT	I	Center frequency control voltage input of BPF22, BPF3T, EQ from the CXD2664R
21	VREF	O	Reference voltage output (Not used)
22	EQADJ	I	Center frequency setting pin for the internal circuit EQ
23	3TADJ	I	Center frequency setting pin for the internal circuit BPF3T
24	Vcc	—	Power supply
25	WBLADJ	I	Center frequency setting pin for the internal circuit BPF22
26	TE	O	Tracking error signal output to the CXD2664R
27	CSLED	—	External capacitor connection pin for the sled error signal LPF
28	SE	O	Sled error signal output to the CXD2664R
29	ADFM	O	FM signal output of ADIP
30	ADIN	I	ADIP signal comparator input ADFM is connected with AC coupling
31	ADAGC	—	External capacitor connection pin for AGC of ADIP
32	ADFG	O	ADIP duplex signal output to the CXD2664R
33	AUX	O	I3 signal/temperature signal output to the CXD2664R
34	FE	O	Focus error signal output to the CXD2664R
35	ABCD	O	Light amount signal output to the CXD2664R
36	BOTM	O	RF/ABCD bottom hold signal output to the CXD2664R
37	PEAK	O	RF/ABCD peak hold signal output to the CXD2664R
38	RF	O	RF equalizer output to the CXD2664R
39	RFAGC	—	External capacitor connection pin for the RF AGC circuit
40	AGCI	I	Input to the RF AGC circuit The RF amplifier output is input with AC coupling
41	COMPO	O	User comparator output (Not used)
42	COMPP	I	User comparator input (Fixed at “L”)
43	ADDC	—	External capacitor pin for cutting the low band of the ADIP amplifier
44	OPO	O	User operation amplifier output (Not used)
45	OPN	I	User operation amplifier inversion input (Fixed at “L”)
46	RFO	O	RF amplifier output
47	MORFI	I	Groove RF signal is input with AC coupling
48	MORFO	O	Groove RF signal output

• Abbreviation

APC: Auto Power Control

AGC: Auto Gain Control

MDS-JE480

• IC201 CXD2664R Digital Signal Processor, Digital Servo Signal Processor (BD BOARD)

Pin No.	Pin Name	I/O	Description
1	MNT0 (FOK)	O	Not used (open)
2	MNT1 (SHCK)	O	Track jump detection signal output to the system control
3	MNT2 (XBUSY)	O	In the state of executire command signal output
4	MNT3 (SLOC)	O	Not used (open)
5	VDC0	—	Power supply
6	SWDT	I	Serial data input from the system control
7	SCLK	I	Serial clock signal input from the system control
8	XLAT	I	Serial latch signal input from the system control
9	VSC0	—	Ground
10	SRDT	O (3)	Serial reading data output to the system control
11	SENS	O (3)	Internal status (SENSE) output to the system control
12	XRST	I	Reset signal input from the system control “L”: Reset
13	SQSY	O	Subcode Q sync (SCOR) output to the system control
14	DQSY	O	Digital In U-bit CD format or MD format subcode Q sync (SCOR) output to the system control
15	RPWR	I	Laser power switching input from the system control “H”: Recording, “L”: Playback
16	XINT	O	Interrupt status output to the system control
17	TX	O	Recording data output enable input from the system control
18	VDIO0	—	Power supply
19	OSCI	I	System clock input (Fixed at “L”)
20	OSCO	I/O	System clock input (Input terminal during OSCN:“H”)
21	OSCN	I	Internal oscillating circuit control signal input
22	VSIO0	—	Ground
23	XTSL	I	System clock frequency setting
24	DIN0	I	Digital audio input (Optical input)
25	DIN1	I	Digital audio input (Optical input) (Not used)
26	DOUT	O	Digital audio output (Optical output) (Not used)
27	DADTI	I	Serial data input
28	LRCKI	I	LR clock input
29	XBCKI	I	Serial data bit clock input
30	VDC1	—	Power supply
31	VSC1	—	Ground
32	ADDT	I	Data input from the A/D converter
33	DADT	O	Data output to the D/A converter
34	LRCK	O	LR clock output for the A/D and D/A converter
35	XBCK	O	Bit clock output to the A/D and D/A converter
36	FS256	O	256Fs clock output (Not used)
37	XWE	O	Write enable signal output for DRAM
38	XOE	O	Read enable output for DRAM
39	DRVDD0	—	Power supply
40	DRVSS0	—	Ground
41	A11	O	DRAM address output (Not used) (Open)
42	D3	I/O	Data input/output for DRAM
43	D0	I/O	
44	D2	I/O	
45	D1	I/O	

* O (3) for 3-state output in the column I/O

Pin No.	Pin Name	I/O	Description
46	XCAS	O	CAS signal output for DRAM
47	XRAS	O	RAS signal output for DRAM
48	A09	O	DRAM address output
49	A08	O	
50	A10	O	Not used (Open)
51	A07	O	DRAM address output
52	A00	O	
53	A06	O	
54	A01	O	
55	A05	O	
56	A02	O	
57	VDC2	—	Power supply
58	VSC2	—	Ground
59	A04	O	DRAM address output
60	A03	O	DRAM address output
61	DRVDD1	—	Power supply
62	DRVSS1	—	Ground
63	TEST0	I	Not used (Fixed at “L”)
64	TEST1	I	Not used (Fixed at “H”)
65	TEST2	I	Not used (Open)
66	AVD1	—	Power supply
67	ASYO	O	Play back EFM duplex signal output
68	ASYI	I (A)	Play back EFM comparator slice level input
69	BIAS	I (A)	Play back EFM comparator bias current input
70	RFI	I (A)	Play back EFM RF signal input
71	AVS1	—	Ground
72	PCO	O (3)	Phase comparison output for the recording/playback EFM master PLL
73	FILI	I (A)	Filter input for the recording/playback EFM master PLL
74	FILO	O (A)	Filter output for the recording/playback EFM master PLL
75	CLTV	I (A)	Internal VCO control voltage input for the recording/playback EFM master PLL
76	PEAK	I (A)	Light amount signal peak hold input
77	BOTM	I (A)	Light amount signal bottom hold input
78	ABCD	I (A)	Light amount signal input
79	FE	I (A)	Focus error signal input from the CXA2523AR
80	AUX1	I (A)	Auxiliary A/D input
81	VC	I (A)	Middle point voltage input from the CXA2523AR
82	ADIO	O (A)	Monitor output of the A/D converter input signal (Not used) (Open)
83	ADRT	I (A)	A/D converter operational range upper limit voltage input (Fixed at “H”)
84	ADRB	I (A)	A/D converter operational range lower limit voltage input (Fixed at “L”)
85	SE	I (A)	Sled error signal input from the CXA2523AR
86	TE	I (A)	Tracking error signal input from the CXA2523AR
87	AVD2	—	Power supply
88	AVS2	—	Ground
89	DCHG	I (A)	Connected to +3V power supply
90	APC	I	APC error signal input (Not used) (Fixed at “H”)
91	ADFG	I	ADIP duplex FM signal input from the CXA2523AR

* I (A) for analog input, O (3) for 3-state output, and O (A) for analog output in the column I/O

• Abbreviation

EFM: Eight to Fourteen Modulation

PLL : Phase Locked Loop

VCO: Voltage Controlled Oscillator

MDS-JE480

Pin No.	Pin Name	I/O	Description
92	VDIO1	—	Power supply
93	VSIO1	—	Ground
94	F0CNT	O	Filter f0 control output to the CXA2523AR
95	VDC3	—	Power supply
96	VSC3	—	Ground
97	XLRF	O	Control latch output to the CXA2523AR
98	CLRF	O	Control clock output to the CXA2523AR
99	DTRF	O	Control data output to the CXA2523AR
100	APCR	O	Reference PWM output for the laser APC
101	LDDR	O	PWM output for the laser digital APC (Not used) (Open)
102	TRDR	O	Tracking servo drive PWM output (-)
103	TFDR	O	Tracking servo drive PWM output (+)
104	FFDR	O	Focus servo drive PWM output (+)
105	FRDR	O	Focus servo drive PWM output (-)
106	FS4	O	4Fs clock signal output (Not used) (Open)
107	SRDR	O	Sled servo drive PWM output (-)
108	SFDR	O	Sled servo drive PWM output (+)
109	SPRD	O	Spindle servo drive PWM output (-)
110	SPFD	O	Spindle servo drive PWM output (+)
111	FGIN	I	Spindle CAV servo FG signal input
112-114	TST1 to TST3	I	Test input (Fixed at "L")
115	EFMO	O	EFM output when recording
116	VDIO2	—	Power supply
117	VSIO2	—	Ground
118	VDC4	—	Power supply
119	VSC4	—	Ground
120	MDDT1	I	MD data mode1 switching signal input (Fixed at "L")

• Abbreviation

EFM: Eight to Fourteen Modulation

• IC1 M30622MGN-373FP SYSTEM CONTROL (MAIN BOARD)

Pin No.	Pin Name	I/O	Description
1	FLDT	O	Serial data output to the display driver
2	FLCK	O	Serial clock signal output to the display driver. L: Active
3	A1-IN	I	A1 Control input (Not used) (Open)
4	SIRCS	I	Remote control input
5 - 7	NC	—	Not used
8	BYTE	I	Data bus changed input (Fixed at “L”)
9	CNVSS	—	Ground
10	XIN-T	I	Not used (Open)
11	XOUT-T	O	Not used (Open)
12	S.RST	I	System rest input
13	XOUT	O	Main clock output (10MHz)
14	GND	—	Ground
15	XIN	I	Main clock input (10MHz)
16	VCC	—	Power supply
17	NMI	I	Fixed at H (Fixed at “H”)
18	DQSY	I	Digital in sync input (Record system)
19	P.DOWN	I	Power down detection input L: Power down
20	SQSY	I	ADIP (MO) sync or subcode Q (PIT) sync input from CXD2664R (Playback system)
21	(KB.CLK)	I	Keyboard clock input (Not used) (Open)
22	(KB.DATA)	I	Keyboard data input (Not used) (Open)
23	(IIC BUSY)	I	IIC cable connect check (Not used) (Open)
24	(A1 OUT)	O	A1 control output (Not used) (Open)
25	XINIT	I	Interrupt status input from CXD2664R
26	*BEEP	O	Not used (Open)
27	(LRCKI)	O	Not used (Open)
28	(IIC POWER)	O	Not used (Open)
29	(IIC CLK)	O	Not used (Open)
30	(IIC DATA)	I/O	Not used (Open)
31	SWDT	O	Writing data signal output to the serial bus
32	SRDT	I	Reading data signal input from the serial bus
33	SCLK	O	Clock signal output to the serial bus
34	(KB.CLK-CTRL)	O	Keyboard clock ON/OFF signal output (Not used) (Open)
35	(CLIP-TX)	O	Not used (Open)
36	(CLIP-RX)	I	Not used (Open)
37	(XBCK1)	O	Not used (Open)
38	MUTE	O	Line out muting output
39	ADA.RESET	O	Reset signal output to the AK4552
40	ADA.LATCH	O	Latch signal output to the AK4552 (Not used) (Open)
41	EPN	I	Not used (Fixed at L)
42	(L : DINT1/H : CLIP)	O	Not used (Open)
43	NC	O	Not used (Open)
44	PROTECT	I	Recording-protection claw detection input from the protection detection switch H: Protect
45	SCL	O	Clock signal output to the EEP-ROM
46	CE	O	Not used (Pull-up)
47	EEP-WP	O	EEP-ROM write protect signal output L: write possibility
48	XBUSY	I	In the state of executive command from the CXD2664R

MDS-JE480

Pin No.	Pin Name	I/O	Description
49	OUT-SW	I	Detection signal input from the loading out detection switch
50	XLATCH	O	Latch signal output to the serial bus
51	PLAY-SW	I	Detection signal input from the playback position detection switch L: PLAY
52	DIG-RST	O	Digital rest signal output to the CXD2664R and motor driver
53	REC-SW	I	Detection signal input from the recording position detection switch L: REC
54	WR PWR	O	Write power ON/OFF output
55	LIMIT-IN	I	Detection input from the limit switch L: Sled limit-In H: Sled limit-Out
56	MOD	O	Laser modulation switching signal output
57	LDON	O	Laser ON/OFF control output
58	SENS	I	Internal status (SENSE) input from the CXD2664R
59	SHCK	I	Track jump signal input from the CXD2664R
60	SDA	I/O	Serial data input/output pin with the EEPROM
61	REFLECT	I	Disk reflection rate detection input from the reflect detection switch. H: Disk with low reflection rate
62	VCC	—	Power supply
63	NC	O	Not used (Open)
64	GND	—	Ground
65	LOAD LO	O	Loading motor voltage control output
66	LOAD OUT	O	Loading motor control output H: eject
67	LOAD IN	O	Loading motor control output H: loading
68 - 71	MODEL SEL 0 - 3	O	Not used (Open)
72	EMF	O	Deemphasis control signal output to the AK4552
73 - 80	NC	O	Not used (Open)
81	STB	O	Strobe signal output to the power supply circuit H: Power supply ON: L: standby
82	BEEP SW	O	Not used (Open)
83	REC	O	Not used (Open)
84	FLCS	O	Chip select signal output to the MSM9202
85, 86	D.VOL0,1	O	Not used (Open)
87, 88	JOG0, JOG1	I	Jog dial pulse input from the rotary encoder
89	IOP	I	Optical Pick-up voltage (current) detect signal input
90	DISTINATION	I	Model discrimination
91	MODEL SEL	I	Model discrimination
92	TIMER	I	Not used (Open)
93	KEY3	I	Not used (Fixed at "H")
94, 95	KEY2, 1	I	Key input pin (A/D input)
96	AVSS	—	Ground
97	KEY0	I	Key input pin (A/D input)
98	VREF	I	A/D reference voltage (Fixed at "H")
99	AVCC	—	Power supply
100	NC	I	Not used (Fixed at "L")

6-14. IC BLOCK DIAGRAMS
IC101 CXA2523AR (BD BOARD)

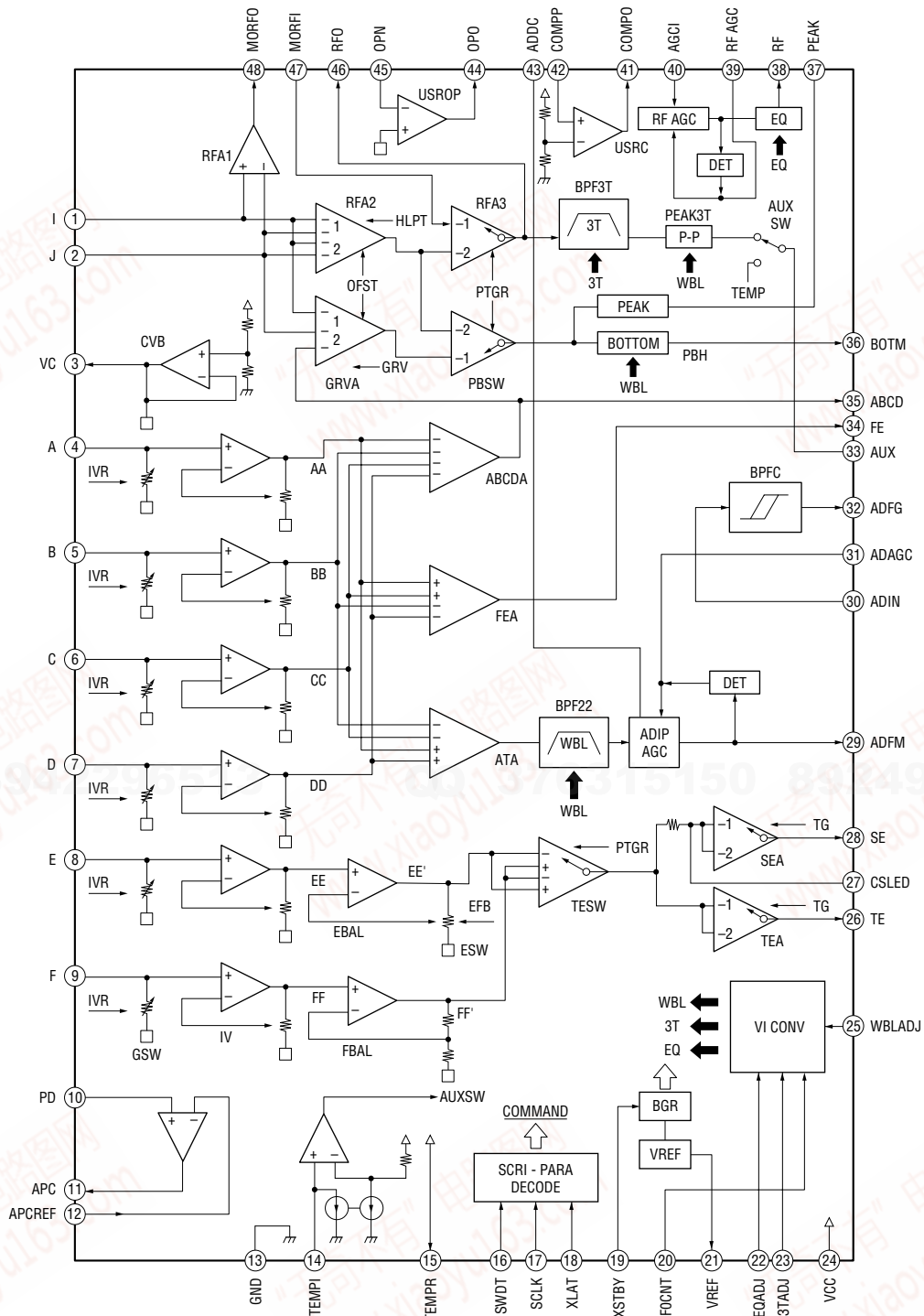

IC201 CXD2664R (BD BOARD)

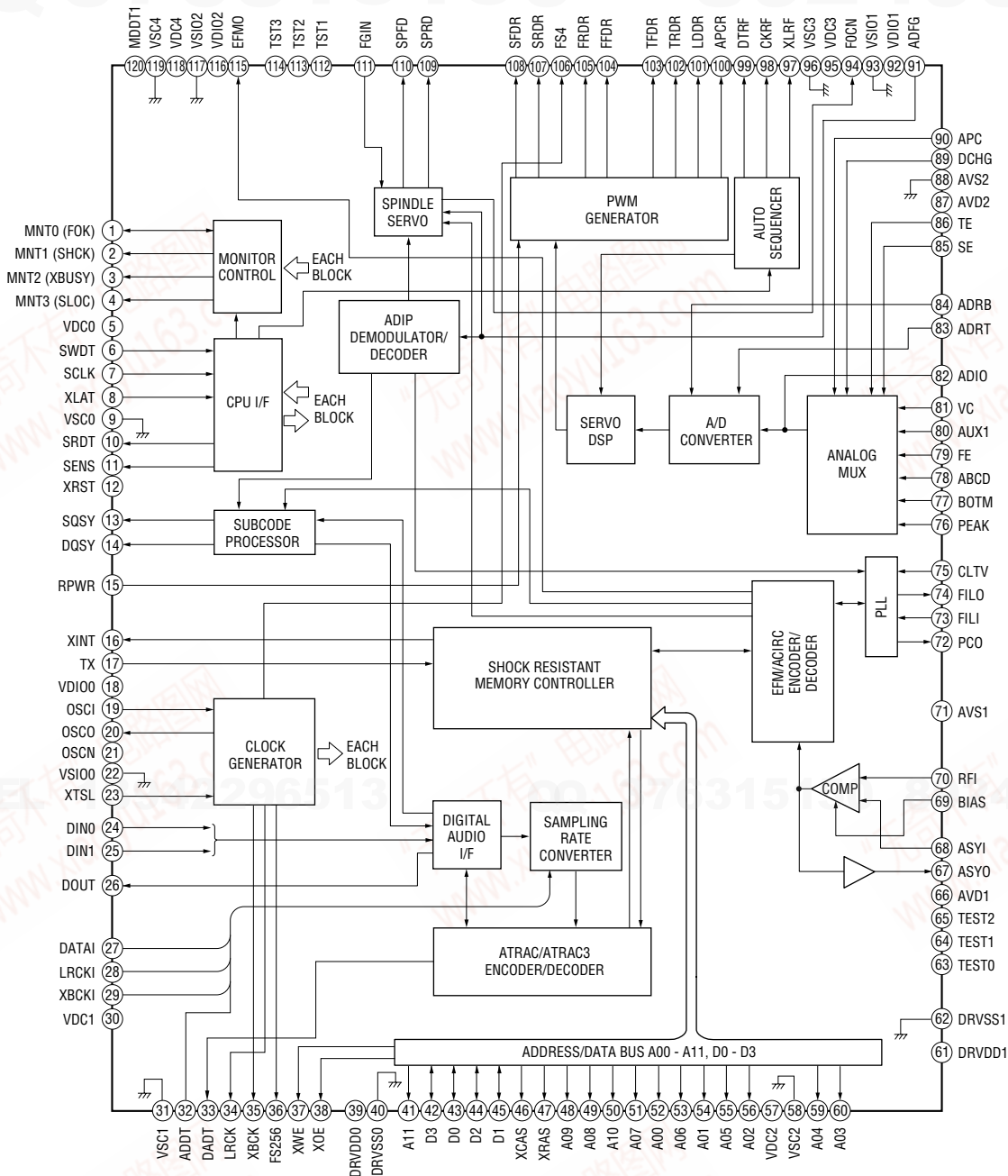

IC401 BH6519FS-E2 (BD BOARD)

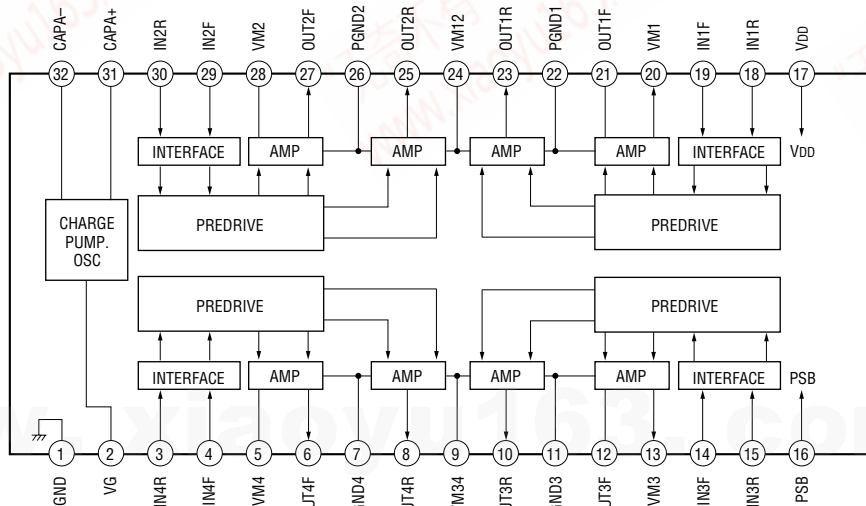

IC803 CY24115-2SCT (BD BOARD)

IC440 LB1641 (MAIN BOARD)

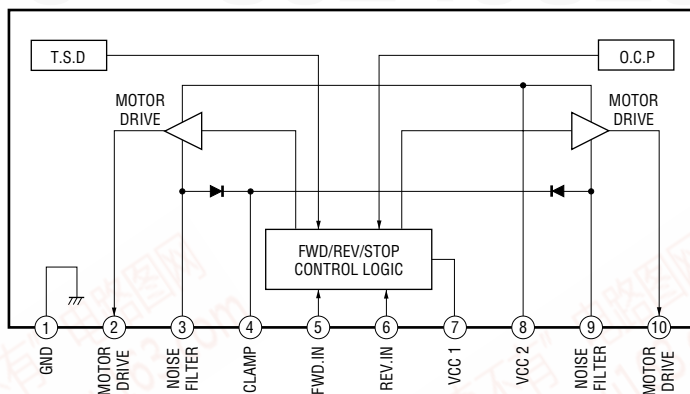
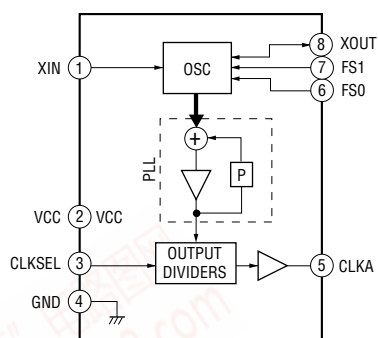

IC500 AK4552VT-E2 (MAIN BOARD)

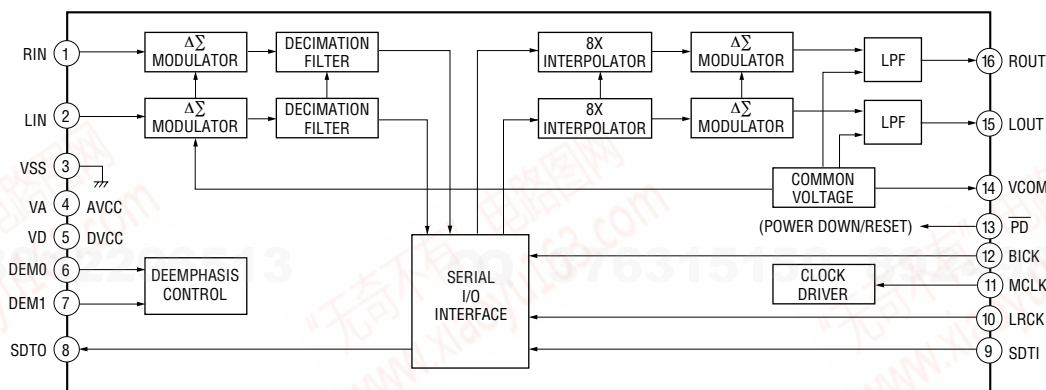

MDS-JE480

Ver. 1.4

**SECTION 7
EXPLODED VIEWS**

NOTE:

- XX, -X mean standardized parts, so they may have some differences from the original one.
- Items marked "*" are not stocked since they are seldom required for routine service. Some delay should be anticipated when ordering these items.
- The mechanical parts with no reference number in the exploded views are not supplied.
- Hardware (# mark) list and accessories and packing materials are given in the last of this parts list.

- Color indication of Appearance Parts
Example :
KNOB, BALANCE (WHITE)... (RED)
 ↑ ↑
 Parts color Cabinet's color
- Abbreviation
RU: Russian model

The components identified by mark Δ or dotted line with mark Δ are critical for safety. Replace only with part number specified.

7-1. CHASSIS SECTION

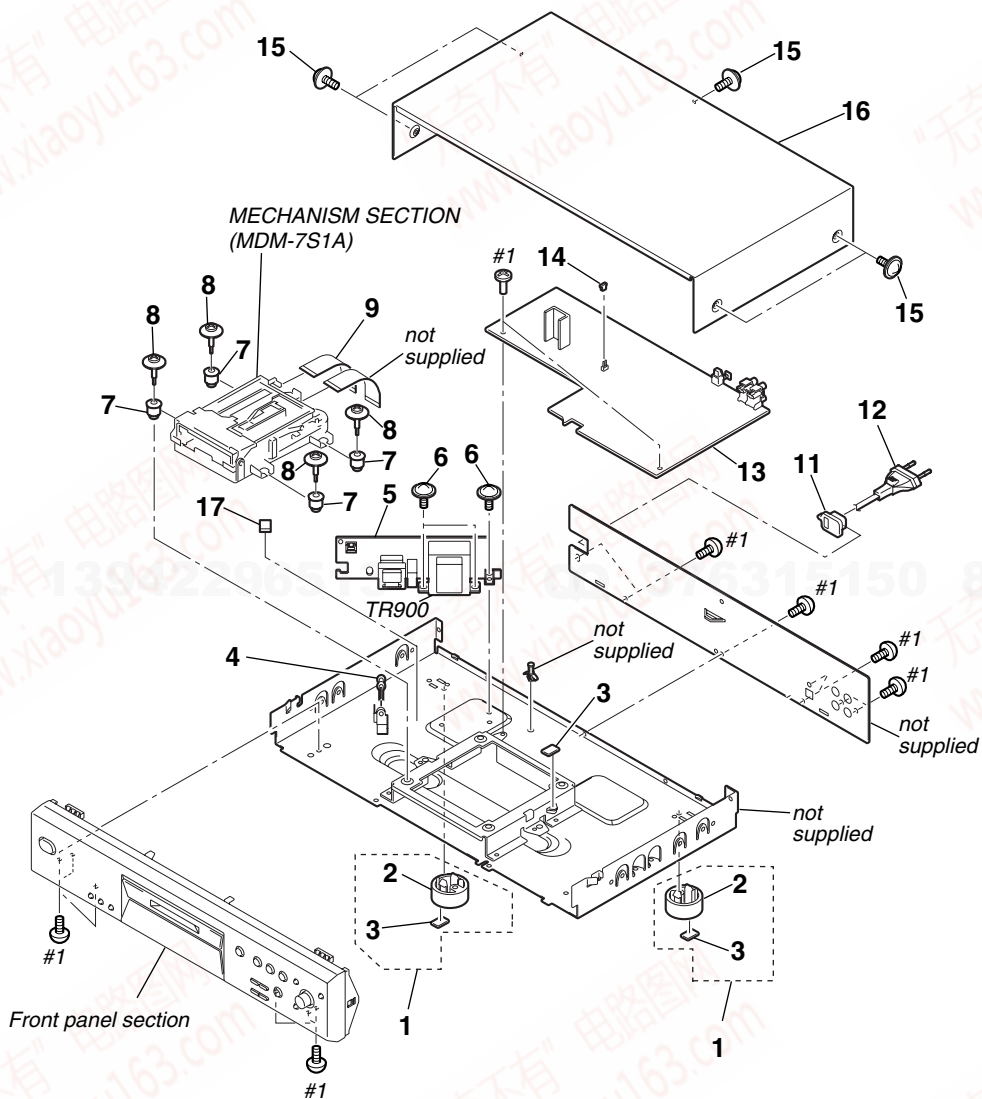

Ref. No.	Part No.	Description	Remarks	Ref. No.	Part No.	Description	Remarks
1	X-4953-448-1	FOOT ASSY		*	14	SOCKET, SHORT 2P	
2	4-232-237-01	FOOT (DIA. 30)		15	3-363-099-11	SCREW (CASE 3 TP2) ...(SILVER: for Hair-line Finish) (AEP, UK, RU)	
3	4-977-358-01	CUSHION		15	4-210-291-01	SCREW (CASE 3 TP2)...(BLACK)	
4	3-531-576-41	RIVET (DIA. 3), NYLON		15	4-210-291-11	SCREW (CASE 3 TP2)...(SILVER) (AEP, UK, RU)	
5	1-683-584-11	PT BOARD		16	2-660-400-31	CASE...(SILVER: for Hair-line Finish) (AEP, UK, RU)	
6	3-703-249-01	SCREW, S TIGHT, +PTTWH 3X6		16	4-232-149-31	CASE (408226)...(BLACK)	
7	4-231-555-01	INSULATOR		16	4-232-580-31	CASE (408226)...(SILVER) (AEP, UK, RU)	
8	4-228-643-11	SCREW (+BVTTWH M3), STEP		17	3-937-248-01	CUSHION (A)	
9	1-792-811-11	WIRE (FLAT TYPE) (23 CORE)		Δ TR900	1-435-543-11	TRANSFORMER, POWER (US)	
* 11	3-703-244-00	BUSHING (2104), CORD		Δ TR900	1-435-544-11	TRANSFORMER, POWER (AEP, UK, RU)	
Δ 12	1-777-071-63	CORD, POWER (AEP, UK, RU)		#1	7-685-646-79	SCREW +BVTP 3X8 TYPE2 N-S	
Δ 12	1-783-532-32	CORD, POWER (US)					
13	A-4727-954-A	MAIN BOARD, COMPLETE					

7-2. FRONT PANEL SECTION

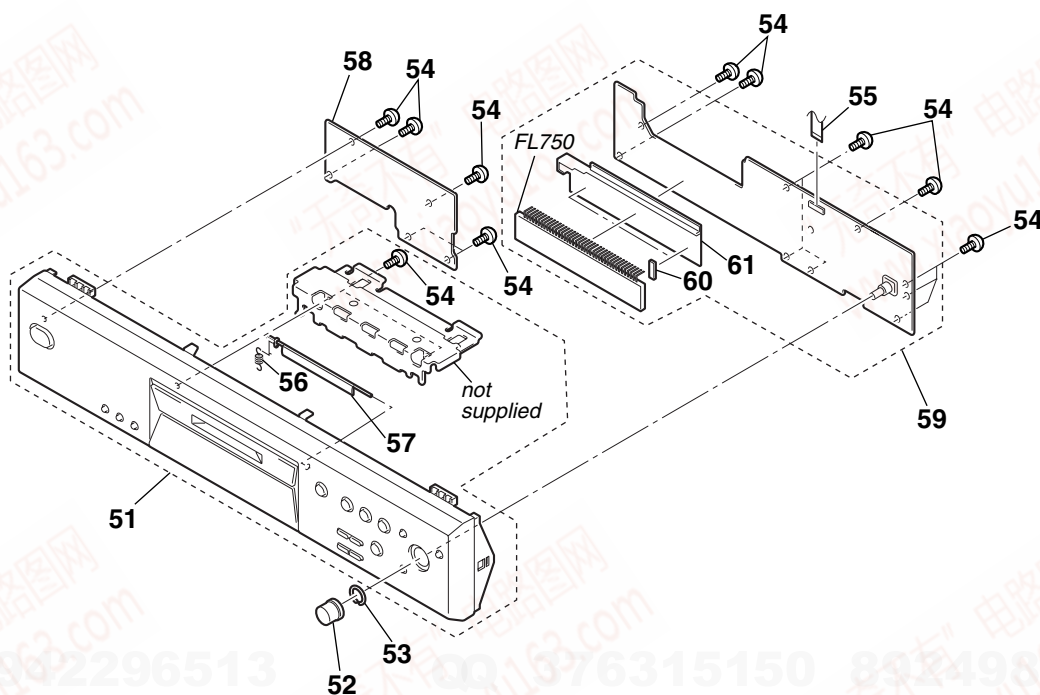

Ref. No.	Part No.	Description	Remarks	Ref. No.	Part No.	Description	Remarks
51	X-2103-027-1	FRONT PANEL ASSY...(SILVER : Hair-line Finish)	(AEP, UK, RU)	55	1-757-929-11	WIRE (FLAT TYPE) (15 CORE)	
51	X-4954-486-2	FRONT PANEL ASSY...(BLACK) (AEP, UK, RU)		56	4-228-630-01	SPRING (LID), TENSION COIL	
51	X-4954-487-1	FRONT PANEL ASSY...(SILVER) (AEP, UK, RU)		57	4-228-629-21	LID (MD)...(SILVER) (AEP, UK, RU)	
51	X-4955-740-1	FRONT PANEL ASSY...(BLACK) (US)		57	4-228-629-81	LID (MD)...(BLACK)	
52	4-231-928-01	KNOB (AMS)...(BLACK)		58	1-683-587-11	KEY-SW BOARD	
52	4-231-928-11	KNOB (AMS)...(SILVER) (AEP, UK, RU)		59	A-4727-955-A	DISPLAY BOARD, COMPLETE	
52	4-231-928-31	KNOB (AMS)...(SILVER : for Hair-line Finish)	(AEP, UK, RU)	60	4-949-935-41	CUSHION (FL)	
53	3-354-981-11	SPRING (SUS), RING		61	4-212-590-22	HOLDER (FL)	
54	4-951-620-01	SCREW (2.6X8), +BVTP		FL750	1-517-986-11	INDICATOR TUBE, FLUORESCENT	

MDS-JE480
Ver. 1.2

7-3. MECHANISM SECTION-1
(MDM-7S1A)

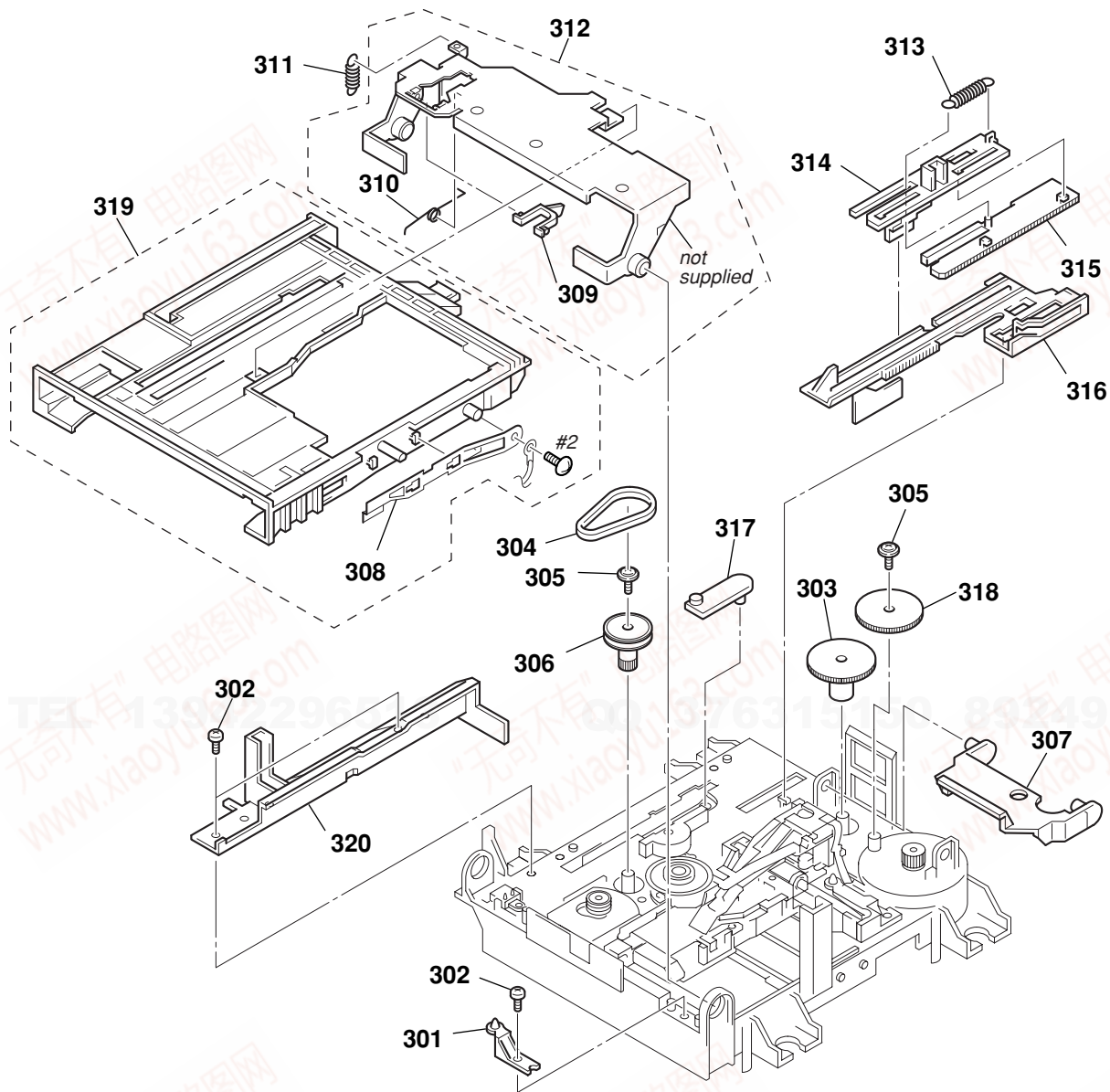

Ref. No.	Part No.	Description	Remarks	Ref. No.	Part No.	Description	Remarks
* 301	4-996-267-01	BASE (BU-D)		312	A-4680-638-B	RETAINER COMPLETE ASSY	
302	4-231-319-01	SCREW (2X6) CZN, +B (P) TRI		313	4-227-013-01	SPRING (EJ), TENSION	
303	4-227-007-01	GEAR (SB)		314	4-226-996-01	LIMITTER (EJ)	
304	4-227-025-01	BELT (LOADING)		315	4-226-995-01	SLIDER (EJ)	
305	3-372-761-01	SCREW (M1.7), TAPPING		316	4-226-997-04	SLIDER	
306	4-227-002-01	GEAR, PULLEY		317	4-226-998-01	LEVER (CHG)	
307	4-226-999-01	LEVER (HEAD)		318	4-227-006-01	GEAR (SA)	
308	X-4952-665-1	SPRING (SHT) ASSY, LEAF		319	A-4735-075-B	HOLDER ASSY	
309	A-468-063-8A	LOCK (HOLDER)		320	4-226-994-01	GUIDE (L)	
310	4-229-533-02	SPRING (STOPPER), TORSION		#2	7-685-850-04	SCREW +BVTT 2X3 (S)	
311	4-231-118-01	SPRING (HOLDER), TENSION					

7-4. MECHANISM SECTION-2
(MDM-7S1A)

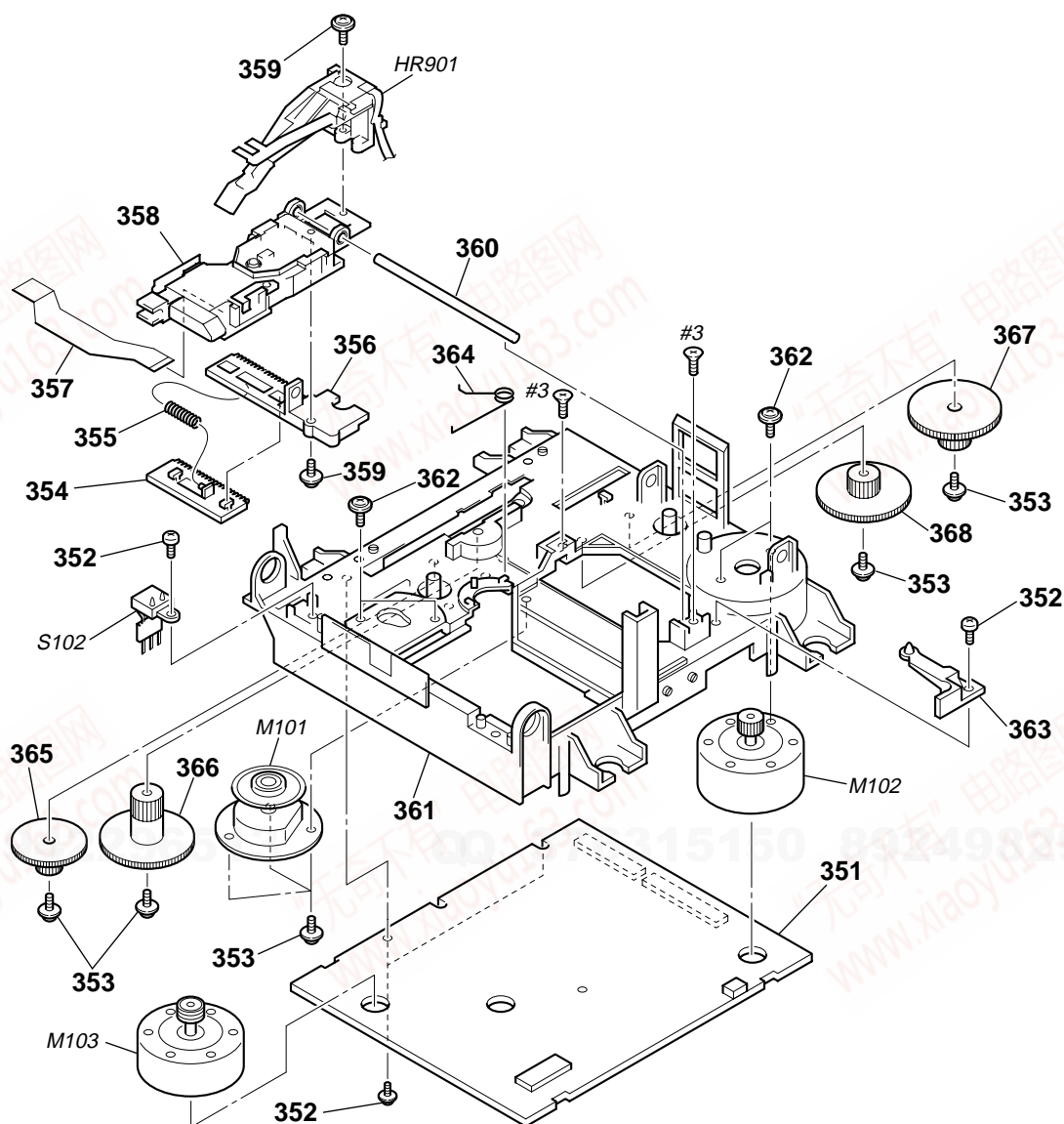

The components identified by mark Δ or dotted line with mark Δ are critical for safety. Replace only with part number specified.

Ref. No.	Part No.	Description	Remarks	Ref. No.	Part No.	Description	Remarks
351	A-4727-976-A	BD BOARD, COMPLETE		364	4-230-716-01	SPRING (SPDL), TORSION	
352	4-231-319-01	SCREW (2X6) CZN, +B (P) TRI		365	4-227-004-01	GEAR (LC)	
353	3-372-761-01	SCREW (M1.7), TAPPING		366	4-227-005-01	GEAR (LD)	
354	4-226-993-01	RACK		367	4-227-009-01	GEAR (SD)	
355	4-227-014-01	SPRING (RACK), COMPRESSION		368	4-227-008-01	GEAR (SC)	
356	4-226-992-01	BASE, SL		HR901	1-500-670-22	HEAD, OVER LIGHT	
357	1-678-514-11	PWB, FLEXIBLE		M101	A-4735-757-A	MOTOR ASSY, SPINDLE	
Δ 358	A-4672-541-A	OPTICAL PICK-UP KMS-260E		M102	A-4735-076-A	MOTOR ASSY, SLED	
359	4-988-560-01	SCREW (+P 1.7X6)		M103	A-4735-074-A	MOTOR ASSY, LOADING	
360	4-996-265-01	SHAFT, MAIN		S102	1-771-957-11	SWITCH, PUSH (2 KEY)	(REFLECT/PROTECT SW)
361	4-226-989-01	CHASSIS		#3	7-685-204-19	SCREW +KTP 2X6 TYPE2 NON-SLIT	
362	4-232-270-01	SCREW (1.7X3.5), +PWH					
363	4-226-990-04	BASE (BU-A)					

SECTION 8
ELECTRICAL PARTS LIST

NOTE:

- Due to standardization, replacements in the parts list may be different from the parts specified in the diagrams or the components used on the set.
- -XX, -X mean standardized parts, so they may have some difference from the original one.
- Items marked “*” are not stocked since they are seldom required for routine service. Some delay should be anticipated when ordering these items.
- CAPACITORS:
uF: μ F
- RESISTORS
All resistors are in ohms.
METAL: metal-film resistor
METAL OXIDE: Metal Oxide-film resistor
F: nonflammable

- COILS
uH: μ H
- SEMICONDUCTORS
In each case, u: μ , for example:
uA...: μ A... , uPA... , μ PA... ,
uPB... , μ PB... , uPC... , μ PC... ,
uPD... , μ PD...
• Abbreviation
RU : Russian model

When indicating parts by reference number, please include the board name.

The components identified by mark Δ or dotted line with mark Δ are critical for safety. Replace only with part number specified.

Ref. No.	Part No.	Description	Remarks	Ref. No.	Part No.	Description	Remarks
	A-4727-976-A	BD BOARD, COMPLETE *****		C242	1-164-156-11	CERAMIC CHIP 0.1uF	25V
		< CAPACITOR >		C250	1-164-156-11	CERAMIC CHIP 0.1uF	25V
C101	1-117-720-11	CERAMIC CHIP 4.7uF	10V	C251	1-164-156-11	CERAMIC CHIP 0.1uF	25V
C103	1-162-970-11	CERAMIC CHIP 0.01uF	10% 25V	C252	1-164-156-11	CERAMIC CHIP 0.1uF	25V
C104	1-164-156-11	CERAMIC CHIP 0.1uF	25V	C253	1-164-156-11	CERAMIC CHIP 0.1uF	25V
C105	1-135-259-11	TANTAL. CHIP 10uF	20% 6.3V	C254	1-162-970-11	CERAMIC CHIP 0.01uF	10% 25V
C106	1-135-259-11	TANTAL. CHIP 10uF	20% 6.3V	C255	1-164-156-11	CERAMIC CHIP 0.1uF	25V
C107	1-164-227-11	CERAMIC CHIP 0.022uF	10% 25V	C299	1-164-156-11	CERAMIC CHIP 0.1uF	25V
C108	1-164-156-11	CERAMIC CHIP 0.1uF	25V	C301	1-164-156-11	CERAMIC CHIP 0.1uF	25V
C109	1-165-176-11	CERAMIC CHIP 0.047uF	10% 16V	C302	1-164-156-11	CERAMIC CHIP 0.1uF	25V
C110	1-115-416-11	CERAMIC CHIP 0.001uF	5% 25V	C405	1-164-156-11	CERAMIC CHIP 0.1uF	25V
C111	1-162-970-11	CERAMIC CHIP 0.01uF	10% 25V	C406	1-162-970-11	CERAMIC CHIP 0.01uF	10% 25V
C112	1-164-227-11	CERAMIC CHIP 0.022uF	10% 25V	C407	1-164-156-11	CERAMIC CHIP 0.1uF	25V
C113	1-162-969-11	CERAMIC CHIP 0.0068uF	10% 25V	C409	1-164-156-11	CERAMIC CHIP 0.1uF	25V
C114	1-162-966-11	CERAMIC CHIP 0.0022uF	10% 50V	C410	1-126-206-11	ELECT CHIP 100uF	20% 6.3V
C115	1-164-156-11	CERAMIC CHIP 0.1uF	25V	C411	1-117-720-11	CERAMIC CHIP 4.7uF	10V
C116	1-117-720-11	CERAMIC CHIP 4.7uF	10V	C412	1-162-964-11	CERAMIC CHIP 0.001uF	10% 50V
C117	1-162-970-11	CERAMIC CHIP 0.01uF	10% 25V	C490	1-164-156-11	CERAMIC CHIP 0.1uF	25V
C118	1-162-968-11	CERAMIC CHIP 0.0047uF	10% 50V	C501	1-131-872-91	CERAMIC CHIP 1000PF	10% 630V
C119	1-125-837-91	CERAMIC CHIP 1uF	10% 6.3V	C502	1-164-156-11	CERAMIC CHIP 0.1uF	25V
C120	1-110-563-11	CERAMIC CHIP 0.068uF	10% 16V	C503	1-164-156-11	CERAMIC CHIP 0.1uF	25V
C121	1-162-970-11	CERAMIC CHIP 0.01uF	10% 25V	C504	1-117-370-11	CERAMIC CHIP 10uF	10V
C122	1-164-677-11	CERAMIC CHIP 0.033uF	10% 16V	C505	1-126-206-11	ELECT CHIP 100uF	20% 6.3V
C175	1-164-156-11	CERAMIC CHIP 0.1uF	25V	C550	1-117-970-11	ELECT CHIP 22uF	20% 10V
C194	1-164-156-11	CERAMIC CHIP 0.1uF	25V	C701	1-164-156-11	CERAMIC CHIP 0.1uF	25V
C205	1-162-968-11	CERAMIC CHIP 0.0047uF	10% 50V	C702	1-117-720-11	CERAMIC CHIP 4.7uF	10V
C206	1-126-206-11	ELECT CHIP 100uF	20% 6.3V	C703	1-164-156-11	CERAMIC CHIP 0.1uF	25V
C209	1-162-927-11	CERAMIC CHIP 100PF	5% 50V	C704	1-165-176-11	CERAMIC CHIP 0.047uF	10% 16V
C211	1-162-927-11	CERAMIC CHIP 100PF	5% 50V	C803	1-164-156-11	CERAMIC CHIP 0.1uF	25V
C212	1-162-927-11	CERAMIC CHIP 100PF	5% 50V	C809	1-117-720-11	CERAMIC CHIP 4.7uF	10V
C214	1-162-970-11	CERAMIC CHIP 0.01uF	10% 25V	C899	1-164-156-11	CERAMIC CHIP 0.1uF	25V
C215	1-164-677-11	CERAMIC CHIP 0.033uF	10% 16V	C901	1-126-206-11	ELECT CHIP 100uF	20% 6.3V
C216	1-125-889-91	CERAMIC CHIP 2.2uF	10% 10V	C902	1-164-156-11	CERAMIC CHIP 0.1uF	25V
C219	1-162-927-11	CERAMIC CHIP 100PF	5% 50V	C903	1-126-206-11	ELECT CHIP 100uF	20% 6.3V
C220	1-125-891-11	CERAMIC CHIP 0.47uF	10% 10V	C904	1-164-156-11	CERAMIC CHIP 0.1uF	25V
C221	1-162-970-11	CERAMIC CHIP 0.01uF	10% 25V	C905	1-126-206-11	ELECT CHIP 100uF	20% 6.3V
C230	1-164-156-11	CERAMIC CHIP 0.1uF	25V	C907	1-162-970-11	CERAMIC CHIP 0.01uF	10% 25V
C231	1-164-156-11	CERAMIC CHIP 0.1uF	25V	C908	1-117-370-11	CERAMIC CHIP 10uF	10V
C233	1-164-156-11	CERAMIC CHIP 0.1uF	25V	C909	1-104-852-11	TANTAL. CHIP 22uF	20% 10V
C234	1-164-156-11	CERAMIC CHIP 0.1uF	25V	C998	1-164-156-11	CERAMIC CHIP 0.1uF	25V
C235	1-164-156-11	CERAMIC CHIP 0.1uF	25V	C999	1-164-156-11	CERAMIC CHIP 0.1uF	25V
C240	1-164-156-11	CERAMIC CHIP 0.1uF	25V	C1102	1-164-156-11	CERAMIC CHIP 0.1uF	25V
C241	1-164-156-11	CERAMIC CHIP 0.1uF	25V			< CONNECTOR >	
				CN101	1-766-833-21	CONNECTOR, FFC/FPC (ZIF) 21P	

Ref. No.	Part No.	Description	Remarks	Ref. No.	Part No.	Description	Remarks
CN102	1-784-835-21	CONNECTOR,FFC(LIF(NON-ZIF))27P		R110	1-216-853-11	METAL CHIP 470K 5%	1/16W
CN103	1-784-834-21	CONNECTOR,FFC(LIF(NON-ZIF))23P		R111	1-216-833-11	METAL CHIP 10K 5%	1/16W
* CN104	1-580-055-21	PIN, CONNECTOR (SMD) 2P		R112	1-216-845-11	METAL CHIP 100K 5%	1/16W
CN105	1-784-859-21	CONNECTOR, FFC(LIF(NON-ZIF))7P		R113	1-216-833-11	METAL CHIP 10K 5%	1/16W
		< DIODE >		R114	1-216-829-11	METAL CHIP 4.7K 5%	1/16W
D101	8-719-988-61	DIODE 1SS355TE-17		R115	1-216-833-11	METAL CHIP 10K 5%	1/16W
D501	8-719-080-81	DIODE FS1J6		R116	1-216-827-11	METAL CHIP 3.3K 5%	1/16W
D502	8-719-080-81	DIODE FS1J6		R117	1-216-845-11	METAL CHIP 100K 5%	1/16W
		< IC >		R118	1-216-825-11	METAL CHIP 2.2K 5%	1/16W
IC101	8-752-080-95	IC CXA2523AR		R119	1-216-837-11	METAL CHIP 22K 5%	1/16W
IC153	8-759-671-27	IC MSM51V4400E-70TS-K		R120	1-216-839-11	METAL CHIP 33K 5%	1/16W
IC181	8-759-481-17	IC MC74ACT08DTR2		R121	1-216-825-11	METAL CHIP 2.2K 5%	1/16W
IC195	8-759-641-86	IC BR24C16F-E2		R122	1-216-833-11	METAL CHIP 10K 5%	1/16W
IC201	8-752-414-89	IC CXD2664R		R201	1-216-815-11	METAL CHIP 330 5%	1/16W
IC401	8-759-836-79	IC BH6519FS-E2		R202	1-216-819-11	METAL CHIP 680 5%	1/16W
IC701	8-759-473-51	IC TLV2361CDBV		R203	1-216-809-11	METAL CHIP 100 5%	1/16W
IC803	6-701-793-01	IC CY24115-2SCT		R205	1-216-833-11	METAL CHIP 10K 5%	1/16W
IC926	8-759-835-63	IC NJM2391DL1-26(Te1)		R206	1-216-833-11	METAL CHIP 10K 5%	1/16W
IC933	8-759-460-72	IC BA033FP-E2		R207	1-216-811-11	METAL CHIP 150 5%	1/16W
		< COIL >		R208	1-216-821-11	METAL CHIP 1K 5%	1/16W
L8	1-414-760-21	FERRITE 0uH		R209	1-216-815-11	METAL CHIP 330 5%	1/16W
L10	1-469-981-21	FERRITE 0uH		R210	1-216-839-11	METAL CHIP 33K 5%	1/16W
L122	1-414-760-21	FERRITE 0uH		R211	1-216-857-11	METAL CHIP 1M 5%	1/16W
L201	1-414-760-21	FERRITE 0uH		R212	1-216-851-11	METAL CHIP 330K 5%	1/16W
L202	1-469-981-21	FERRITE 0uH		R214	1-216-845-11	METAL CHIP 100K 5%	1/16W
L203	1-414-760-21	FERRITE 0uH		R216	1-216-864-11	METAL CHIP 0 5%	1/16W
L401	1-400-050-11	FERRITE 0uH		R217	1-216-833-11	METAL CHIP 10K 5%	1/16W
L402	1-400-050-11	FERRITE 0uH		R218	1-216-864-11	METAL CHIP 0 5%	1/16W
L501	1-400-050-11	FERRITE 0uH		R219	1-216-809-11	METAL CHIP 100 5%	1/16W
L502	1-400-050-11	FERRITE 0uH		R224	1-216-809-11	METAL CHIP 100 5%	1/16W
L550	1-414-760-21	FERRITE 0uH		R225	1-216-809-11	METAL CHIP 100 5%	1/16W
L601	1-469-981-21	FERRITE 0uH		R226	1-216-809-11	METAL CHIP 100 5%	1/16W
L602	1-469-981-21	FERRITE 0uH		R228	1-216-809-11	METAL CHIP 100 5%	1/16W
L603	1-414-760-21	FERRITE 0uH		R281	1-216-821-11	METAL CHIP 1K 5%	1/16W
L701	1-414-760-21	FERRITE 0uH		R298	1-216-809-11	METAL CHIP 100 5%	1/16W
L801	1-414-760-21	FERRITE 0uH		R299	1-216-864-11	METAL CHIP 0 5%	1/16W
* L899	1-500-282-11	FERRITE 0uH		R301	1-216-833-11	METAL CHIP 10K 5%	1/16W
		< TRANSISTOR >		R302	1-216-833-11	METAL CHIP 10K 5%	1/16W
Q181	8-729-018-75	TRANSISTOR 2SJ278MY		R303	1-216-833-11	METAL CHIP 10K 5%	1/16W
Q182	8-729-017-65	TRANSISTOR 2SK1764KY		R405	1-216-864-11	METAL CHIP 0 5%	1/16W
Q201	8-729-403-35	TRANSISTOR UN5113		R501	1-220-942-11	METAL CHIP 3.3 1%	1/4
Q202	8-729-101-07	TRANSISTOR 2SB798-DL		R502	1-220-942-11	METAL CHIP 3.3 1%	1/4
Q203	8-729-403-35	TRANSISTOR UN5113		R551	1-216-841-11	METAL CHIP 47K 5%	1/16W
Q701	8-729-402-93	TRANSISTOR UN5214		R552	1-216-841-11	METAL CHIP 47K 5%	1/16W
Q702	8-729-903-10	TRANSISTOR FMW1		R553	1-216-841-11	METAL CHIP 47K 5%	1/16W
Q703	8-729-402-93	TRANSISTOR UN5214		R701	1-216-821-11	METAL CHIP 1K 5%	1/16W
Q704	8-729-026-53	TRANSISTOR 2SA1576A-T106-QR		R702	1-216-821-11	METAL CHIP 1K 5%	1/16W
		< RESISTOR >		R703	1-216-821-11	METAL CHIP 1K 5%	1/16W
R101	1-216-298-00	METAL CHIP 2.2 5%	1/10W	R704	1-216-841-11	METAL CHIP 47K 5%	1/16W
R102	1-219-724-11	METAL CHIP 1 1%	1/4W	R705	1-216-833-11	METAL CHIP 10K 5%	1/16W
R103	1-216-829-11	METAL CHIP 4.7K 5%	1/16W	R706	1-218-855-11	METAL CHIP 2.2K 0.5%	1/10W
R104	1-216-853-11	METAL CHIP 470K 5%	1/16W	R707	1-218-863-11	METAL CHIP 4.7K 0.5%	1/10W
R105	1-216-863-11	RES-CHIP 3.3M 5%	1/10W	R708	1-218-863-11	METAL CHIP 4.7K 0.5%	1/10W
R106	1-216-845-11	METAL CHIP 100K 5%	1/16W	R709	1-218-855-11	METAL CHIP 2.2K 0.5%	1/10W
R107	1-216-819-11	METAL CHIP 680 5%	1/16W	R710	1-218-887-11	METAL CHIP 47K 0.5%	1/10W
R108	1-216-825-11	METAL CHIP 2.2K 5%	1/16W	R711	1-216-833-11	METAL CHIP 10K 5%	1/16W
R109	1-216-829-11	METAL CHIP 4.7K 5%	1/16W	R712	1-216-809-11	METAL CHIP 100 5%	1/16W
				R713	1-216-833-11	METAL CHIP 10K 5%	1/16W
				R802	1-216-864-11	METAL CHIP 0 5%	1/16W
				R803	1-216-864-11	METAL CHIP 0 5%	1/16W
				R805	1-216-809-11	METAL CHIP 100 5%	1/16W

MDS-JE480

BD DISPLAY KEY SW MAIN

Ref. No.	Part No.	Description	Quantity	Power	Remarks
R814	1-216-864-11	METAL CHIP	0	5%	1/16W
R815	1-216-864-11	METAL CHIP	0	5%	1/16W
< SWITCH >					
S101	1-762-596-21	SWITCH, PUSH (1 KEY) (LIMIT IN)			
S103	1-771-956-21	SWITCH, PUSH (1 KEY) (OUT)			
S104	1-771-955-21	SWITCH, PUSH (1 KEY) (PLAY)			
S105	1-771-955-21	SWITCH, PUSH (1 KEY) (REC)			

A-4727-955-A DISPLAY BOARD, COMPLETE *****					
4-212-590-22 HOLDER (FL)					
4-949-935-41 CUSHION (FL)					
< CAPACITOR >					
C709	1-107-826-11	CERAMIC CHIP	0.1uF	10%	16V
C760	1-107-826-11	CERAMIC CHIP	0.1uF	10%	16V
C761	1-162-964-11	CERAMIC CHIP	0.001uF	10%	50V
C762	1-162-964-11	CERAMIC CHIP	0.001uF	10%	50V
C763	1-162-964-11	CERAMIC CHIP	0.001uF	10%	50V
C764	1-107-826-11	CERAMIC CHIP	0.1uF	10%	16V
C765	1-126-153-11	ELECT	22uF	20%	6.3V
C766	1-131-992-91	CERAMIC CHIP	100000PF		35V
C767	1-162-964-11	CERAMIC CHIP	0.001uF	10%	50V
C769	1-162-923-11	CERAMIC CHIP	47PF	5%	50V
C781	1-124-584-00	ELECT	100uF	20%	10V
C782	1-162-970-11	CERAMIC CHIP	0.01uF	10%	25V
< CONNECTOR >					
CN701	1-779-552-21	CONNECTOR,FFC(LIF(NON-ZIF))15P			
CN710	1-785-712-11	CONNECTOR, BOARD TO BOARD 4P			
< DIODE >					
D775	8-719-046-39	DIODE SEL5821A-TP15 (MD LP)			
< FLUORESCENT INDICATOR TUBE >					
FL750	1-517-986-11	INDICATOR TUBE, FLUORESCENT			
< IC >					
IC760	6-702-067-01	IC PT6302-R-002			
IC781	8-759-826-33	IC NJL73H400A			
< TRANSISTOR >					
Q767	8-729-029-94	TRANSISTOR DTC143TSA			
Q775	8-729-900-80	TRANSISTOR DTC114ES			
< RESISTOR >					
R702	1-216-821-11	METAL CHIP	1K	5%	1/16W
R703	1-216-825-11	METAL CHIP	2.2K	5%	1/16W
R704	1-216-825-11	METAL CHIP	2.2K	5%	1/16W
R705	1-216-829-11	METAL CHIP	4.7K	5%	1/16W
R706	1-216-833-11	METAL CHIP	10K	5%	1/16W
R712	1-216-821-11	METAL CHIP	1K	5%	1/16W
R713	1-216-825-11	METAL CHIP	2.2K	5%	1/16W
R714	1-216-825-11	METAL CHIP	2.2K	5%	1/16W
R715	1-216-829-11	METAL CHIP	4.7K	5%	1/16W
R716	1-216-833-11	METAL CHIP	10K	5%	1/16W
R760	1-216-809-11	METAL CHIP	100	5%	1/16W
R761	1-216-809-11	METAL CHIP	100	5%	1/16W

Ref. No.	Part No.	Description	Quantity	Power	Remarks
R762	1-216-809-11	METAL CHIP	100	5%	1/16W
R763	1-216-809-11	METAL CHIP	100	5%	1/16W
R767	1-216-845-11	METAL CHIP	100K	5%	1/16W
R769	1-216-827-11	METAL CHIP	3.3K	5%	1/16W
R775	1-216-813-11	METAL CHIP	220	5%	1/16W
R781	1-216-805-11	METAL CHIP	47	5%	1/16W
R782	1-216-809-11	METAL CHIP	100	5%	1/16W
< SWITCH >					
S701	1-762-875-21	SWITCH, KEYBOARD (REC ●)			
S702	1-762-875-21	SWITCH, KEYBOARD (■)			
S703	1-762-875-21	SWITCH, KEYBOARD (▶▶)			
S704	1-762-875-21	SWITCH, KEYBOARD (◀◀)			
S705	1-762-875-21	SWITCH, KEYBOARD (■)			
S706	1-762-875-21	SWITCH, KEYBOARD (▷)			
S711	1-762-875-21	SWITCH, KEYBOARD (MENU/NO)			
S712	1-762-875-21	SWITCH, KEYBOARD (YES)			
S713	1-475-235-21	ENCODER, ROTARY (I-<<AMSD>>I)			
S714	1-762-875-21	SWITCH, KEYBOARD (CLEAR)			
S715	1-762-875-21	SWITCH, KEYBOARD (INPUT)			
S716	1-762-875-21	SWITCH, KEYBOARD (REC MODE)			
S721	1-762-875-21	SWITCH, KEYBOARD (EJECT ≡)			

1-683-587-11 KEY-SW BOARD *****					
< CAPACITOR >					
C740	1-107-826-11	CERAMIC CHIP	0.1uF	10%	16V
< CONNECTOR >					
CN720	1-785-713-11	CONNECTOR, BOARD TO BOARD 4P			
< DIODE >					
D726	8-719-046-44	DIODE SEL5221S (STNDBY)			
< TRANSISTOR >					
Q726	8-729-900-80	TRANSISTOR DTC114ES			
< RESISTOR >					
R722	1-216-821-11	METAL CHIP	1K	5%	1/16W
R723	1-216-825-11	METAL CHIP	2.2K	5%	1/16W
R724	1-216-825-11	METAL CHIP	2.2K	5%	1/16W
R725	1-216-829-11	METAL CHIP	4.7K	5%	1/16W
R726	1-216-864-11	METAL CHIP	0	5%	1/16W
R1726	1-216-813-11	METAL CHIP	220	5%	1/16W
< SWITCH >					
S722	1-762-875-21	SWITCH, KEYBOARD (PLAY MODE)			
S723	1-762-875-21	SWITCH, KEYBOARD (REPEAT)			
S724	1-762-875-21	SWITCH, KEYBOARD (LEVEL/DISPLAY/CHAR)			
S726	1-762-875-21	SWITCH, KEYBOARD (I/⊂)			

A-4727-954-A MAIN BOARD, COMPLETE *****					
7-685-646-79 SCREW +BVPT 3X8 TYPE2 TT(B)					
< LITHIUM BATTERY >					
BT406	1-756-121-11	BATTERY, LITHIUM SECONDARY			

Ref. No.	Part No.	Description	Remarks	Ref. No.	Part No.	Description	Remarks
< CAPACITOR >				C530	1-107-826-11	CERAMIC CHIP 0.1uF 10%	16V
C12	1-107-826-11	CERAMIC CHIP 0.1uF 10%	16V	C550	1-107-826-11	CERAMIC CHIP 0.1uF 10%	16V
C16	1-107-826-11	CERAMIC CHIP 0.1uF 10%	16V	C551	1-126-933-11	ELECT 100uF 20%	16V
C19	1-162-964-11	CERAMIC CHIP 0.001uF 10%	50V	C552	1-107-826-11	CERAMIC CHIP 0.1uF 10%	16V
C58	1-162-927-11	CERAMIC CHIP 100PF 5%	50V	C553	1-162-919-11	CERAMIC CHIP 22PF 5%	50V
C62	1-107-826-11	CERAMIC CHIP 0.1uF 10%	16V	C554	1-162-919-11	CERAMIC CHIP 22PF 5%	50V
C87	1-162-970-11	CERAMIC CHIP 0.01uF 10%	25V	C601	1-162-970-11	CERAMIC CHIP 0.01uF 10%	25V
C88	1-162-970-11	CERAMIC CHIP 0.01uF 10%	25V	C611	1-107-826-11	CERAMIC CHIP 0.1uF 10%	16V
C89	1-162-964-11	CERAMIC CHIP 0.001uF 10%	50V	C612	1-126-963-11	ELECT 4.7uF 20%	50V
C100	1-126-964-11	ELECT 10uF 20%	50V	C613	1-162-970-11	CERAMIC CHIP 0.01uF 10%	25V
C111	1-164-315-11	CERAMIC CHIP 470PF 5%	50V	C652	1-107-826-11	CERAMIC CHIP 0.1uF 10%	16V
C112	1-126-965-91	ELECT 22uF 20%	50V	C658	1-107-826-11	CERAMIC CHIP 0.1uF 10%	16V
C113	1-126-965-91	ELECT 22uF 20%	50V	C680	1-216-864-11	METAL CHIP 0 5%	1/16W
C160	1-126-965-91	ELECT 22uF 20%	50V	< CONNECTOR >			
C166	1-137-503-11	MYLAR 0.0001uF 5%	50V	CN1	1-784-417-11	CONNECTOR, FFC(LIF(NON-ZIF)23P	
C176	1-126-965-91	ELECT 22uF 20%	50V	CN2	1-779-295-11	CONNECTOR, FFC(LIF(NON-ZIF)27P	
C177	1-164-315-11	CERAMIC CHIP 470PF 5%	50V	* CN3	1-794-175-11	CONNECTOR, FFC(LIF(NON-ZIF)15P	
C211	1-164-315-11	CERAMIC CHIP 470PF 5%	50V	CN400	1-691-772-11	PLUG (MICRO CONNECTOR) 10P	
C212	1-126-965-91	ELECT 22uF 20%	50V	CN406	1-568-683-11	PIN, CONNECTOR (PC BAORD) 2P	
C213	1-126-965-91	ELECT 22uF 20%	50V	< DIODE >			
C266	1-137-503-11	MYLAR 0.0001uF 5%	50V	D111	8-719-988-61	DIODE 1SS355TE-17	
C270	1-126-965-91	ELECT 22uF 20%	50V	D112	8-719-988-61	DIODE 1SS355TE-17	
C276	1-126-965-91	ELECT 22uF 20%	50V	D211	8-719-988-61	DIODE 1SS355TE-17	
C277	1-164-315-11	CERAMIC CHIP 470PF 5%	50V	D212	8-719-988-61	DIODE 1SS355TE-17	
C312	1-107-826-11	CERAMIC CHIP 0.1uF 10%	16V	D381	8-719-988-61	DIODE 1SS355TE-17	
C317	1-107-826-11	CERAMIC CHIP 0.1uF 10%	16V	D382	8-719-988-61	DIODE 1SS355TE-17	
C362	1-107-826-11	CERAMIC CHIP 0.1uF 10%	16V	D401	8-719-085-36	DIODE 11EQS04-TB5	
C367	1-107-826-11	CERAMIC CHIP 0.1uF 10%	16V	D402	8-719-085-36	DIODE 11EQS04-TB5	
C401	1-126-939-11	ELECT 10000uF 20%	16V	D403	8-719-085-36	DIODE 11EQS04-TB5	
C402	1-107-826-11	CERAMIC CHIP 0.1uF 10%	16V	D404	8-719-085-36	DIODE 11EQS04-TB5	
C404	1-126-933-11	ELECT 100uF 20%	16V	D406	8-719-988-61	DIODE 1SS355TE-17	
C405	1-162-970-11	CERAMIC CHIP 0.01uF 10%	25V	D408	8-719-085-36	DIODE 11EQS04-TB5	
C406	1-124-252-00	ELECT 0.33uF 20%	50V	D409	8-719-085-36	DIODE 11EQS04-TB5	
C411	1-126-939-11	ELECT 10000uF 20%	16V	D409	8-719-085-36	DIODE 11EQS04-TB5	
C412	1-107-826-11	CERAMIC CHIP 0.1uF 10%	16V	D411	8-719-200-82	DIODE 11ES2	
C413	1-107-826-11	CERAMIC CHIP 0.1uF 10%	16V	D412	8-719-200-82	DIODE 11ES2	
C416	1-126-916-11	ELECT 1000uF 20%	6.3V	D421	8-719-200-82	DIODE 11ES2	
C423	1-128-576-11	ELECT 100uF 20%	63V	D422	8-719-976-96	DIODE DTZ4.7C	
C424	1-126-964-11	ELECT 10uF 20%	50V	D423	8-719-977-81	DIODE DTZ33B	
C425	1-126-968-11	ELECT 100uF 20%	50V	D431	8-719-988-61	DIODE 1SS355TE-17	
C426	1-126-965-91	ELECT 22uF 20%	50V	D432	8-719-988-61	DIODE 1SS355TE-17	
C431	1-104-663-11	ELECT 33uF 20%	25V	D433	8-719-988-61	DIODE 1SS355TE-17	
C432	1-126-965-91	ELECT 22uF 20%	50V	D461	8-719-200-82	DIODE 11ES2	
C441	1-126-933-11	ELECT 100uF 20%	16V	D462	8-719-200-82	DIODE 11ES2	
C442	1-162-970-11	CERAMIC CHIP 0.01uF 10%	25V	D466	8-719-200-82	DIODE 11ES2	
C443	1-107-826-11	CERAMIC CHIP 0.1uF 10%	16V	D467	8-719-200-82	DIODE 11ES2	
C461	1-126-935-11	ELECT 470uF 20%	16V	< FERRITE BEAD >			
C466	1-126-935-11	ELECT 470uF 20%	16V	FB166	1-216-864-11	METAL CHIP 0 5%	1/16W
C491	1-126-935-11	ELECT 470uF 20%	16V	FB410	1-216-864-11	METAL CHIP 0 5%	1/16W
C492	1-107-826-11	CERAMIC CHIP 0.1uF 10%	16V	FB460	1-414-813-11	FERRITE 0UH	
C493	1-107-826-11	CERAMIC CHIP 0.1uF 10%	16V	FB465	1-414-813-11	FERRITE 0UH	
C500	1-126-934-11	ELECT 220uF 20%	10V	< IC >			
C501	1-107-826-11	CERAMIC CHIP 0.1uF 10%	16V	IC1	6-801-321-01	IC M30622MGN-373FP	
C502	1-162-966-11	CERAMIC CHIP 0.0022uF 10%	50V	IC310	8-759-710-97	IC NJM4565M(TE2)	
C503	1-162-966-11	CERAMIC CHIP 0.0022uF 10%	50V	IC360	8-759-710-97	IC NJM4565M(TE2)	
C504	1-126-933-11	ELECT 100uF 20%	16V	IC401	8-759-647-10	IC uPC2933HF	
C505	1-107-826-11	CERAMIC CHIP 0.1uF 10%	16V	IC406	8-759-481-02	IC M62016L	
C509	1-216-864-11	METAL CHIP 0 5%	1/16W	IC411	8-759-231-53	IC M5F7805L	
C519	1-162-964-11	CERAMIC CHIP 0.001uF 10%	50V	IC440	8-759-822-09	IC LB1641	
C523	1-126-933-11	ELECT 100uF 20%	16V				
C524	1-107-826-11	CERAMIC CHIP 0.1uF 10%	16V				

MDS-JE480

MAIN

Ref. No.	Part No.	Description	Remarks	Ref. No.	Part No.	Description	Remarks
IC490	8-759-647-10	IC uPC2933HF		R97	1-216-833-11	METAL CHIP 10K	5% 1/16W
IC500	6-700-563-01	IC AK4552VT-E2		R100	1-216-845-11	METAL CHIP 100K	5% 1/16W
IC550	8-759-242-70	IC TC7WU04F(TE12R)		R111	1-216-839-11	METAL CHIP 33K	5% 1/16W
				R112	1-216-833-11	METAL CHIP 10K	5% 1/16W
IC600	8-759-269-92	IC SN74HCU04ANSR		R113	1-216-849-11	METAL CHIP 220K	5% 1/16W
IC611	8-749-019-26	IC TORX141 (DIGITAL OPTICAL IN)		R115	1-216-805-11	METAL CHIP 47	5% 1/16W
		< JACK >		R163	1-216-845-11	METAL CHIP 100K	5% 1/16W
J300	1-784-429-11	JACK, PIN 4P (ANALOG IN/OUT)		R164	1-216-809-11	METAL CHIP 100	5% 1/16W
		< COIL >		R165	1-216-829-11	METAL CHIP 4.7K	5% 1/16W
L349	1-216-864-11	METAL CHIP 0	5% 1/16W	R166	1-216-833-11	METAL CHIP 10K	5% 1/16W
L450	1-216-864-11	METAL CHIP 0	5% 1/16W	R171	1-216-819-11	METAL CHIP 680	5% 1/16W
L451	1-216-864-11	METAL CHIP 0	5% 1/16W	R177	1-216-845-11	METAL CHIP 100K	5% 1/16W
L506	1-216-864-11	METAL CHIP 0	5% 1/16W	R178	1-216-815-11	METAL CHIP 330	5% 1/16W
L523	1-216-864-11	METAL CHIP 0	5% 1/16W	R181	1-216-829-11	METAL CHIP 4.7K	5% 1/16W
L524	1-216-864-11	METAL CHIP 0	5% 1/16W	R211	1-216-839-11	METAL CHIP 33K	5% 1/16W
L551	1-216-864-11	METAL CHIP 0	5% 1/16W	R212	1-216-833-11	METAL CHIP 10K	5% 1/16W
L552	1-216-864-11	METAL CHIP 0	5% 1/16W	R213	1-216-849-11	METAL CHIP 220K	5% 1/16W
L651	1-216-864-11	METAL CHIP 0	5% 1/16W	R215	1-216-805-11	METAL CHIP 47	5% 1/16W
L653	1-216-864-11	METAL CHIP 0	5% 1/16W	R263	1-216-845-11	METAL CHIP 100K	5% 1/16W
L657	1-216-864-11	METAL CHIP 0	5% 1/16W	R264	1-216-809-11	METAL CHIP 100	5% 1/16W
L658	1-216-864-11	METAL CHIP 0	5% 1/16W	R265	1-216-829-11	METAL CHIP 4.7K	5% 1/16W
L660	1-216-864-11	METAL CHIP 0	5% 1/16W	R266	1-216-833-11	METAL CHIP 10K	5% 1/16W
L662	1-216-864-11	METAL CHIP 0	5% 1/16W	R271	1-216-819-11	METAL CHIP 680	5% 1/16W
L666	1-216-864-11	METAL CHIP 0	5% 1/16W	R277	1-216-845-11	METAL CHIP 100K	5% 1/16W
L668	1-216-864-11	METAL CHIP 0	5% 1/16W	R278	1-216-815-11	METAL CHIP 330	5% 1/16W
		< TRANSISTOR >		R281	1-216-829-11	METAL CHIP 4.7K	5% 1/16W
Q181	8-729-823-22	TRANSISTOR 2SC3576		R380	1-216-845-11	METAL CHIP 100K	5% 1/16W
Q281	8-729-823-22	TRANSISTOR 2SC3576		R381	1-216-847-11	METAL CHIP 150K	5% 1/16W
Q380	8-729-422-57	TRANSISTOR UN4111		R406	1-216-813-11	METAL CHIP 220	5% 1/16W
Q421	8-729-209-60	TRANSISTOR 2SB1375		R407	1-216-833-11	METAL CHIP 10K	5% 1/16W
Q440	8-729-900-80	TRANSISTOR DTC114ES		R420	1-216-864-11	METAL CHIP 0	5% 1/16W
Q445	8-729-119-76	TRANSISTOR 2SA1175-HFE		R421	1-216-829-11	METAL CHIP 4.7K	5% 1/16W
Q911	8-729-922-37	TRANSISTOR 2SD2144S-UVW		R423	1-216-845-11	METAL CHIP 100K	5% 1/16W
		< RESISTOR >		R424	1-216-813-11	METAL CHIP 220	5% 1/16W
R4	1-216-864-11	METAL CHIP 0	5% 1/16W	R425	1-216-813-11	METAL CHIP 220	5% 1/16W
R9	1-216-829-11	METAL CHIP 4.7K	5% 1/16W	R430	1-216-833-11	METAL CHIP 10K	5% 1/16W
R17	1-216-864-11	METAL CHIP 0	5% 1/16W	R431	1-216-809-11	METAL CHIP 100	5% 1/16W
R31	1-216-864-11	METAL CHIP 0	5% 1/16W	R432	1-216-819-11	METAL CHIP 680	5% 1/16W
R33	1-216-864-11	METAL CHIP 0	5% 1/16W	R433	1-216-815-11	METAL CHIP 330	5% 1/16W
R41	1-216-845-11	METAL CHIP 100K	5% 1/16W	R434	1-216-837-11	METAL CHIP 22K	5% 1/16W
R44	1-216-833-11	METAL CHIP 10K	5% 1/16W	R435	1-216-833-11	METAL CHIP 10K	5% 1/16W
R46	1-216-833-11	METAL CHIP 10K	5% 1/16W	R436	1-216-841-11	METAL CHIP 47K	5% 1/16W
R49	1-216-833-11	METAL CHIP 10K	5% 1/16W	R437	1-216-821-11	METAL CHIP 1K	5% 1/16W
R50	1-216-864-11	METAL CHIP 0	5% 1/16W	R441	1-216-837-11	METAL CHIP 22K	5% 1/16W
R51	1-216-833-11	METAL CHIP 10K	5% 1/16W	R442	1-216-835-11	METAL CHIP 15K	5% 1/16W
R53	1-216-833-11	METAL CHIP 10K	5% 1/16W	R443	1-216-837-11	METAL CHIP 22K	5% 1/16W
R55	1-216-833-11	METAL CHIP 10K	5% 1/16W	R511	1-216-864-11	METAL CHIP 0	5% 1/16W
R61	1-216-833-11	METAL CHIP 10K	5% 1/16W	R512	1-216-864-11	METAL CHIP 0	5% 1/16W
R62	1-216-809-11	METAL CHIP 100	5% 1/16W	R513	1-216-864-11	METAL CHIP 0	5% 1/16W
R87	1-216-833-11	METAL CHIP 10K	5% 1/16W	R514	1-216-864-11	METAL CHIP 0	5% 1/16W
R88	1-216-833-11	METAL CHIP 10K	5% 1/16W	R551	1-216-857-11	METAL CHIP 1M	5% 1/16W
R90	1-216-845-11	METAL CHIP 100K	5% 1/16W	R552	1-216-815-11	METAL CHIP 330	5% 1/16W
R93	1-216-833-11	METAL CHIP 10K	5% 1/16W	R554	1-216-817-11	METAL CHIP 470	5% 1/16W
R94	1-216-833-11	METAL CHIP 10K	5% 1/16W	R556	1-216-817-11	METAL CHIP 470	5% 1/16W
R95	1-216-833-11	METAL CHIP 10K	5% 1/16W	R614	1-216-841-11	METAL CHIP 47K	5% 1/16W
				R623	1-216-864-11	METAL CHIP 0	5% 1/16W
				R911	1-216-825-11	METAL CHIP 2.2K	5% 1/16W
				R912	1-216-841-11	METAL CHIP 47K	5% 1/16W
				R943	1-216-821-11	METAL CHIP 1K	5% 1/16W
				R1091	1-216-833-11	METAL CHIP 10K	5% 1/16W

Ref. No.	Part No.	Description	Remarks	Ref. No.	Part No.	Description	Remarks
		< VIBRATOR >				ACCESSORIES *****	
X15	1-795-004-21	VIBRATOR, CERAMIC (10MHz)		1-476-723-11	REMOTE COMMANDER (RM-D10E)		
X550	1-767-406-21	VIBRATOR, CRYSTAL (11.2896MHz)		1-776-263-12	CORD, CONNECTION (AUDIO)		

	1-683-584-11	PT BOARD *****		1-574-264-11	CORD, LIGHT PLUG (OPTICAL)		
		< CAPACITOR >		4-238-553-12	INSTRUCTION MANUAL (ENGLISH) (EXCEPT RU)		
△ C910	1-113-920-11	CERAMIC 0.0022uF 20% 250V		4-238-553-21	INSTRUCTION MANUAL (FRENCH,DUTCH,SWEDISH,GERMAN,SPANISH, ITALIAN,POLISH)(AEP)		
C923	1-131-992-91	CERAMIC CHIP 100000PF 35V		4-238-553-31	INSTRUCTION MANUAL (DANISH,FINNISH) (AEP)		
C924	1-131-992-91	CERAMIC CHIP 100000PF 35V		4-238-553-41	INSTRUCTION MANUAL (PORTUGUESE)(AEP)		
C951	1-131-992-91	CERAMIC CHIP 100000PF 35V		4-238-553-51	INSTRUCTION MANUAL (RUSSIAN)(AEP)		
C952	1-131-992-91	CERAMIC CHIP 100000PF 35V		4-238-553-61	INSTRUCTION MANUAL (RUSSIAN)(RU)		
		< CONNECTOR >		4-981-643-11	COVER, BATTERY (For RM-D10E)		
* CN900	1-580-230-11	PIN, CONNECTOR (PC BOARD) 2P		The components identified by mark △ or dotted line with mark △ are critical for safety. Replace only with part number specified.			
		< DIODE >					
D910	8-719-988-61	DIODE 1SS355TE-17					
		< LINE FILTER >					
△ LF900	1-419-625-11	COIL, LINE FILTER					
		< RELAY >					
△ RY910	1-755-356-11	RELAY					
		< TRANSFORMER >					
△ TR950	1-437-335-11	TRANSFORMER, POWER (US)					
△ TR950	1-437-336-11	TRANSFORMER, POWER (AEP, UK, RU)					

		MISCELLANEOUS *****					
△ 9	1-770-019-51	ADAPTOR, CONVERSION PLUG (UK)					
△ 12	1-792-811-11	WIRE (FLAT TYPE) (23 CORE)					
△ 12	1-777-071-63	CORD, POWER (AEP, UK, RU)					
* 14	1-783-532-32	CORD, POWER (US)					
	1-569-972-21	SOCKET, SHORT 2P					
55	1-757-929-11	WIRE (FLAT TYPE) (15 CORE)					
357	1-678-514-11	PWB, FLEXIBLE					
△ 358	A-4672-541-A	OPTICAL PICK-UP KMS-260E					
HR901	1-500-670-22	HEAD, OVER LIGHT					
M101	A-4735-757-A	MOTOR ASSY, SPINDLE					
M102	A-4735-076-A	MOTOR ASSY, SLED					
M103	A-4735-074-A	MOTOR ASSY, LOADING					
S102	1-771-957-11	SWITCH, PUSH (2 KEY) (REFLECT/PROTECT SW)					
△ TR900	1-435-543-11	TRANSFORMER, POWER (US)					
△ TR900	1-435-544-11	TRANSFORMER, POWER (AEP, UK, RU)					
